 **PARTS
CATALOGUE**

YP180E'04 (5XM3)
MAJESTY (EU2) EUROPE

YAMAHA
GENUINE
Parts & Accessories

2C5XM - 300E1

YP180E (5XM3) MAJESTY
PARTS CATALOGUE

©2003 by Yamaha Motor España S.A.
1st Edition, December 2003
All rights reserved.

Any reprinting or unauthorized use
without the written permission of
Yamaha Motor España S.A.
is expressly prohibited.



CRISTAL



DARK GRAY METALLIC, 8



FINE SILVER

FOREWORD

This Parts Catalogue is related to the parts for the model(s) in the below frame. When you are ordering replacement parts, please refer to this Parts Catalogue and quote both part numbers and part names correctly.

YP180E“MAJESTY”(5XM3)

1. Modifications or additions which have been after issue of the Parts Catalogue will be announced in the Yamaha Parts News. It is advisable that you make necessary corrections to the Parts Catalogue according to the Yamaha Parts News.
2. Abbreviations
The following abbreviations are used in this Parts Catalogue:
 “UR” Use specified parts number
 “UN” Use as many as needed
 “AP” Alternate Parts
 “LM” Local Made (Parts need to be ordered locally)
 “F#” Frame No. (Applicable machine No.)
3. Parts which are to be supplied in an assembly, are listed with a dot (•) in front of the part name as shown below.

EXAMPLE

CARBURETOR ASSY

- JET, pilot
- NOZZLE, main

4. Number of component for assembly.
The numeral appearing to the right of each component part indicates the quantity of parts for each assembly unit.

EXAMPLE

PART No.	DESCRIPTION	Q'TY.	REMARKS
2F5-83310-60	FRONT FLASHER LIGHT, ASSY	2	
115-83311-60	• BULB, (6V-18W)	1	

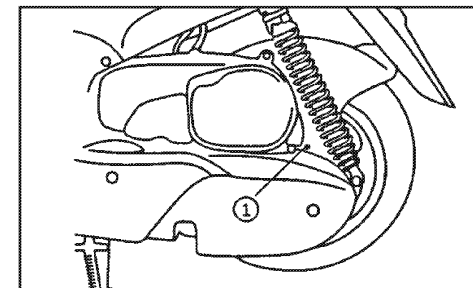
5. Applicable colors of graphics are represented in the “REMARKS” as shown below.

EXAMPLE

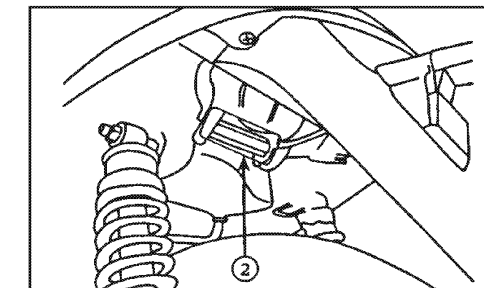
PART No.	DESCRIPTION	Q'TY	REMARKS
2N4-24110-00-X5	FUEL TANK COMP.	1	MAXIM RED
3J1-24240-10	• GRAFIC, FUEL TANK	1	for MXR

6. Applicable Serial No. and Color code

① Engine Serial No.



② Frame Serial No.



7. Note that the illustrations are for reference in finding parts numbers, not to be used for assembling. When assembling, please use the applicable service manual.
8. The asterisk (*) before a reference number indicates modification items after the first edition.

MODEL LABEL

1. A label called "Model Label" is affixed in the location as indicated in (3) below. When using this parts catalogue, please be sure to cross refer the "Model code-Production code No." in the catalogue to the "Model code-production code No." indicated on the Model Label affixed onto the product concerned.

2. "Model Label" Indication

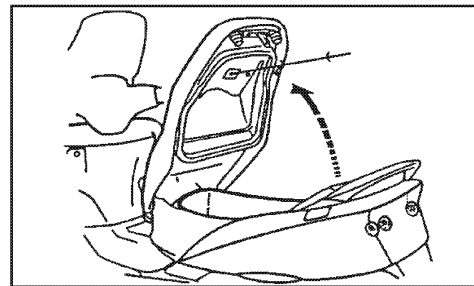


① Model Type Code

② Production Code No.

③ Colouring Type

3. Model Label Affixing Location



4. Model Code-Production Code Number of Model Listed in This Parts Catalog.

Model Code	Production Code No.	Country (destination)	Model Code	Production Code No.	Country (destination)
5XM3	010	ITALY			
	080	SLOVENIA			
		HUNGARI			
		ISRAEL			
		TURKEY			
		FINLAND			

5. Colouring information.

Model code	Colouring type code	Colour code	Colour Name	Abb.
5XM3	A	0316	CRISTAL	CST
	B	0809	DARK GRAY METALLIC, 8	DNM8
	C	00LK	FINE SILVER	FIS

CONTENTS

CYLINDER HEAD	B2	HEADLIGHT	E2
CRANKSHAFT & PISTON	B3	TAILLIGHT	E3
VALVE	B4	HANDLE SWITCH & LEVER	E5
CAMSHAFT & CHAIN	B5	ELECTRICAL 1	E6
WATER PUMP	B6	ELECTRICAL 2	E7
RADIATOR & HOSE	B7		
OIL PUMP	B8		
INTAKE	B9		
CARBURETOR	B10		
EXHAUST	B12		
CRANKCASE	B14		
CRANKCASE COVER 1	B15		
STARTER	C3		
CLUTCH	C4		
TRANSMISSION	C6		
FRAME	C7		
FENDER	C8		
SIDE COVER	C9		
REAR ARM & SUSPENSION	C11		
FRONT FORK	C12		
FUEL TANK	C14		
SEAT	C15		
FRONT WHEEL	D3		
FRONT BRAKE CALIPER	D4		
REAR WHEEL	D5		
REAR BRAKE CALIPER	D6		
STEERING HANDLE & CABLE	D7		
FRONT MASTER CYLINDER	D8		
STAND & FOOTREST	D9		
COWLING 1	D10		
GENERATOR	D12		
STARTING MOTOR	D13		
FLASHER LIGHT	D14		
METER	D15		
		NUMERICAL INDEX	M1

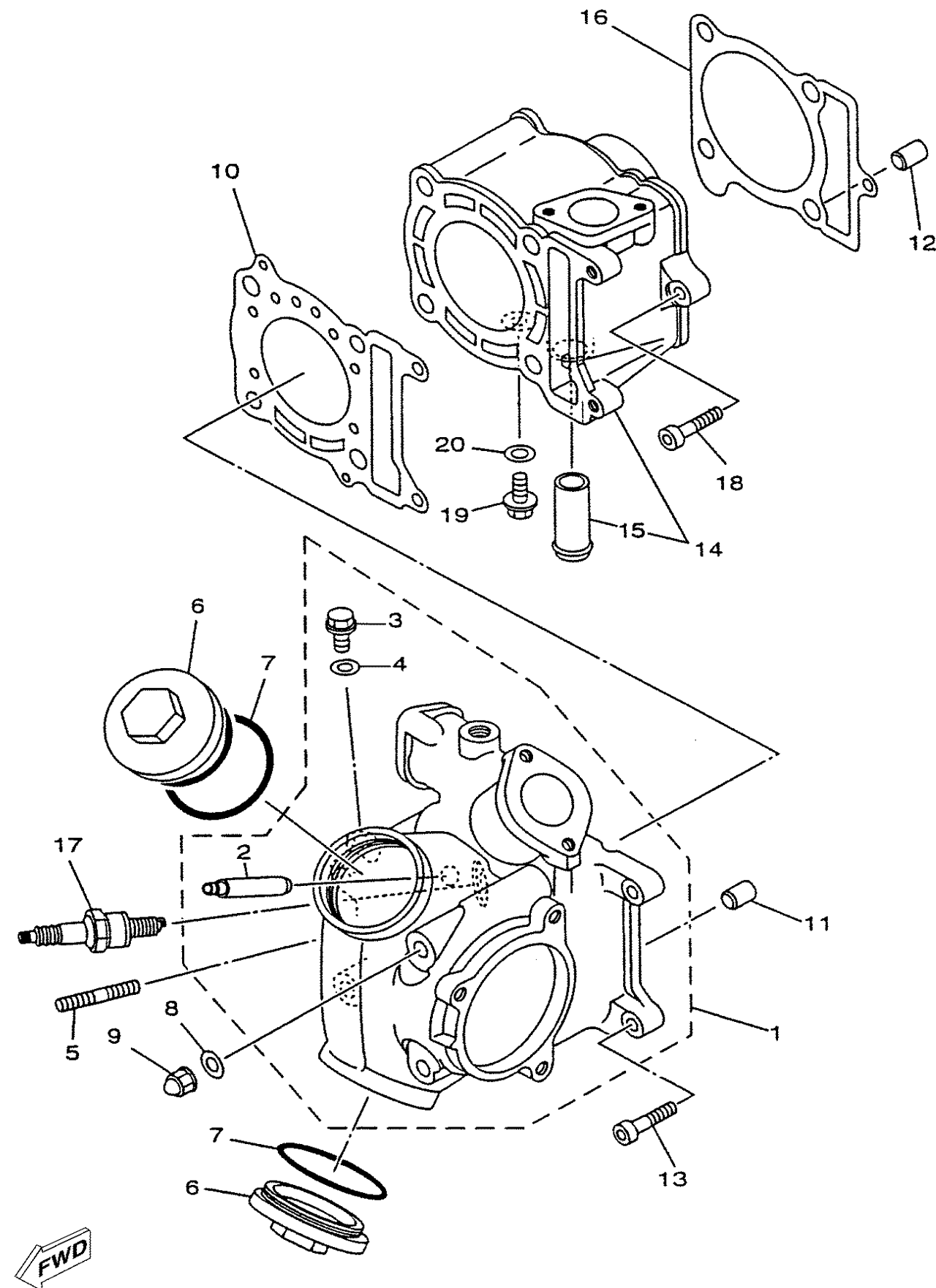


FIG. 1 CYLINDER HEAD

REF. NO.	PART NO.	DESCRIPTION	5XM3				REMARKS
1	5XM-E1111-00	HEAD, CYLINDER 1	1				
2	3UH-11133-01	.GUIDE, VALVE 1	2				
3	90105-06X04	.BOLT, FLANGE	1				
4	90201-06X09	.WASHER, PLATE	1				
5	95617-08620	BOLT, STUD	2				
6	5DS-E1186-00	COVER, CYLINDER HEAD SIDE 2	2				
7	93210-44X00	O-RING	2				
8	90201-08609	WASHER, PLATE	4				
9	90176-08026	NUT, CROWN	4				
10	5XM-E1181-00	GASKET, CYLINDER HEAD 1	1				
11	99530-10114	PIN, DOWEL	2				
12	99530-10114	PIN, DOWEL	2				
13	90110-06X04	BOLT, HEXAGON SOCKET HEAD	2				
14	5XM-E1311-00	CYLINDER 1	1				
15	11H-12469-00	JOINT 1	1				
16	5XM-E1351-00	GASKET, CYLINDER	1				
17	94701-00X00	PLUG, SPARK (NGK BR9ES)	1				
18	90110-06X04	BOLT, HEXAGON SOCKET HEAD	1				
19	90105-06X04	BOLT, FLANGE	1				
20	90430-06014	GASKET	1				

5XL3300-C010

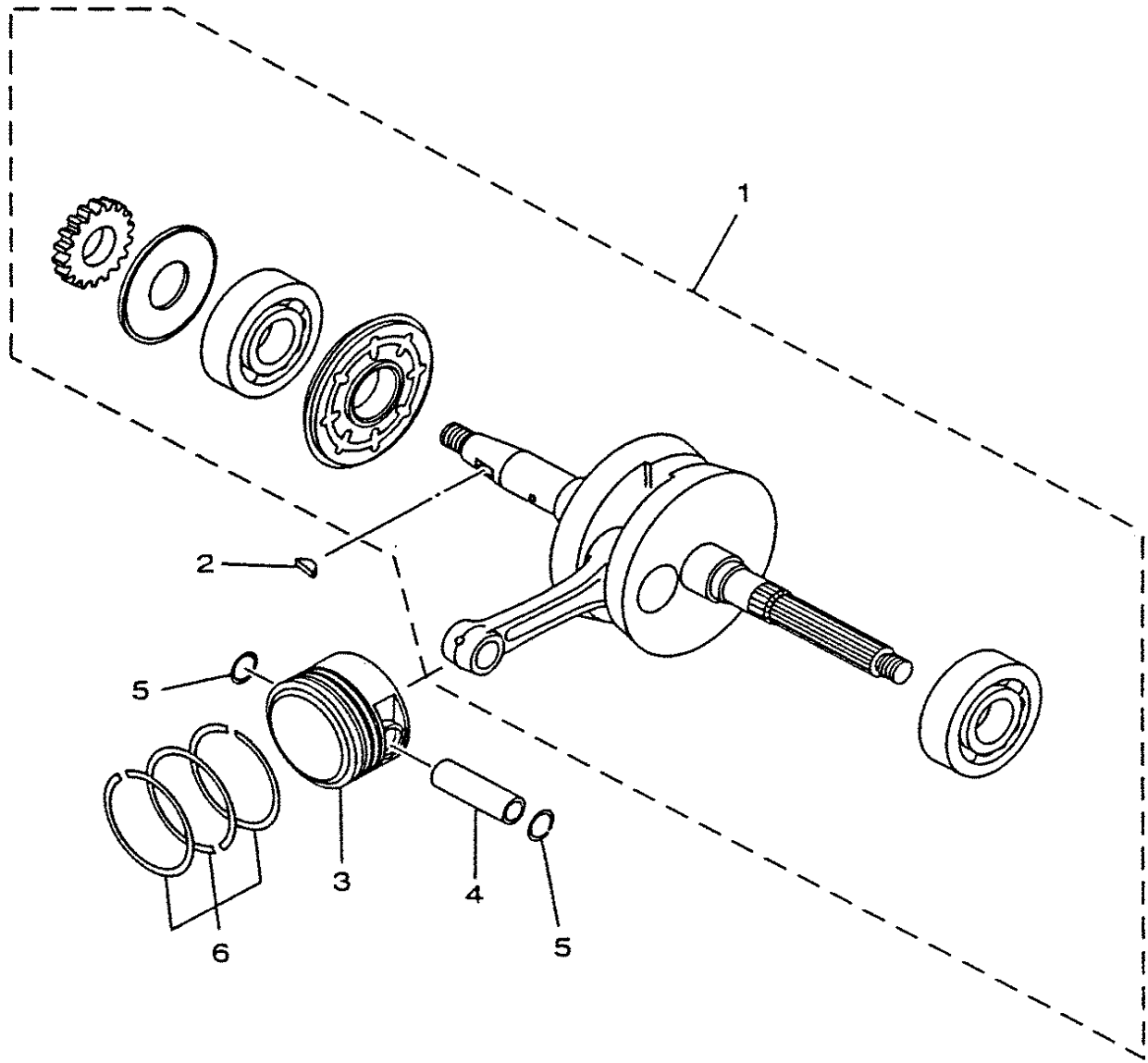


FIG. 2 CRANKSHAFT & PISTON

REF. NO.	PART NO.	DESCRIPTION	5XM3				REMARKS
1	5XM-E1400-00	CRANKSHAFT ASSY	1				
2	90280-03045	KEY, WOODRUFF	1				
3	5XM-E1631-00	PISTON (STD)	1				UR STD
	5XM-E1635-00	PISTON (0.25MM O/S)	1				AP
	5XM-E1636-00	PISTON (0.50MM O/S)	1				AP
4	5XM-E1633-00	PIN, PISTON	1				
5	93450-16X01	CIRCLIP	2				
6	5XM-E1603-00	PISTON RING SET (STD)	1				UR STD
	5XM-E1604-00	PISTON RING SET (0.25MM O/S)	1				AP
	5XM-E1605-00	PISTON RING SET (0.50MM O/S)	1				AP



5XL3300-C020

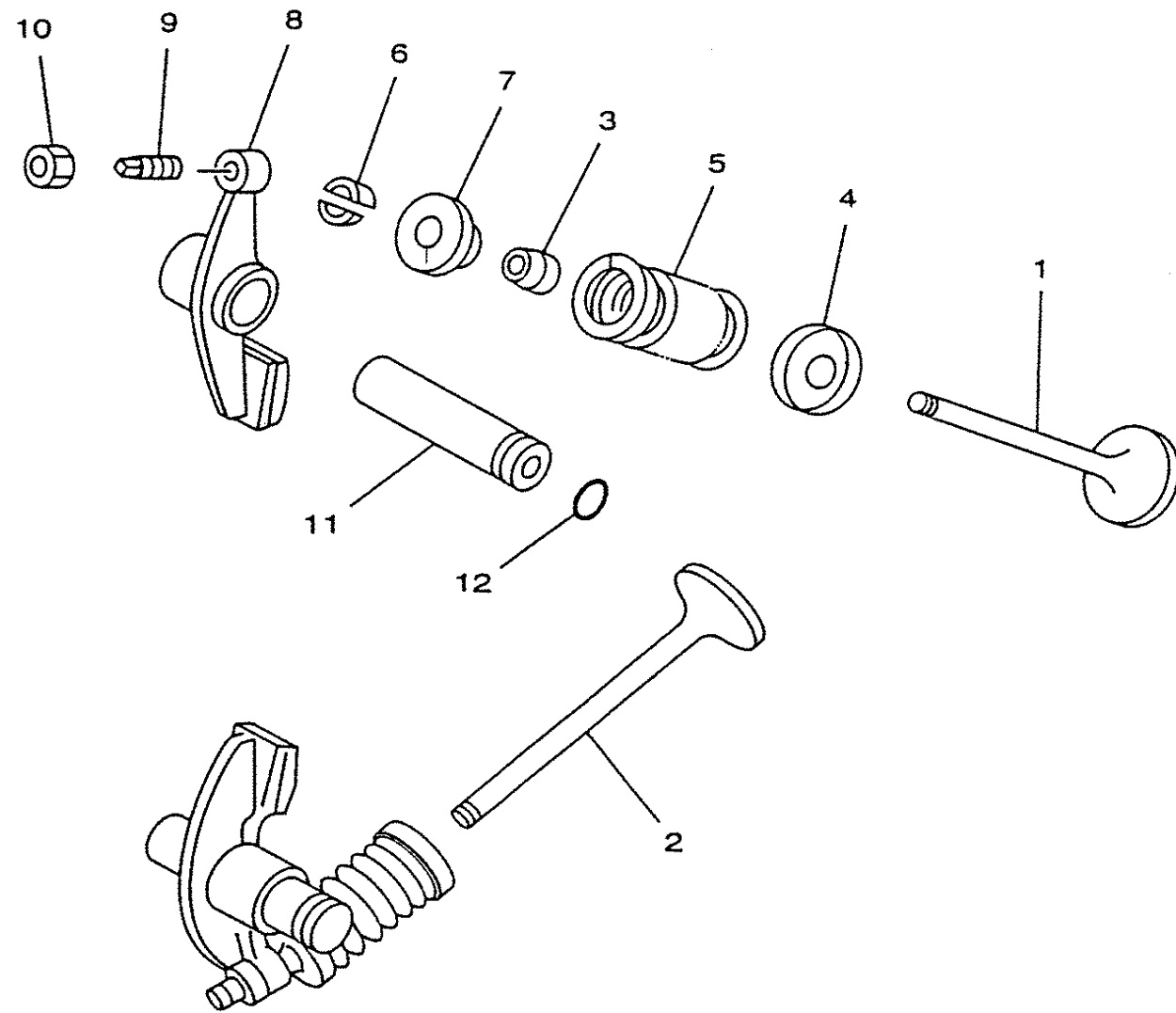


FIG. 3 VALVE

REF. NO.	PART NO.	DESCRIPTION	5XM3				REMARKS
1	5XM-12111-00	VALVE, INTAKE	1				
2	5XM-12121-00	VALVE, EXHAUST	1				
3	4TE-12119-00	SEAL, VALVE STEM	2				
4	1WG-12116-00	SEAT, VALVE SPRING	2				
5	1WG-12113-01	SPRING, VALVE INNER	2				PINK
6	1WG-12118-00	COTTER, VALVE	4				
7	3UH-12117-00	RETAINER, VALVE SPRING	2				
8	3UH-12151-00	ARM, VALVE ROCKER	2				
9	22F-12159-00	SCREW, VALVE ADJUSTING	2				
10	90170-05302	NUT	2				
11	5DS-E2156-00	SHAFT, ROCKER 2	2				
12	93210-09729	O-RING	2				



5RN8300-1030



5XL1300-A040

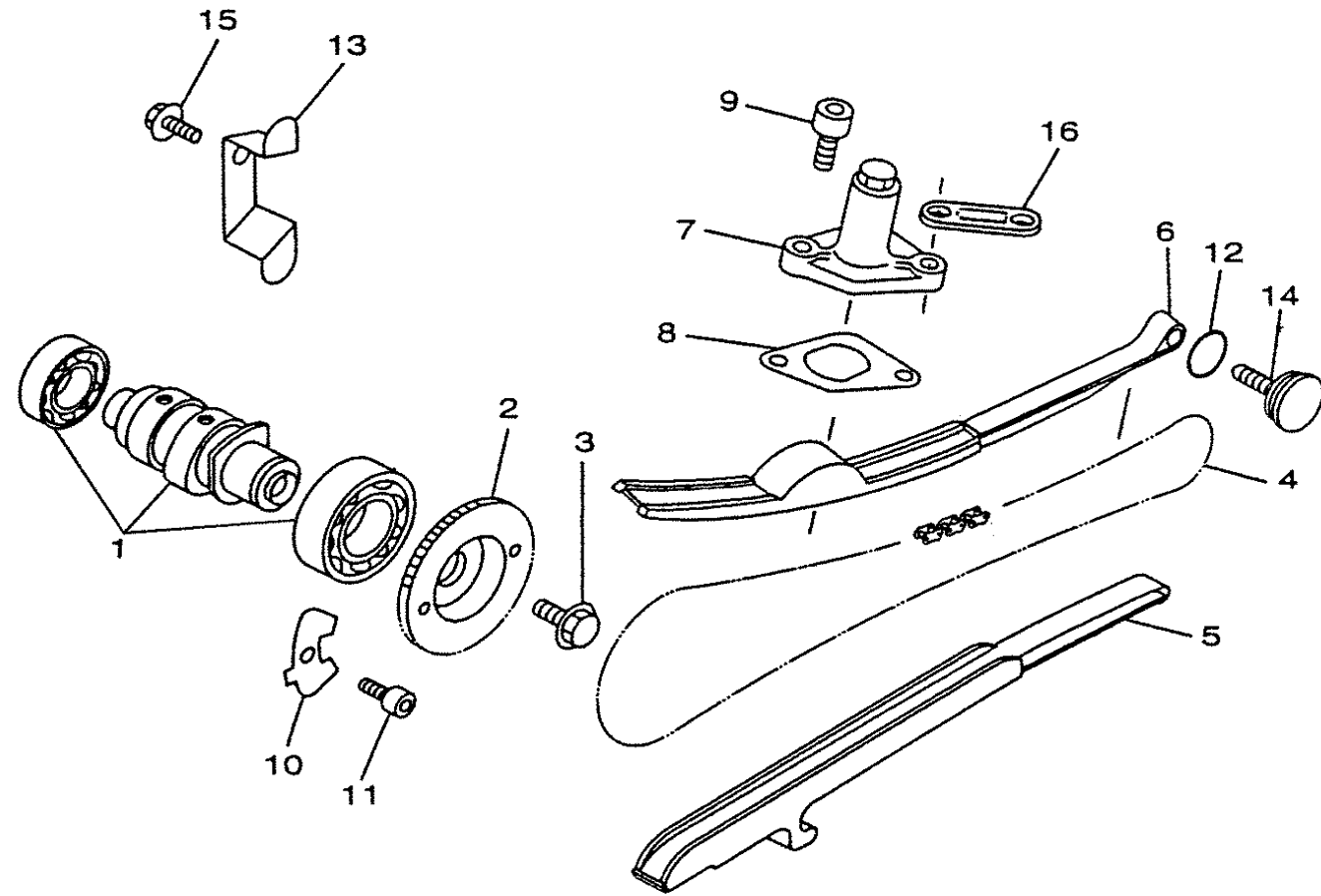


FIG. 4 CAMSHAFT & CHAIN

REF. NO.	PART NO.	DESCRIPTION	5XM3				REMARKS
1	5XL-E2170-00	CAMSHAFT ASSY 1	1				
2	5DS-E2176-00	SPROCKET, CAM CHAIN	1				
3	90105-08825	BOLT, FLANGE	1				
4	94591-48094	CHAIN	1				
5	5NS-E2231-00	GUIDE, STOPPER 1	1				
6	5NS-E2241-00	GUIDE, STOPPER 2	1				
7	50M-12210-00	TENSIONER ASSY, CAM CHAIN	1				
8	4RF-12213-00	GASKET, TENSIONER CASE	1				
9	90110-06X26	BOLT, HEXAGON SOCKET HEAD	2				
10	5DS-E111F-00	PLATE	1				
11	90110-06X21	BOLT, HEXAGON SOCKET HEAD	1				
12	93210-15171	O-RING	1				
13	5DS-E2279-00	PLATE	1				
14	4CW-E2157-00	BOLT	1				
15	90105-06X04	BOLT, FLANGE	1				
16	90462-07X00	CLAMP	1				

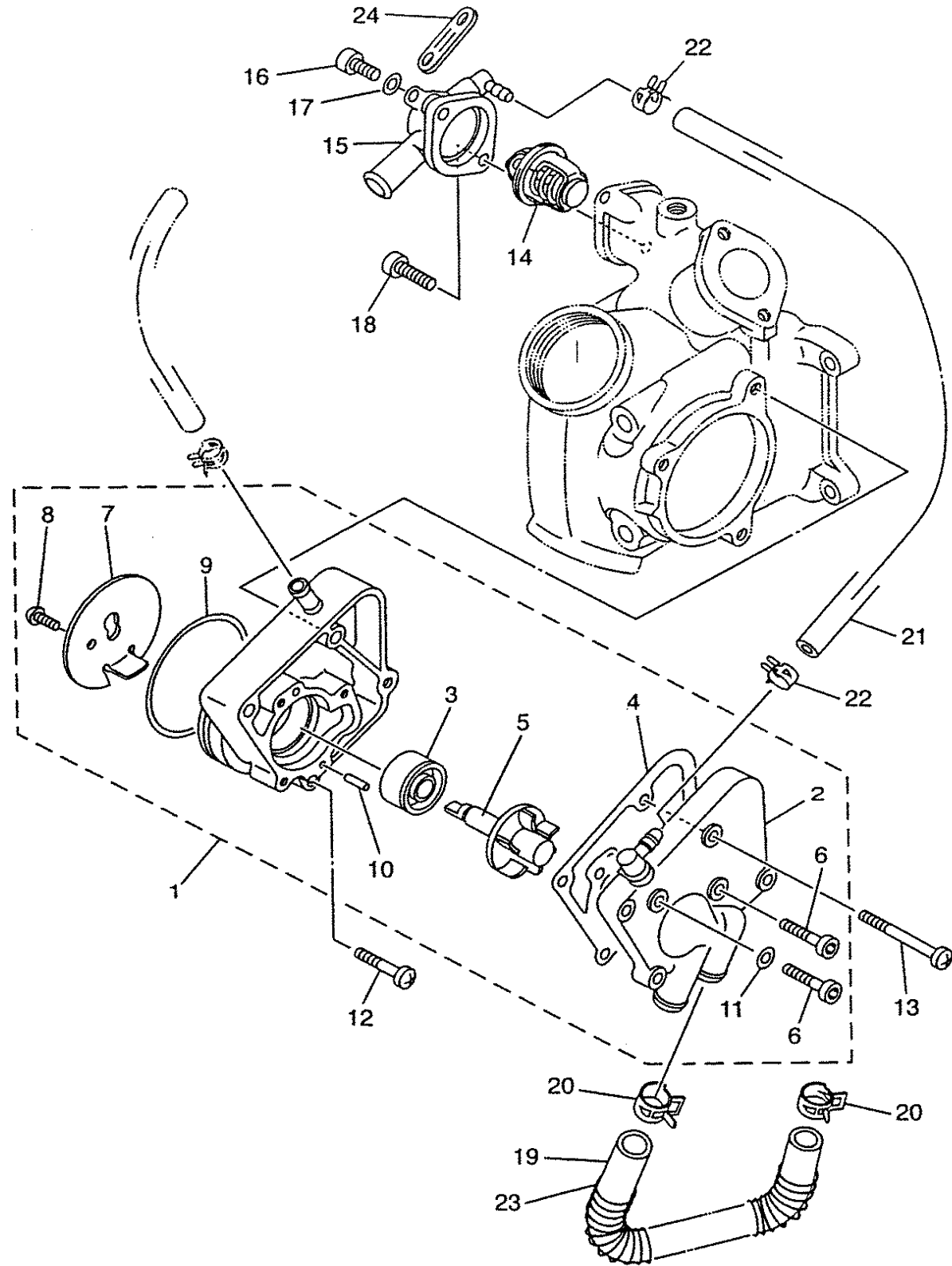


FIG. 5 WATER PUMP

REF. NO.	PART NO.	DESCRIPTION	5XM3				REMARKS
1	5XM-E2420-00	WATER PUMP ASSY	1				
2	5XM-E2422-00	COVER, HOUSING	1				
3	93103-10168	OIL SEAL	1				
4	5DS-E2428-00	GASKET, HOUSING COVER 2	1				
5	5DS-E1185-01	COVER, CYLINDER HEAD SIDE 1	1				
6	5DS-E2450-00	IMPELLER SHAFT ASSY	1				
7	90110-06X04	BOLT, HEXAGON SOCKET HEAD	4				
8	5DS-E1951-00	PLATE	1				
9	90149-06X03	SCREW	1				
10	93210-63X00	O-RING	1				
11	93604-10X00	PIN, DOWEL	2				
12	90430-06X00	GASKET	1				
13	9890N-06025	SCREW, BIND	1				
14	9890N-06050	SCREW, BIND	2				
15	4HC-12411-00	THERMOSTAT	1				
16	5DS-E2413-00	COVER, THERMOSTAT	1				
17	90105-06X04	BOLT, FLANGE	1				
18	90430-06X00	GASKET	1				
19	90110-06X02	BOLT, HEXAGON SOCKET HEAD	2				
20	5DS-E2477-00	PIPE 7	1				
21	90467-20050	CLIP	2				
22	5XL-E2576-00	HOSE 1	2				
23	90467-11108	CLIP	4				
24	90501-10826	SPRING, COMPRESSION	1				
25	90462-07X00	CLAMP	1				

FWD

5XL1300-A050

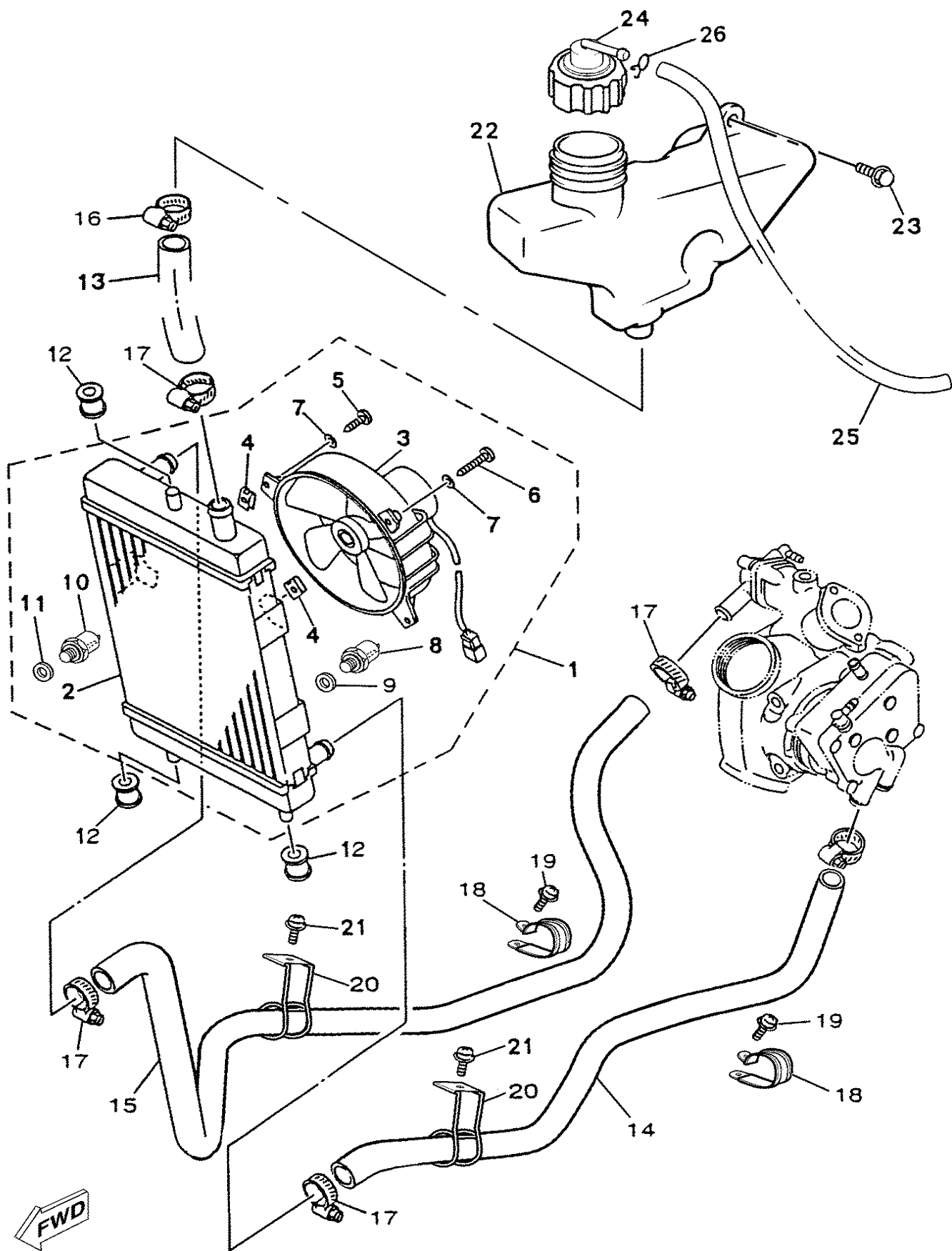
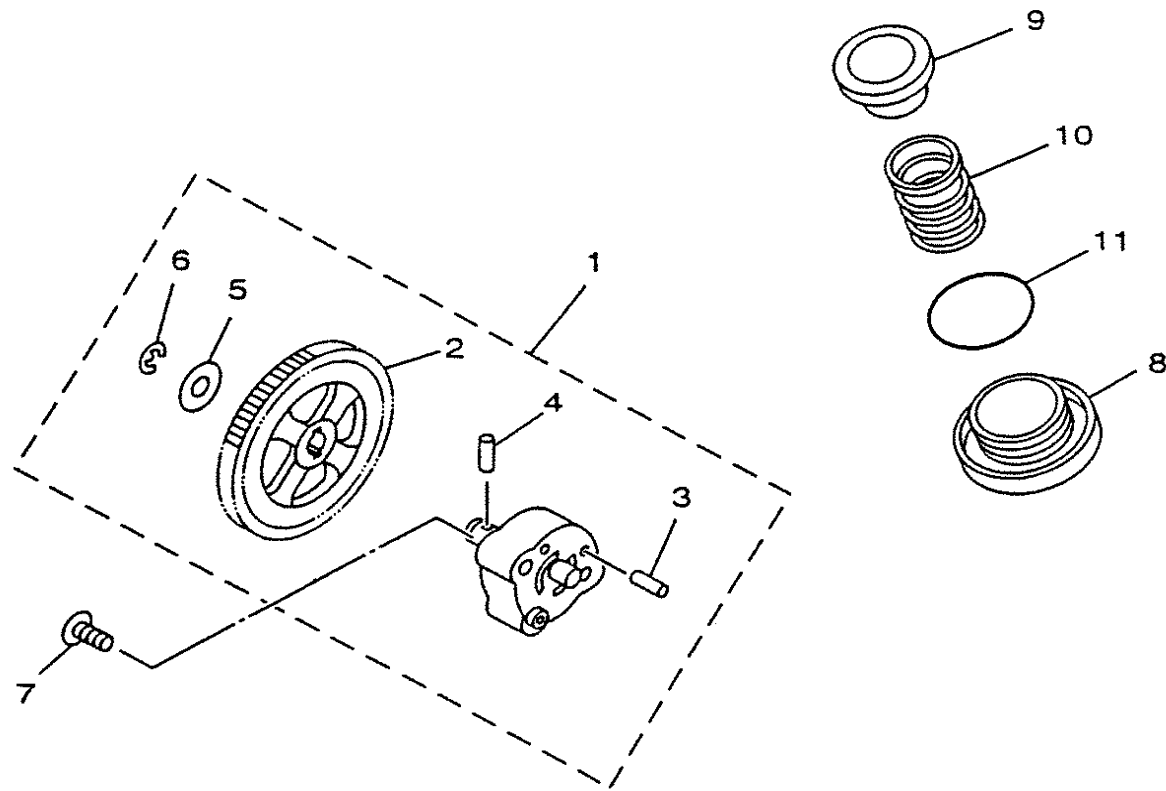


FIG. 6 RADIATOR & HOSE

REF. NO.	PART NO.	DESCRIPTION	5XM3				REMARKS
1	5HT-E240A-00	RADIATOR ASSY	1				
2	5HT-E2460-00	RADIATOR ASSY	1				
3	5DS-E2405-00	BLOWER ASSY	1				
4	5DS-F8317-10	NUT, EMBLEM	3				
5	90167-04X02	SCREW, TAPPING	2				
6	90167-04X03	SCREW, TAPPING	1				
7	90201-05X02	WASHER, PLATE	3				
8	5MF-H2560-00	THERMO SWITCH ASSY	1				
9	5MF-H2558-00	WASHER	1				
10	5HT-H2560-10	THERMO SWITCH ASSY	1				
11	5HT-H2558-00	WASHER	1				
12	90480-20X00	GROMMET	3				
13	5XL-E2481-00	PIPE 1	1				
14	5NR-E2482-00	PIPE 2	1				
15	5NR-E2483-00	PIPE 3	1				
16	90450-27X00	HOSE CLAMP ASSY	1				
17	90450-27X00	HOSE CLAMP ASSY	5				
18	5NR-E2491-00	CLAMP 1	2				
19	90159-06835	SCREW, WITH WASHER	2				
20	5NR-E2492-00	CLAMP 2	2				
21	90159-06835	SCREW, WITH WASHER	2				
22	5XL-F1871-00	TANK, RECOVERY	1				
23	90119-06X02	BOLT, WITH WASHER	2				
24	5MF-E2462-01	CAP, RADIATOR	1				
25	5XL-F1817-00	PIPE 2	1				

5XL1300-A060

FIG. 7 OIL PUMP



REF. NO.	PART NO.	DESCRIPTION	5XM3				REMARKS
1	5CA-E3300-00	OIL PUMP ASSY	1				
2	3UH-E3325-00	.GEAR, PUMP DRIVEN	1				
3	93603-12833	.PIN, DOWEL	2				
4	93602-13832	.PIN, DOWEL	1				
5	90201-077F5	.WASHER, PLATE	1				
6	99001-05600	.CIRCLIP	1				
7	98707-06020	SCREW, FLAT HEAD	2				
8	5DS-E5351-00	PLUG, DRAIN	1				
9	3KW-E3411-00	STRAINER, OIL	1				
10	90501-16829	SPRING, COMPRESSION	1				
11	93210-347A1	O-RING	1				



5NR8300-1070

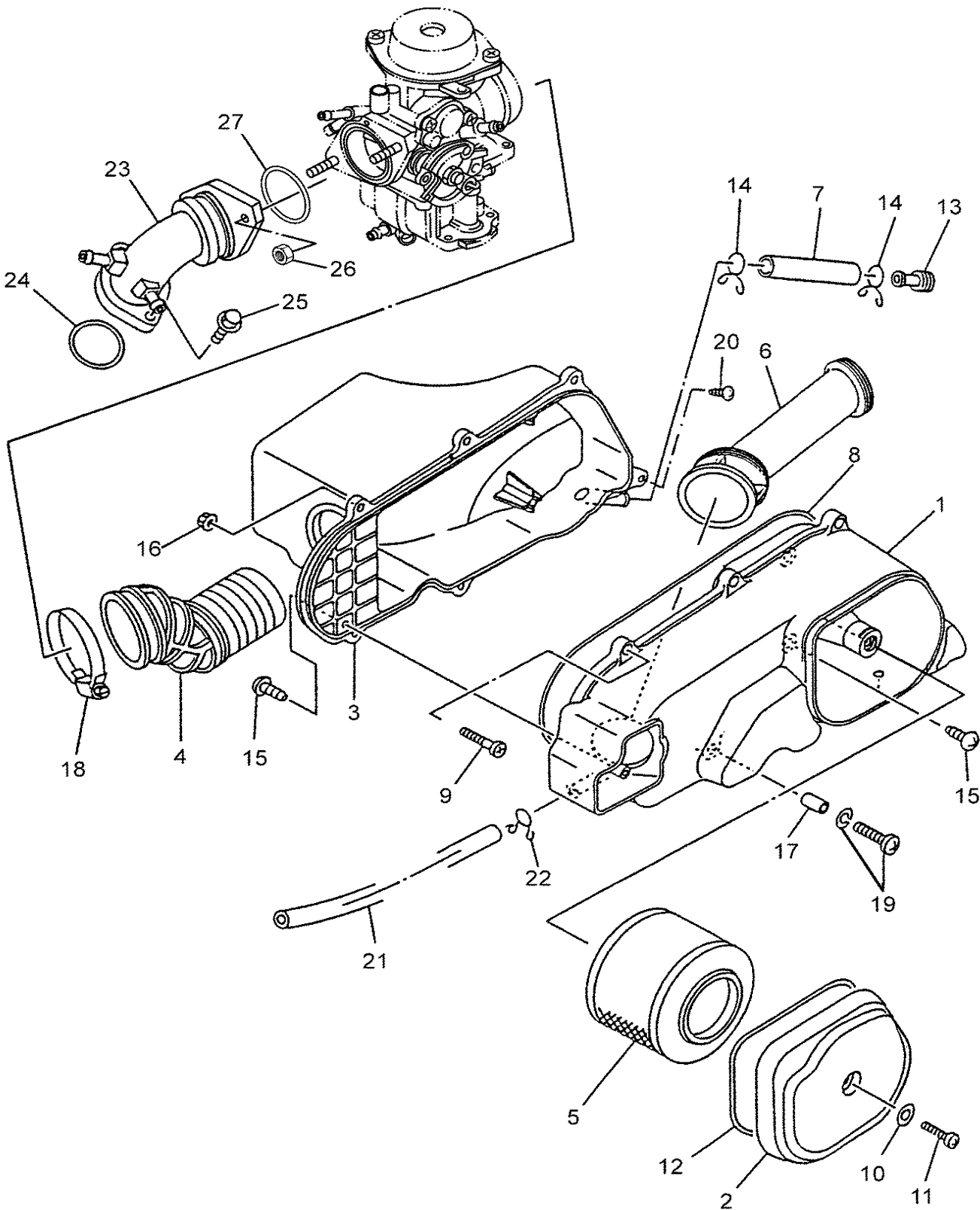


FIG. 8 INTAKE

REF. NO.	PART NO.	DESCRIPTION	5XM3				REMARKS
1	5DS-E4411-01	CASE, AIR CLEANER 1	1				
2	5DS-E4412-00	CAP, CLEANER CASE 1	1				
3	5DS-E4422-01	CAP, CLEANER CASE 2	1				
4	5DS-E4453-00	JOINT, AIR CLEANER 1	1				
5	5DS-E4451-00	ELEMENT, AIR CLEANER	1				
6	5DS-E4437-00	DUCT	1				
7	90446-14X00	HOSE	1				
8	5DS-E4452-00	SEAL	1				
9	9850M-06020	SCREW, PAN HEAD	6				
10	90201-062A8	WASHER, PLATE	1				
11	90154-06X06	SCREW, BINDING	1				
12	5DS-E4476-00	SEAL	1				
13	5DS-E446M-00	COVER, DRAIN VALVE	1				
14	90467-12X00	CLIP	2				
15	90167-04X00	SCREW, TAPPING	2				
16	9530L-06600	NUT	6				
17	90387-06X03	COLLAR	2				
18	90450-60X01	HOSE CLAMP ASSY	1				
19	9760M-06130	SCREW, PAN HEAD WITH WASHER	2				
20	90167-04X02	SCREW, TAPPING	1				
21	5DS-E4349-00	PIPE	1				
22	90467-11X01	CLIP	2				
23	5XM-E3585-00	MANIFOLD	1				
24	93210-35537	O-RING	1				
25	90149-06X07	SCREW	2				
26	93210-35537	O-RING	1				
27	90179-06X04	NUT	2				



5XL1300-A080

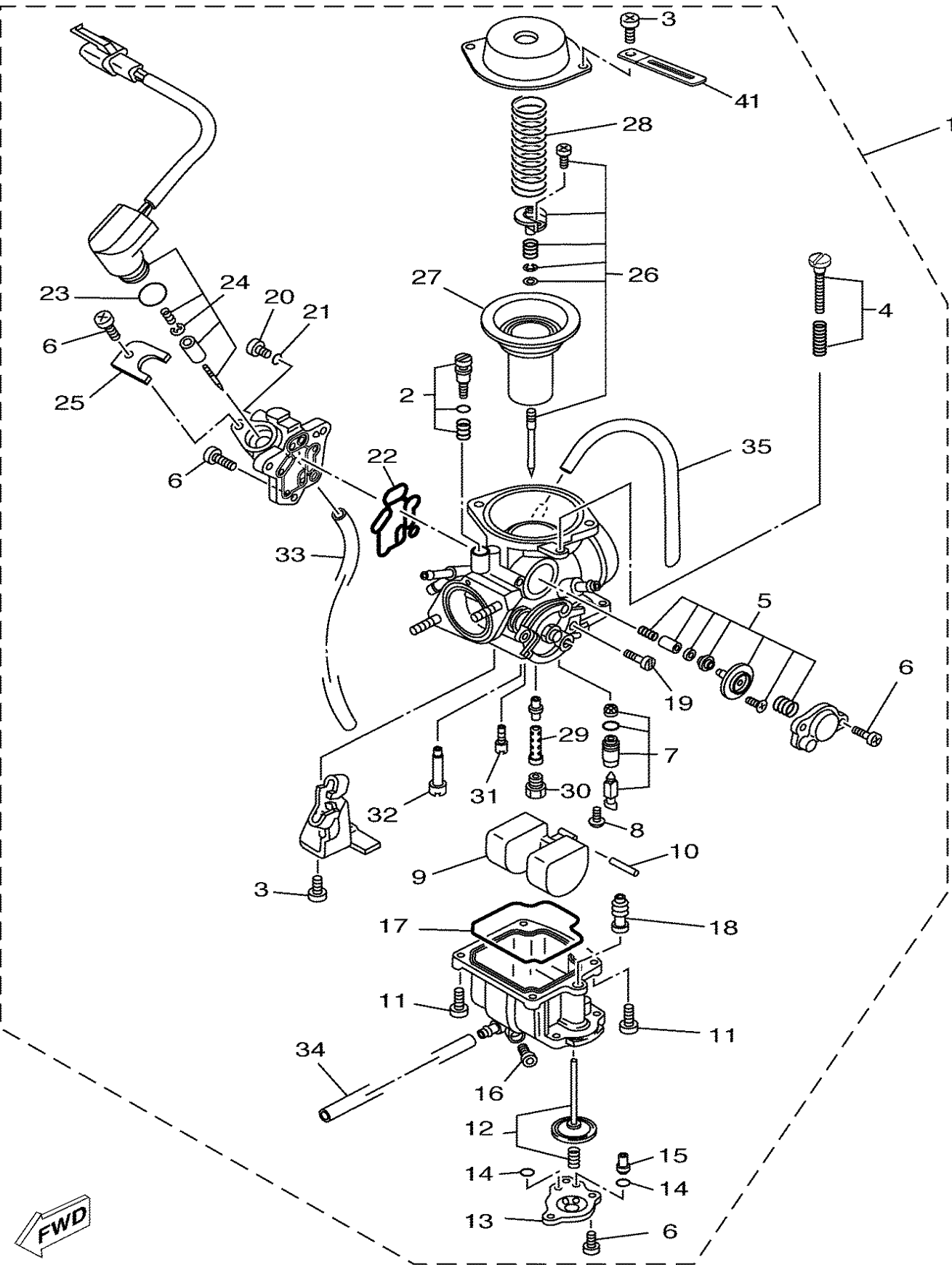


FIG. 9 CARBURETOR

REF. NO.	PART NO.	DESCRIPTION	5XM3				REMARKS
1	5XM-E4301-00	CARBURETOR ASSY 1	1				
2	5XL-14105-00	.PILOT SCREW SET	1				
3	97801-05010	.THROTTLE SCREW	4				
4	5XL-14103-00	.THROTTLE SCREW SET	1				
5	5XL-1490A-00	.DIAPHRAGM SET 1	1				
6	214-24535-00	.SCREW, LEVER FITTING	9				
7	4HC-14390-25	.NEEDLE VALVE ASSY	1				
8	98901-04006	.SCREW, BIND	1				
9	25N-14385-00	.FLOAT	1				
10	4FP-14386-00	.PIN, FLOAT	1				
11	98501-04012	.SCREW, PAN HEAD	4				
12	4HC-14940-00	.DIAPHRAGM ASSY	1				
13	4HC-14958-00	.COVER, DIAPHRAGM	1				
14	389-14147-00	.O-RING	2				
15	4KL-14272-01	.VALVE, CHECK SEAT	1				
16	4JP-14323-00	.DRAIN, SCRE	1				
17	4KL-14384-00	.GASKET, FLOAT CHAMBER	1				
18	4KL-14404-00	.BOOT	1				
19	4HC-14429-00	.SCREW	1				
20	4HC-14592-00	.SCREW	1				
21	5H0-14397-00	.O-RING	1				
22	4KL-14536-00	.GASKET	1				
23	4KL-14397-00	.O-RING	1				
24	5XL-1410A-00	.STARTER SET	1				
25	4JP-14243-01	.PLATE	1				
26	5XM-1490J-00	.NEEDLE SET	1				
27	4HC-14340-01	.VALVE ASSY	1				

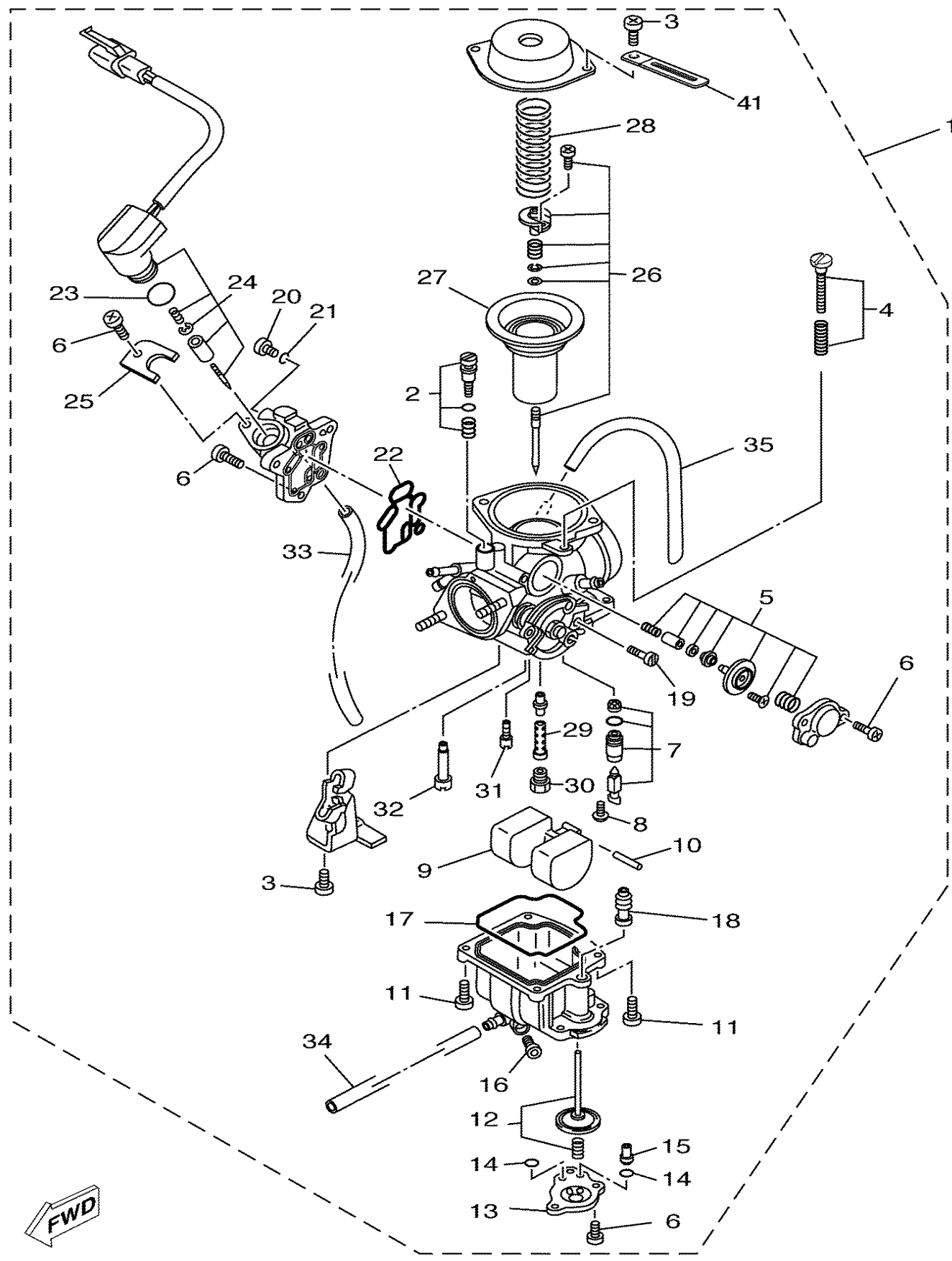


5XL1300-A090

B10

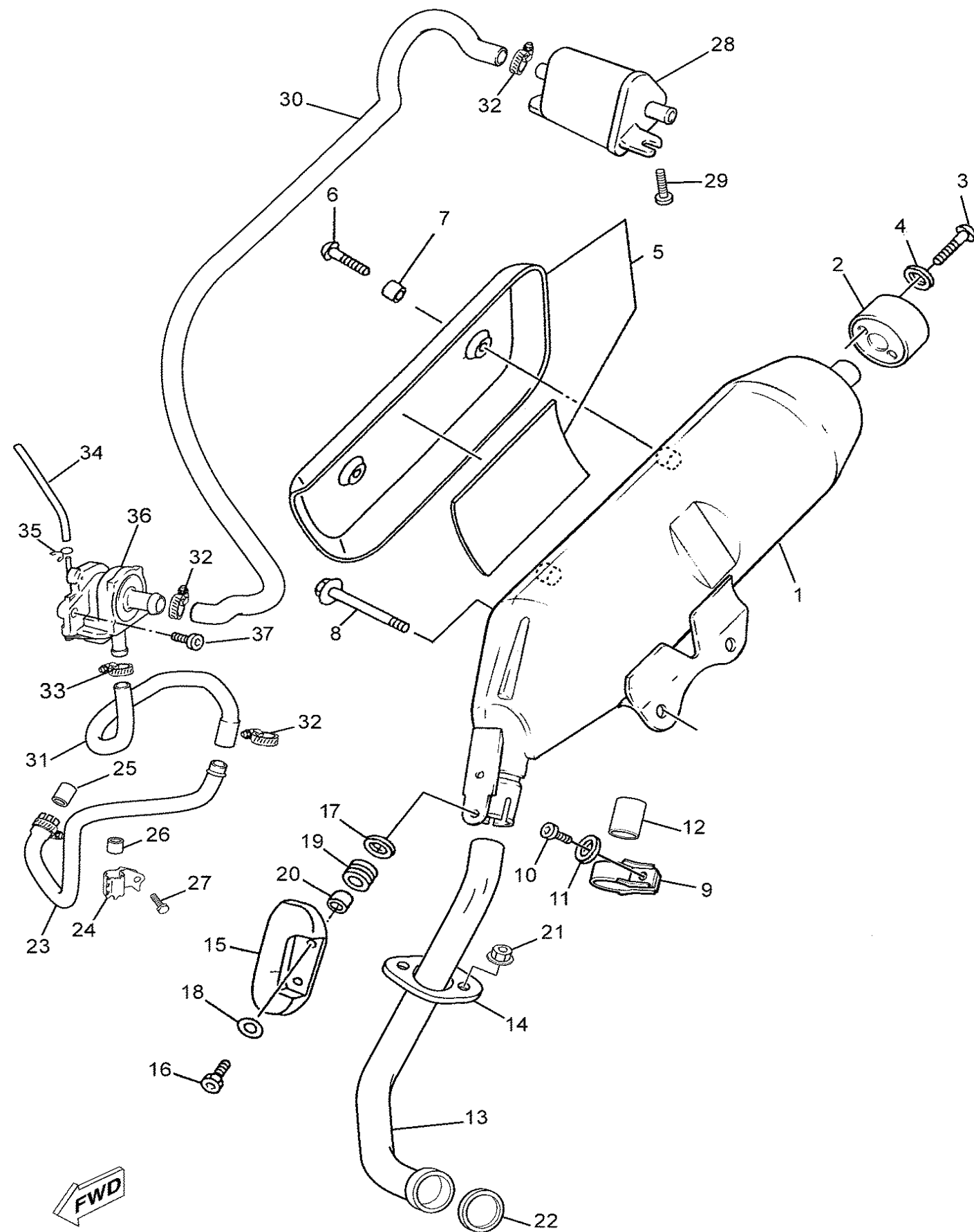


FIG. 9 CARBURETOR



REF. NO.	PART NO.	DESCRIPTION	5XM3					REMARKS
28	5SE-14286-00	.SPRING	1					
29	5SE-14341-00	.NOZZLE, MAIN	1					
30	50M-14343-56	.JET, MAIN (#112)	1					
31	38V-14342-22	.JET, PILOT (# 44)	1					
32	50M-14355-00	.PLUG	1					
33	4HC-14197-00	.PIPE	1					
34	4HC-14196-00	.PIPE	1					
35	5XL-14197-00	.PIPE	1					
36	4KL-14415-00	.HOLDER, WIRE	1					

5XL1300-A090

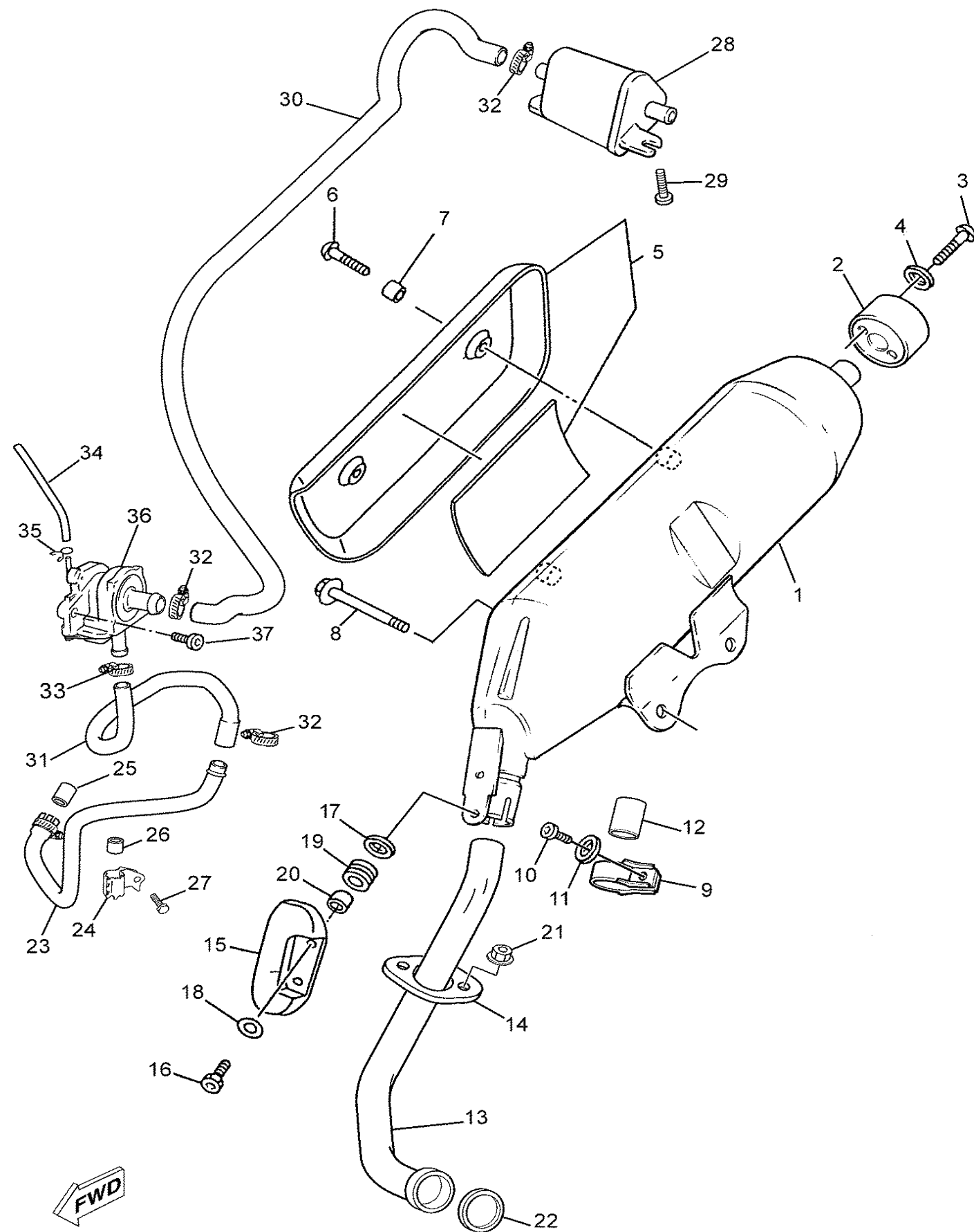


5XL3300-C100

FIG. 10 EXHAUST

REF. NO.	PART NO.	DESCRIPTION	5XM3				REMARKS
1	5XM-E4711-00	MUFFLER 1	1				
2	5HT-E479X-00	PIPE	1				
3	90110-06X51	BOLT, HEXAGON SOCKET HEAD	2				
4	90201-06X01	WASHER, PLATE	2				
5	5XL-E4718-00-LK	PROTECTOR, MUFFLER 1	1				FIS
6	9890L-06016	SCREW, BIND	2				
7	90387-06X26	COLLAR	1				
8	9582M-10030	BOLT, FLANGE	2				
9	5HT-E4788-01	BAND, SILENCER	1				
10	9131L-08020	BOLT	1				
11	90201-08X16	WASHER, PLATE	1				
12	5HT-E4714-00	GASKET, MUFFLER	1				
13	5NR-E4611-00	PIPE, EXHAUST 1	1				
14	5NR-E4614-00	FLANGE, EXHAUST PIPE	1				
15	5DS-E4628-00	PROTECTOR, EXHAUST PIPE	1				
16	9131L-06016	BOLT	2				
17	9290M-06200	WASHER	2				
18	3WG-E4766-10	WASHER, PROTECTOR	2				
19	90480-12237	GROMMET	2				
20	90387-060G7	COLLAR	2				
21	95607-08200	NUT, SELF-LOCKING	2				
22	5DS-E4613-00	GASKET, EXHAUST PIPE	1				
23	5XL-E4872-00	PIPE 2	1				
24	5XL-E479U-00	GUIDE 1	1				
25	42H-14714-10	GASKET, MUFFLER	1				
26	90480-11X04	GROMMET	1				
27	9131M-06012	BOLT	1				



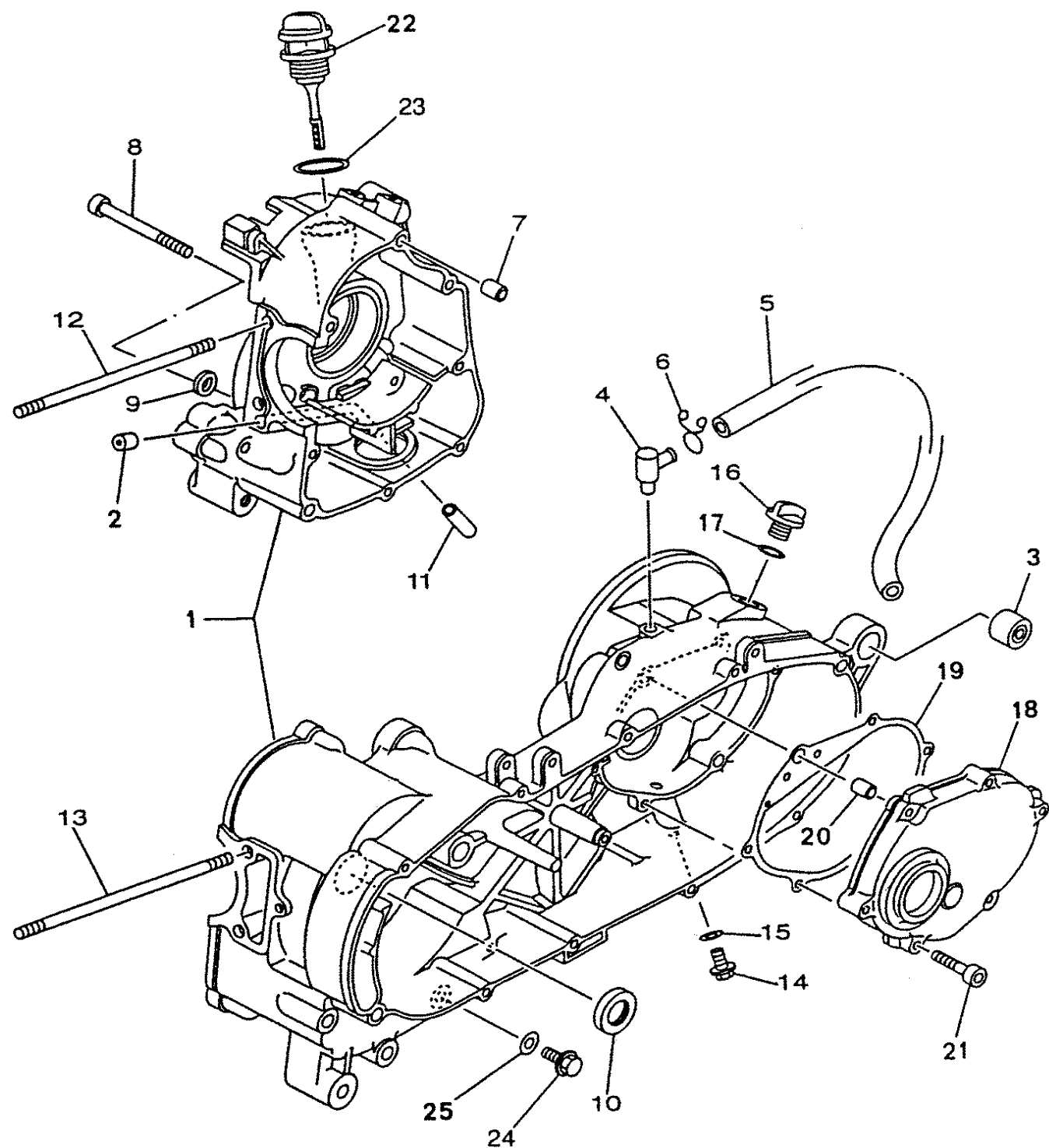


5XL3300-C100

FIG. 10 EXHAUST

REF. NO.	PART NO.	DESCRIPTION	5XM3				REMARKS
28	4CW-E4806-00	AIR FILTER CASE ASSY.	1				
29	9580M-06012	BOLT, FLANGE	2				
30	5XL-E4884-00	HOSE, BEND 4	1				
31	5XL-E4883-00	HOSE, BEND 3	1				
32	90467-16X00	CLIP	3				
33	90467-15X00	CLIP	1				
34	5NR-E3542-00	HOSE, VACUUM SENSING 1	1				
35	90467-09X00	CLIP	1				
36	5GM-14803-00	AIR INDUCTION SYSTEM ASSY	1				
37	9131M-06020	BOLT	2				

FIG. 11 CRANKCASE



REF. NO.	PART NO.	DESCRIPTION	5XM3				REMARKS
1	5XM-E5100-00	CRANKCASE ASSY	1				
2	5DS-E5138-00	NOZZLE 1	1				
3	4X6-F2216-00	BUSH, REAR SHOCK ABSORBER	1				
4	3VL-E5371-10	BREATHER	1				
5	5DS-E5373-10	PIPE, BREATHER	1				
6	90467-11106	CLIP	1				
7	99530-10114	PIN, DOWEL	2				
8	9131N-06080	BOLT	8				
9	90430-06014	GASKET	2				
10	93102-22294	OIL SEAL	1				
11	3UH-E3416-00	PIPE, OIL 1	1				
12	90116-08625	BOLT, STUD	2				
13	90116-08624	BOLT, STUD	2				
14	95817-08016	BOLT, FLANGE	1				
15	90430-08816	GASKET	1				
16	3VL-E5363-00	PLUG, OIL	1				
17	93210-14104	O-RING	1				
18	5KD-E5421-00	COVER, CRANKCASE 2	1				
19	5DS-E5461-10	GASKET, CRANKCASE COVER 2	1				
20	*	PIN, DOWEL	2				
21	90110-06X05	BOLT, HEXAGON SOCKET HEAD	6				
22	5DS-E5363-00	PLUG, OIL	1				
23	93210-26130	O-RING	1				
24	95817-08016	BOLT, FLANGE	1				
25	90430-08816	GASKET	1				



5XL1300-A110

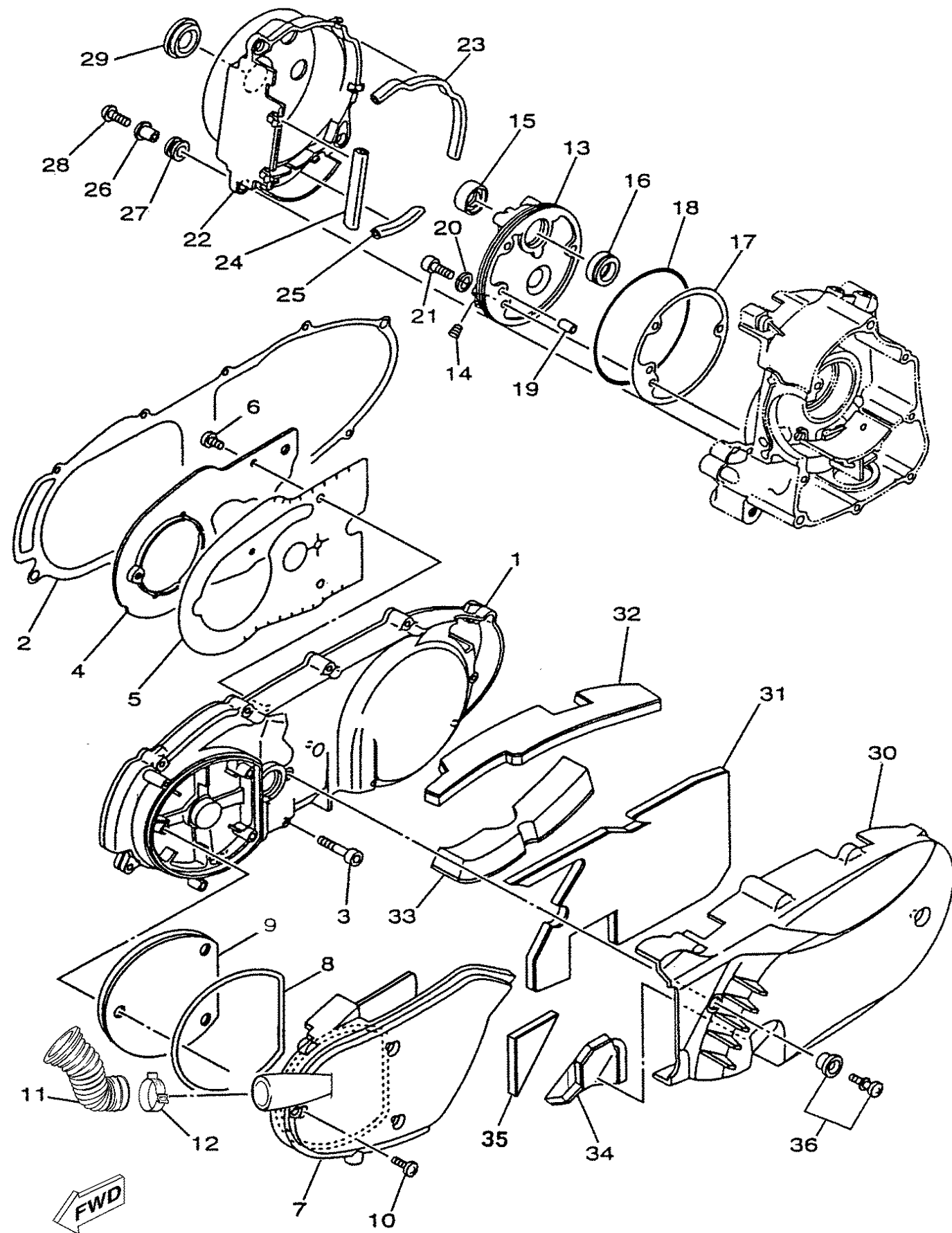


FIG. 12 CRANKCASE COVER 1

REF. NO.	PART NO.	DESCRIPTION	5XM3				REMARKS
1	5DS-E5411-00	COVER, CRANKCASE 1	1				
2	5DS-E5451-10	GASKET, CRANKCASE COVER 1	1				
3	90110-06X06	BOLT, HEXAGON SOCKET HEAD	11				
4	5DS-E5191-00	PLATE	1				
5	5DS-E5455-00	GASKET 1	1				
6	90149-06X03	SCREW	3				
7	5XM-E5471-00	DUCT, AIR	1				
8	5DS-E5472-00	SEAL, AIR DUCT	1				
9	5DS-15407-01	ELEMENT 1	1				
10	9890N-06020	SCREW, BIND	3				
11	5XL-F838N-00	DUCT 1	1				
12	90464-80X00	CLAMP	1				
13	5DS-E5417-00	COVER, CAP	1				
14	90336-07034	PLUG, TAPER	1				
15	93102-19477	OIL SEAL	1				
16	93101-19172	OIL SEAL	1				
17	5DS-E5453-00	GASKET	1				
18	93211-077A5	O-RING	1				
19	99530-08012	PIN, DOWEL	1				
20	90430-06014	GASKET	3				
21	90110-06X03	BOLT, HEXAGON SOCKET HEAD	3				
22	5DS-E5426-00	COVER, OIL PUMP 2	1				
23	5DS-E542A-00	DAMPER 1	1				
24	5DS-E542B-00	DAMPER 2	1				
25	5DS-E542C-00	DAMPER 3	1				
26	90387-068F9	COLLAR	3				
27	90480-12X01	GROMMET	3				

5XL1300-A120



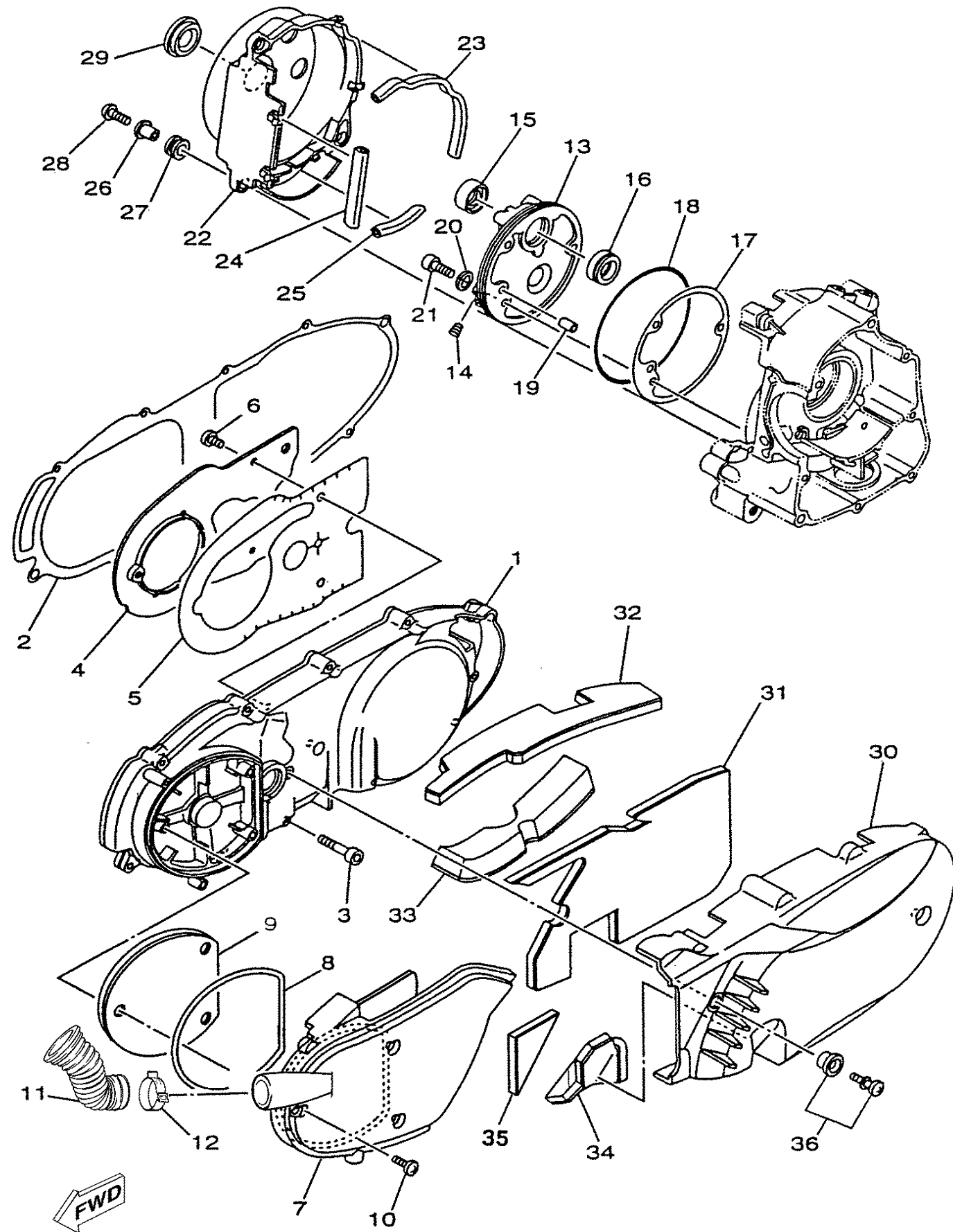


FIG. 12 CRANKCASE COVER 1

REF. NO.	PART NO.	DESCRIPTION	5XM3				REMARKS
28	9890N-06020	SCREW, BIND	3				
29	90480-30X00	GROMMET	1				
30	5XM-E5431-00	COVER, CRANKCASE 3	1				
31	5MF-E5316-00	DAMPER, ENGINE MOUNT 1	1				
32	5MF-E5326-00	DAMPER, ENGINE MOUNT 2	1				
33	5MF-E5335-00	DAMPER 3	1				
34	5MF-E5337-00	DAMPER 4	1				
35	5MF-E5338-00	DAMPER, ENGINE MOUNT 5	1				
36	3KJ-15481-00	BOLT 1	2				

5XL1300-A120

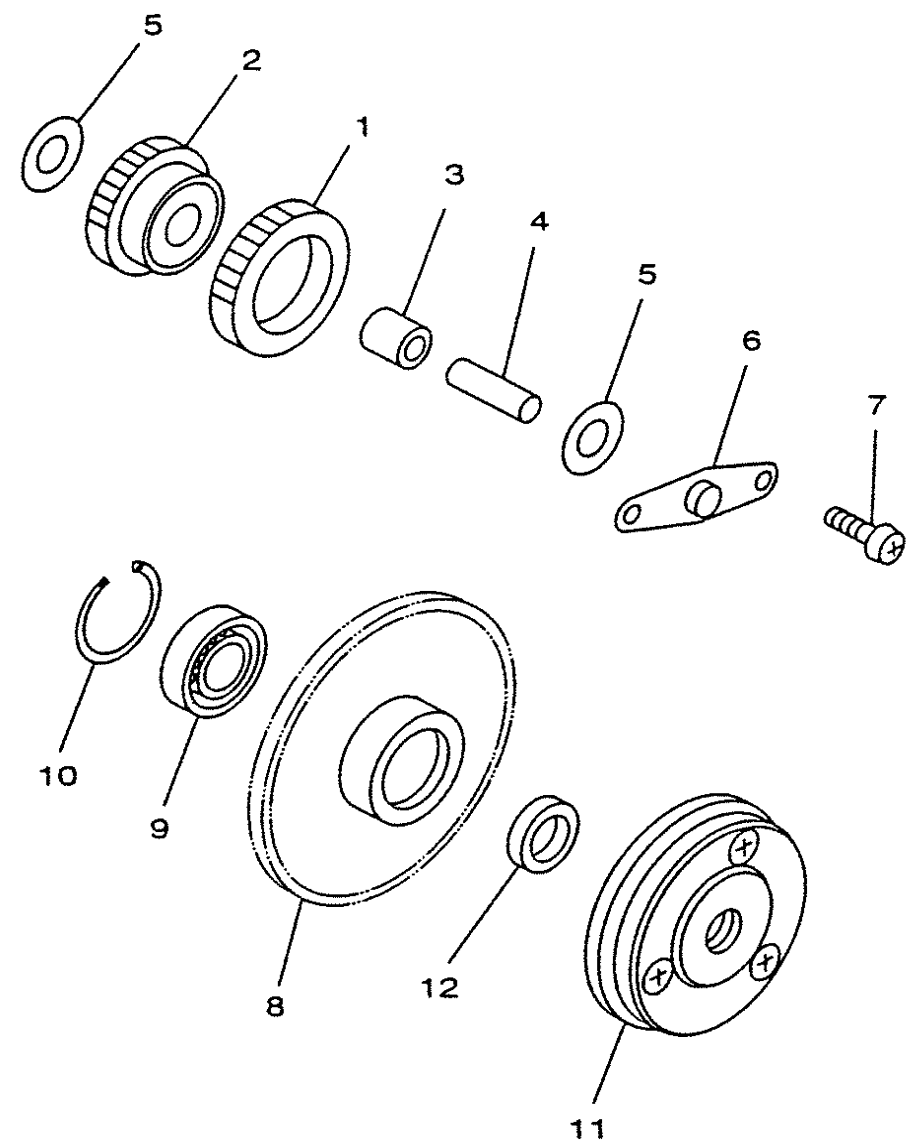


FIG. 13 STARTER

REF. NO.	PART NO.	DESCRIPTION	5XM3				REMARKS
1	3UH-E5512-00	GEAR, IDLER 1	1				
2	3UH-E5517-00	GEAR, IDLER 2	1				
3	93315-110Y0	BEARING	1				
4	5DS-E5521-00	SHAFT 1	1				
5	90201-108A3	WASHER, PLATE	2				
6	5DS-E5532-00	PLATE, IDLE GEAR	1				
7	90149-06X03	SCREW	2				
8	5XM-15524-00	WHEEL, STARTER	1				
9	93306-003Y9	BEARING	1				
10	93450-35015	CIRCLIP	1				
11	5XM-E5570-00	STARTER CLUTCH ASSY	1				
12	90387-168S2	COLLAR	1				



5NR8300-1130

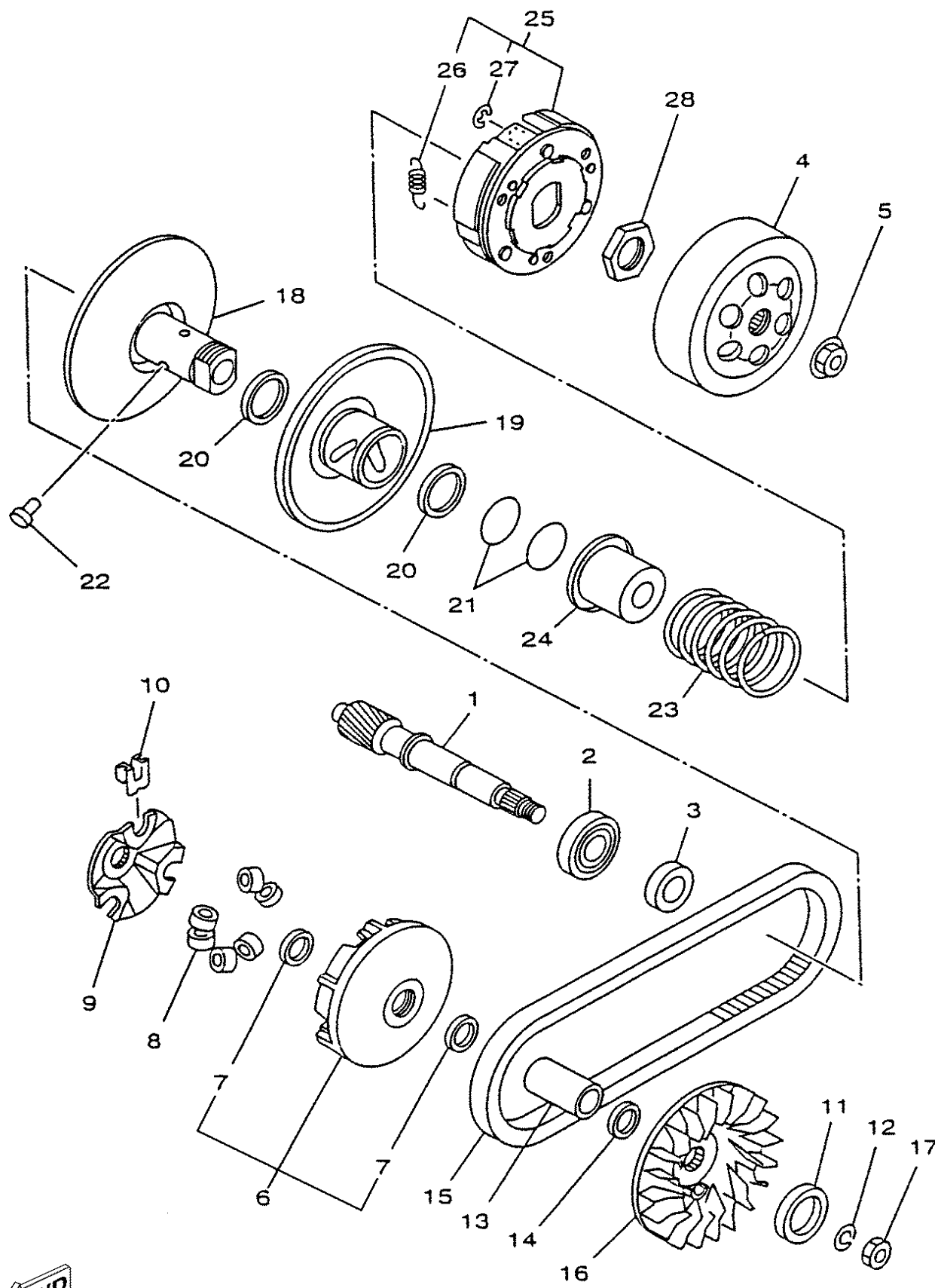


FIG. 14 CLUTCH

REF. NO.	PART NO.	DESCRIPTION	5XM3				REMARKS
1	5KD-E6111-00	GEAR, PRIMARY DRIVE	1				
2	93306-205X8	BEARING	1				
3	93102-25800	OIL SEAL	1				
4	5KD-E6611-00	CLUTCH HOUSING COMP.	1				
5	90179-14469	NUT	1				
6	5DS-E7620-00	PRIMARY SLIDING SHEAVE COMP.	1				
7	93101-21170	OIL SEAL	2				
8	5XM-E7632-00	WEIGHT	6				
9	5XL-E7623-00	CAM	1				
10	5DS-E7653-00	SLIDER	3				
11	90201-16X04	WASHER, PLATE	1				
12	90208-12050	WASHER, CONICAL SPRING	1				
13	90387-168D2	COLLAR	1				
14	90201-16X09	WASHER, PLATE	1				
15	5XM-E7641-00	V-BELT	1				
16	5DS-E7611-00	SHEAVE, PRIMARY FIXED	1				
17	90170-12X01	NUT	1				
18	5XM-E7660-00	SECONDARY FIXED SHEAVE COMP.	1				
19	5XM-E7670-00	SECONDARY SLIDING SHEAVE	1				
20	93104-41802	OIL SEAL	2				
21	93210-43X00	O-RING	2				
22	5DS-E7664-00	PIN, GUIDE	3				
23	90501-04X00	SPRING, COMPRESSION	1				
24	5DS-E7684-00	SEAT, SECONDARY SPRING	1				
25	5XM-E6620-00	CLUTCH CARRIER ASSY	1				
26	5XM-E6626-00	SPRING, CLUTCH WEIGHT 1	3				
27	93430-08X00	CIRCLIP	3				



5XL1300-A140



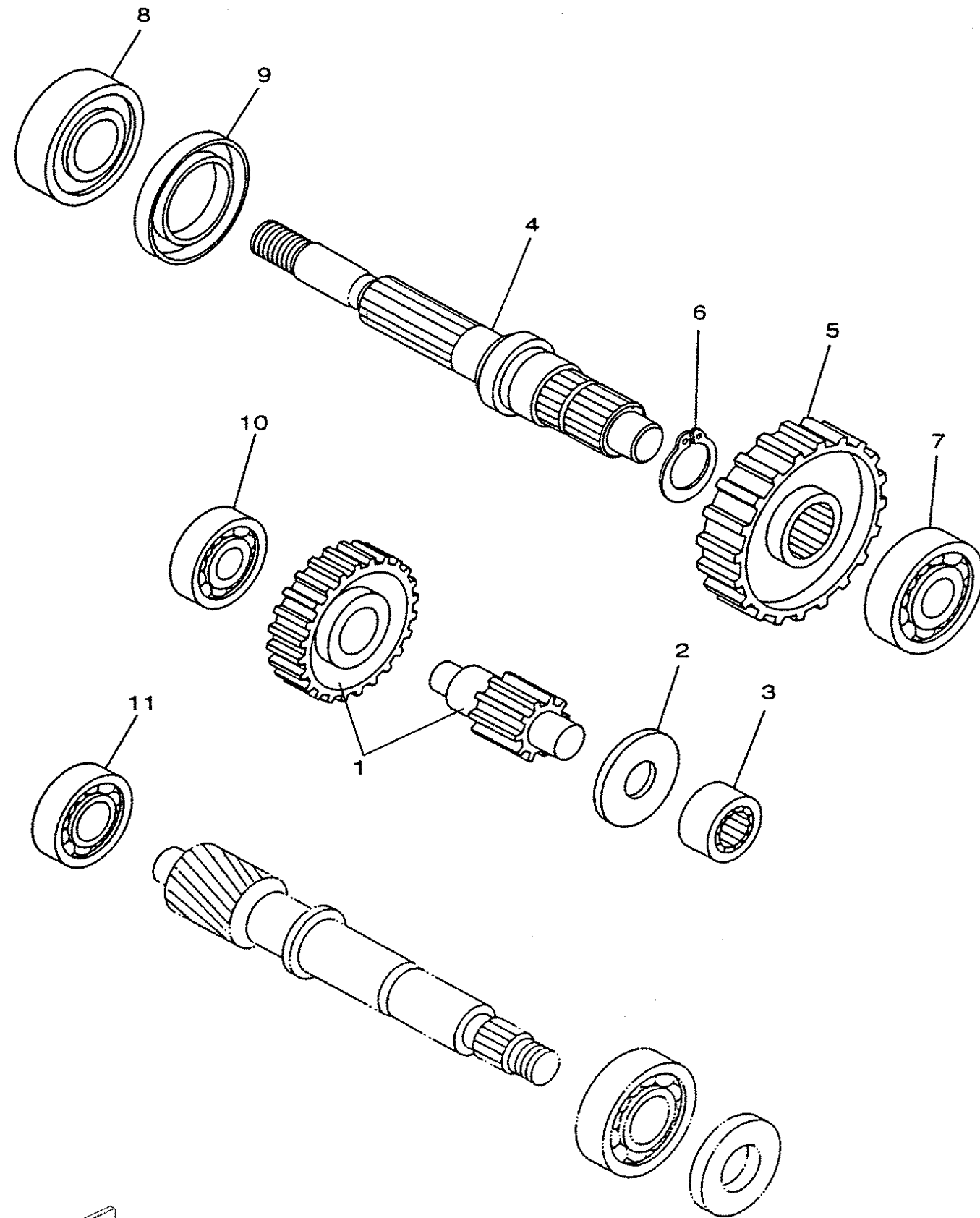


FIG. 15 TRANSMISSION

REF. NO.	PART NO.	DESCRIPTION	5XM3				REMARKS
1	5KD-E7410-00	MAIN AXLE COMP.	1				
2	90201-15X01	WASHER, PLATE	2				
3	93311-315Y4	BEARING	1				
4	5NS-E7421-00	AXLE, DRIVE	1				
5	5KD-E7211-00	GEAR, 1ST WHEEL	1				
6	99009-25400	CIRCLIP	1				
7	93306-303X2	BEARING	1				
8	93306-272Y1	BEARING	1				
9	93102-32298	OIL SEAL	1				
10	93306-301XB	BEARING	1				
11	93306-203YC	BEARING	1				

5NR8300-1150

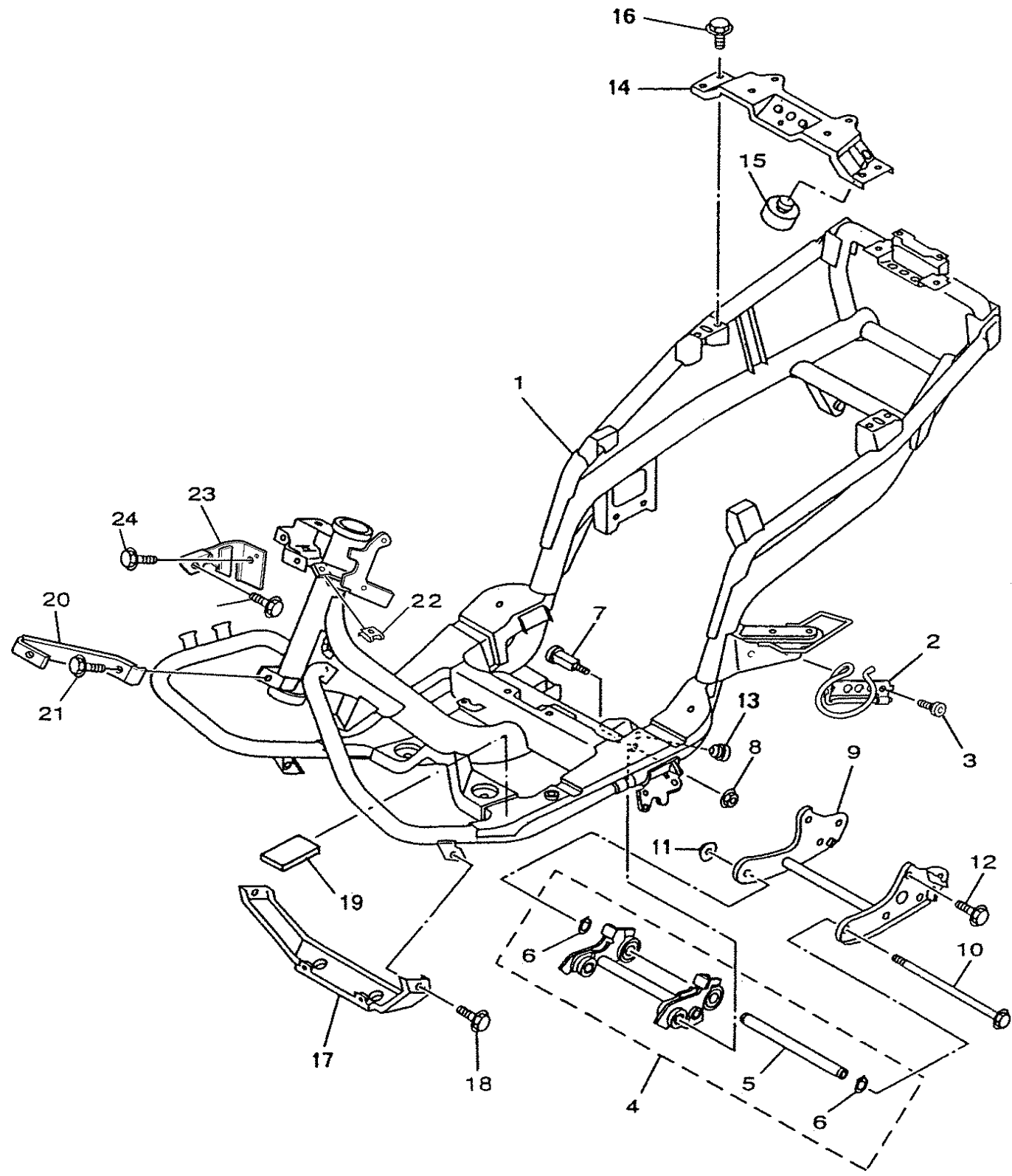


FIG. 16 FRAME

REF. NO.	PART NO.	DESCRIPTION	5XM3				REMARKS
1	5XL-F1110-00-33	FRAME COMP.	1				YB
2	5XL-F117A-00	STAY	1				
3	9580M-06012	BOLT, FLANGE	1				
4	5DS-F1420-00	ENGINE BRACKET COMP. 2	1				
5	5DS-E5317-00	.SPACER, ENGINE MOUNT	1				
6	99009-17400	.CIRCLIP	2				
7	5DS-F1481-00	BOLT, ENGINE MOUNTING 1	2				
8	90185-10840	NUT, SELF-LOCKING	2				
9	5DS-F1410-01	ENGINE BRACKET COMP.	1				
10	90105-106A2	BOLT, FLANGE	1				
11	90185-10840	NUT, SELF-LOCKING	1				
12	9582M-10030	BOLT, FLANGE	4				
13	2JW-F7114-10	STOPPER, MAIN STAND	2				
14	5DS-F1232-00	REINFORCEMENT, TAIL	1				
15	2RN-F4741-00	PAD, SEAT	2				
16	9580L-06016	BOLT, FLANGE	4				
17	5NR-F142N-00	BRACKET, RADIATOR	1				
18	9582M-08012	BOLT, FLANGE	2				
19	5DS-F7414-00	DAMPER, FOOTREST	2				
20	5NR-F118V-00	BRACKET 4	1				
21	9580M-06012	BOLT, FLANGE	1				
22	90183-06816	NUT, SPRING	1				
23	5XL-F116A-00	STAY 1	1				
24	9580L-06012	BOLT, FLANGE	1				

FWD
5XL1300-A160

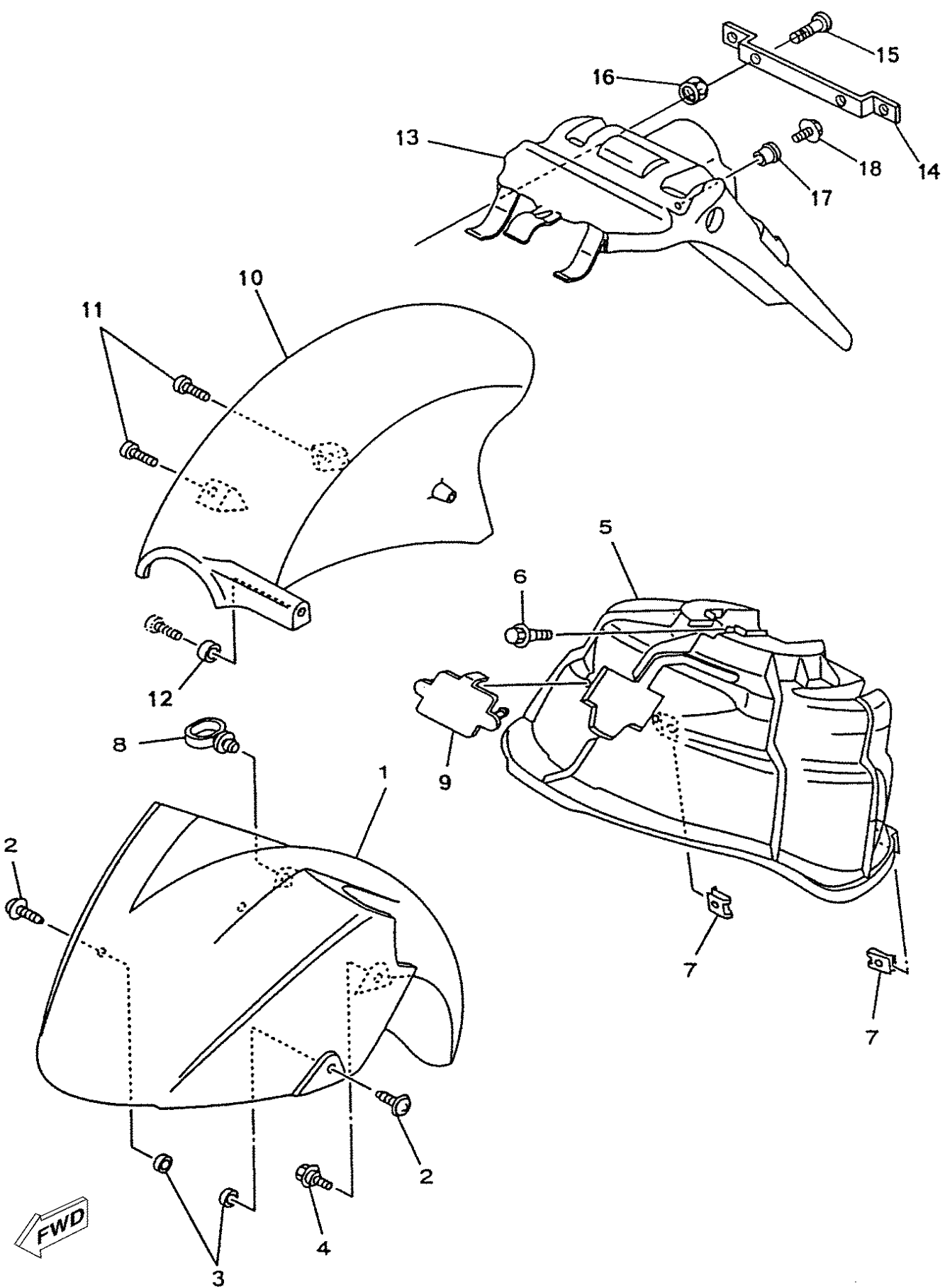
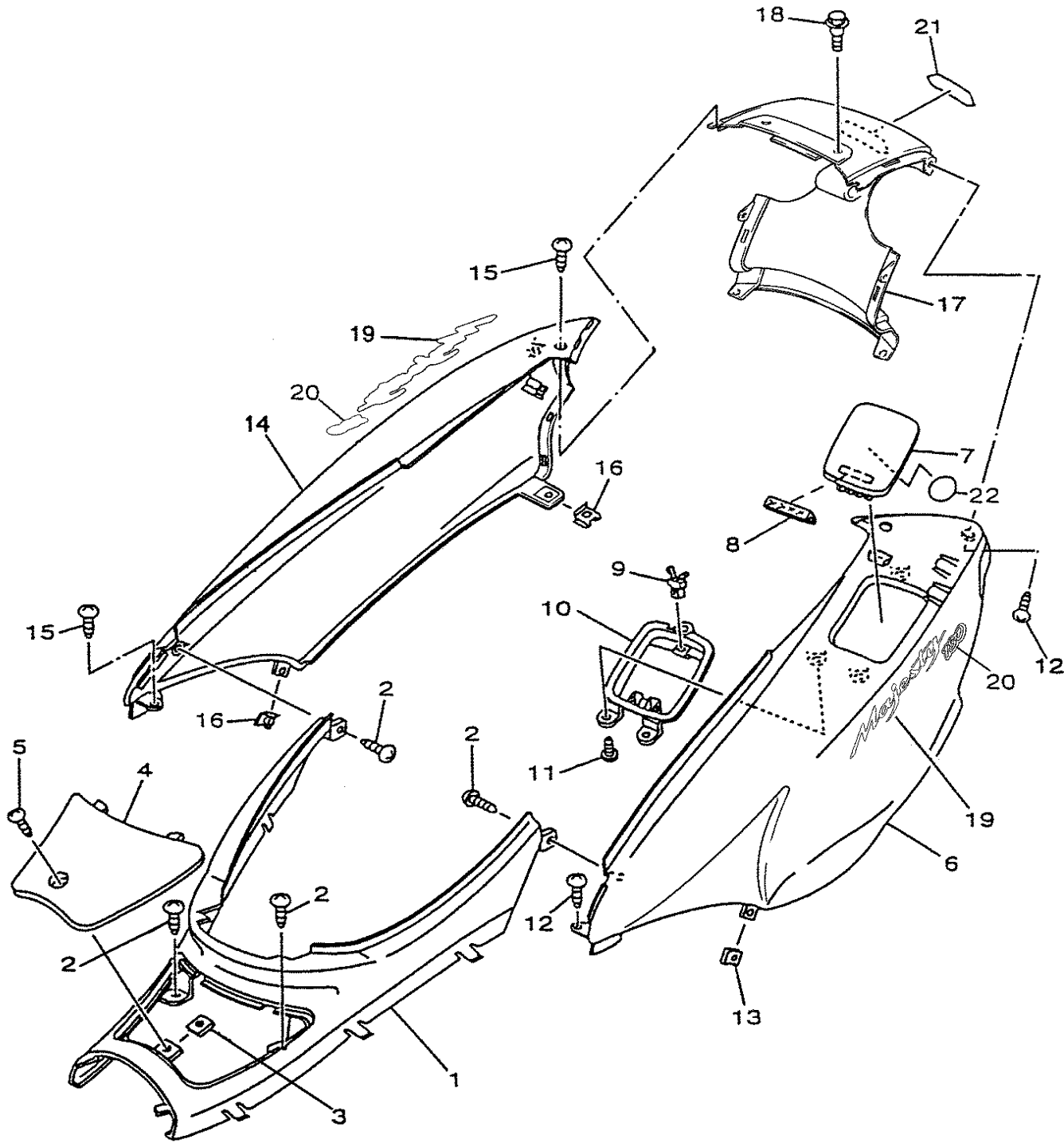


FIG. 17 FENDER

REF. NO.	PART NO.	DESCRIPTION	5XM3				REMARKS
1	5DS-F1511-00-LK	FENDER, FRONT	1				UR FIS
	5DS-F1511-00-P6	FENDER, FRONT	1				UR CST
	5DS-F1511-00-PB	FENDER, FRONT	1				UR DNM8
2	90159-06816	SCREW, WITH WASHER	2				
3	90387-06X05	COLLAR	2				
4	90109-06X05	BOLT	2				
5	5DS-F1552-00	FENDER, INNER	1				
6	9580M-06012	BOLT, FLANGE	1				
7	5DS-F8317-00	NUT, EMBLEM	2				
8	2RN-F1518-00	HOLDER, CABLE	1				
9	5DS-F1521-00	FLAP, FRONT FENDER	1				
10	5NR-F1611-00	FENDER, REAR	1				
11	9890M-06016	SCREW, BIND	2				
12	90387-06X04	COLLAR	1				
13	5DS-F1685-00	BRACKET, LICENSE	1				
14	5DS-F1682-00	STAY, PLATE	1				
15	9850M-06020	SCREW, PAN HEAD	2				
16	9570L-06500	NUT, FLANGE	2				
17	4MJ-H4725-00	WASHER, SPECIAL	2				
18	9580L-06016	BOLT, FLANGE	2				

5XL1300-A170



5XM1300-B180

FIG. 18 SIDE COVER

REF. NO.	PART NO.	DESCRIPTION	5XM3				REMARKS
1	5DS-F1711-10	COVER, SIDE 1	1				UR
2	90167-04X00	SCREW, TAPPING	4				
3	5DS-F8317-00	NUT, EMBLEM	1				
4	5DS-F1716-10	LID, SIDE COVER	1				UR
5	90167-04X00	SCREW, TAPPING	1				
6	5XL-F1721-00-LK	COVER, SIDE 2	1				UR FIS
	5XL-F1721-00-P3	COVER, SIDE 2	1				UR DNM8
	5XL-F1721-00-P6	COVER, SIDE 2	1				UR CST
7	5DS-F177J-00-LK	LID 2	1				UR FIS
	5DS-F177J-00-P6	LID 2	1				UR CST
	5DS-F177J-00-PB	LID 2	1				UR DNM8
8	5DS-F174X-00	DAMPER	1				
9	4HC-24618-00	PLATE, LOCK 3	1				
10	5DS-F178L-00	GUIDE 1	1				
11	90167-04X02	SCREW, TAPPING	3				
12	90167-04X00	SCREW, TAPPING	3				
13	5DS-F8317-00	NUT, EMBLEM	1				
14	5XL-F1731-00-LK	COVER, SIDE 3	1				UR FIS
	5XL-F1731-00-P3	COVER, SIDE 3	1				UR DNM8
	5XL-F1731-00-P6	COVER, SIDE 3	1				UR CST
15	90167-04X00	SCREW, TAPPING	3				
16	5DS-F8317-00	NUT, EMBLEM	1				
17	5NR-F1741-00-LK	COVER, SIDE 4	1				UR FIS
	5NR-F1741-00-P4	COVER, SIDE 4	1				UR DNM8
	5NR-F1741-00-P8	COVER, SIDE 4	1				UR CST
18	90109-06X05	BOLT	2				
19	5XL-F1781-00	EMBLEM 1	2				UR



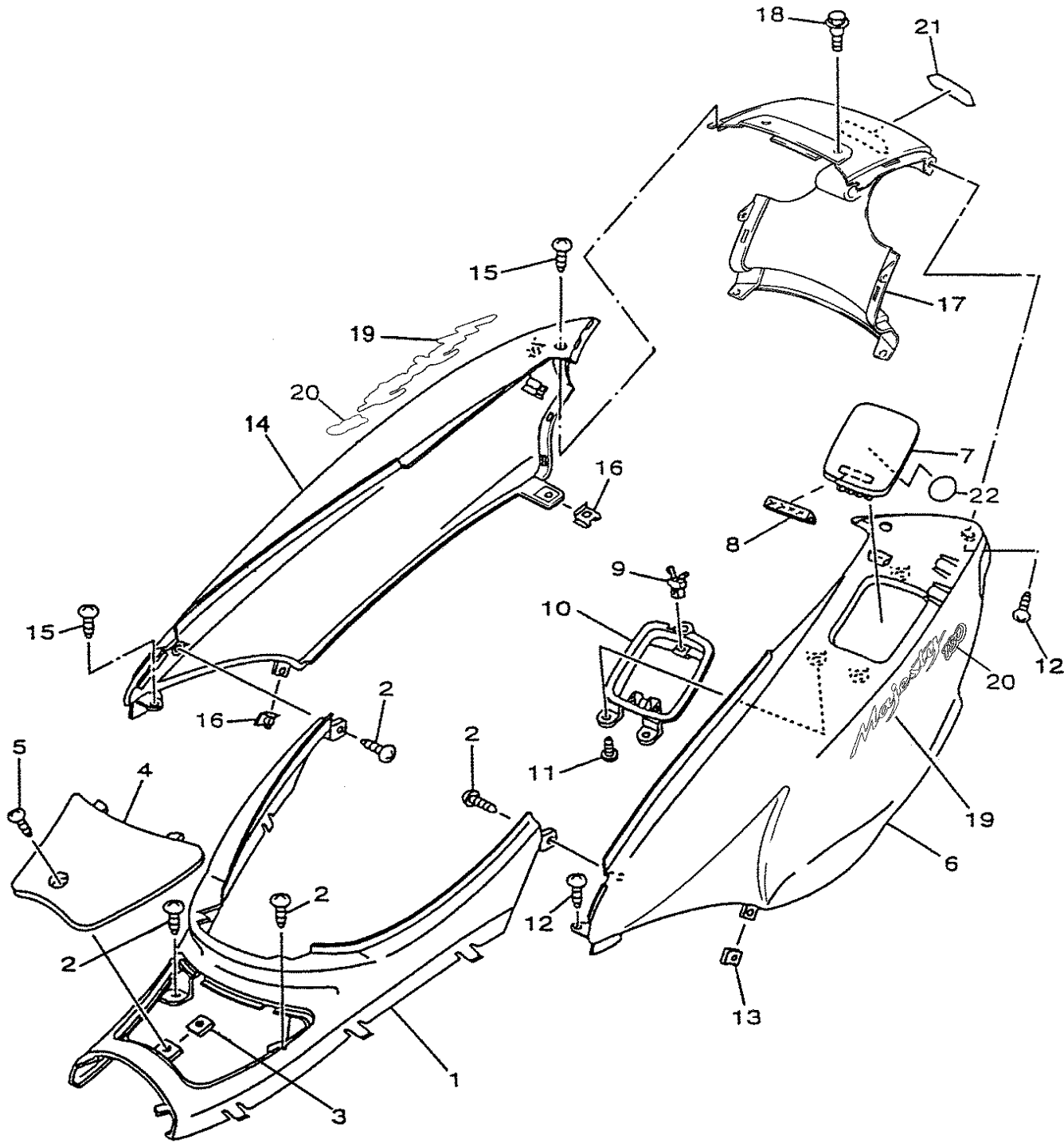


FIG. 18 SIDE COVER

REF. NO.	PART NO.	DESCRIPTION	5XM3				REMARKS
20	5XM-F1781-00	EMBLEM 1	2				UR
21	99236-00080	EMBLEM, YAMAHA	1				UR B
	99237-00080	EMBLEM, YAMAHA	1				UR A, C
22	4SN-F415A-00	LABEL, CAUTION	1				



5XM1300-B180

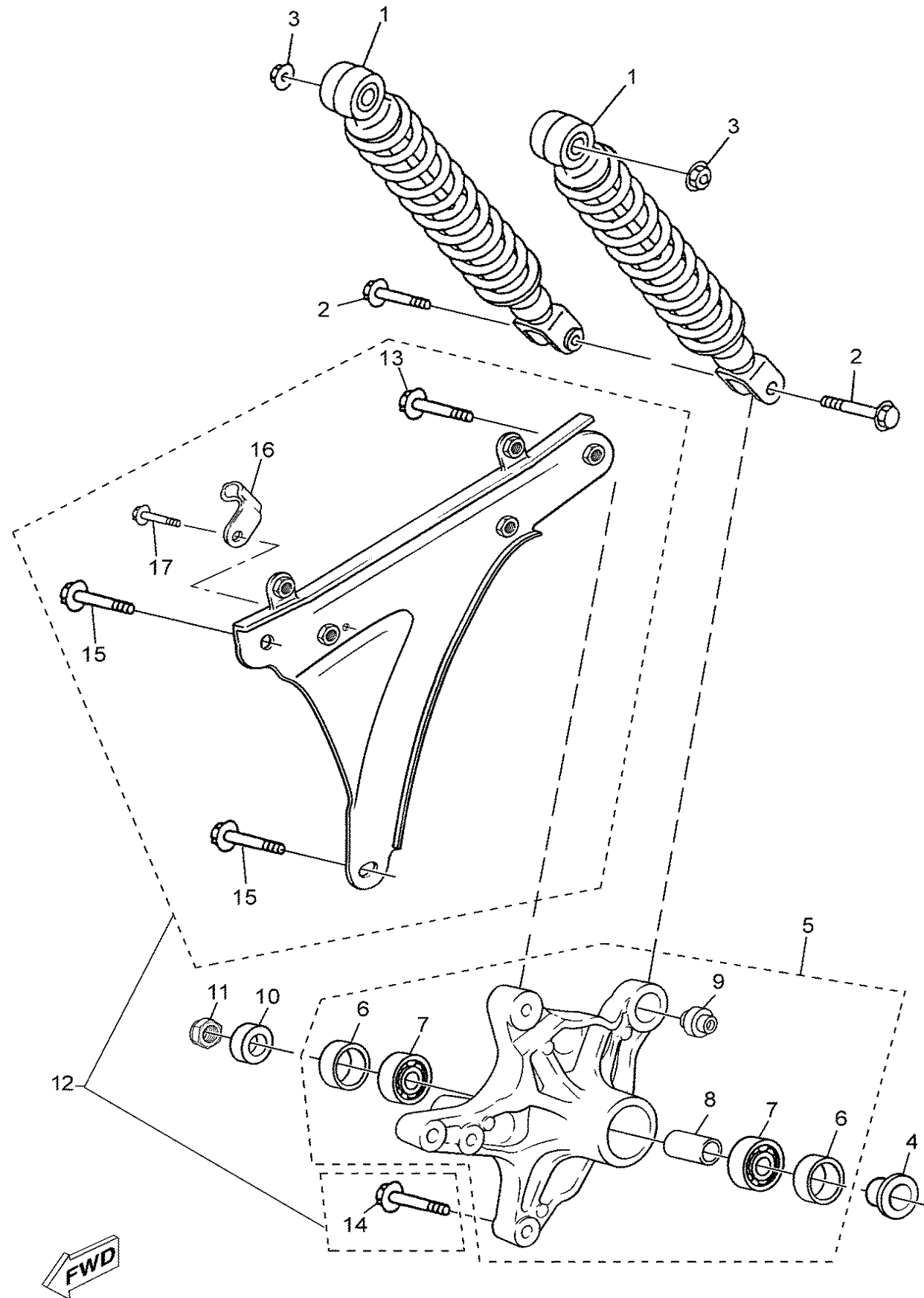
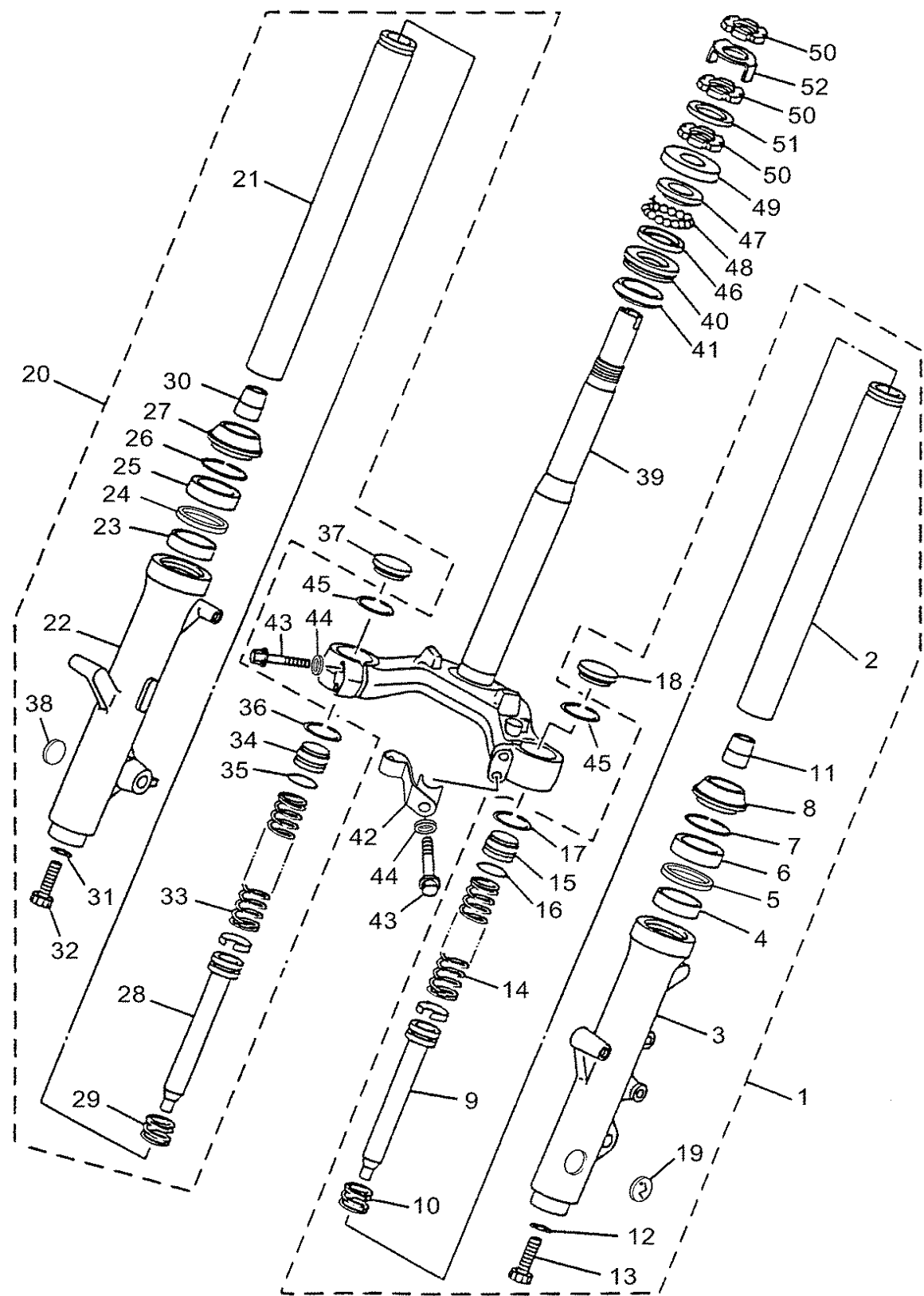


FIG. 19 REAR ARM & SUSPENSION

REF. NO.	PART NO.	DESCRIPTION	5XM3				REMARKS
1	5DS-F2210-00	SHOCK ABSORBER ASSY, REAR	2				UR
2	90105-08121	BOLT, FLANGE	2				
3	90185-10840	NUT, SELF-LOCKING	2				
4	90387-15X00	COLLAR	1				
5	5XM-F5920-00	SUPT. BRKT. ASSY.	1				
6	93106-28824	.OIL SEAL	2				
7	93306-202YR	.BEARING	2				
8	90387-15X02	.COLLAR	1				
9	164-22216-00	.BUSH, REAR SHOCK ABSORBER	1				
10	90387-15X04	COLLAR	1				
11	90185-14815	NUT, SELF-LOCKING	1				
12	5NR-W5371-10	BAR TENSION	1				
13	9751M-08640	BOLT, WITH WASHER	1				
14	9582M-08040	BOLT, FLANGE	1				
15	9582M-08025	BOLT, FLANGE	2				
16	5NR-F587A-00	HOLDER, BREAK HOSE	1				
17	9850M-06016	SCREW, PAN HEAD	1				

5XL3300-C190

FIG. 20 FRONT FORK

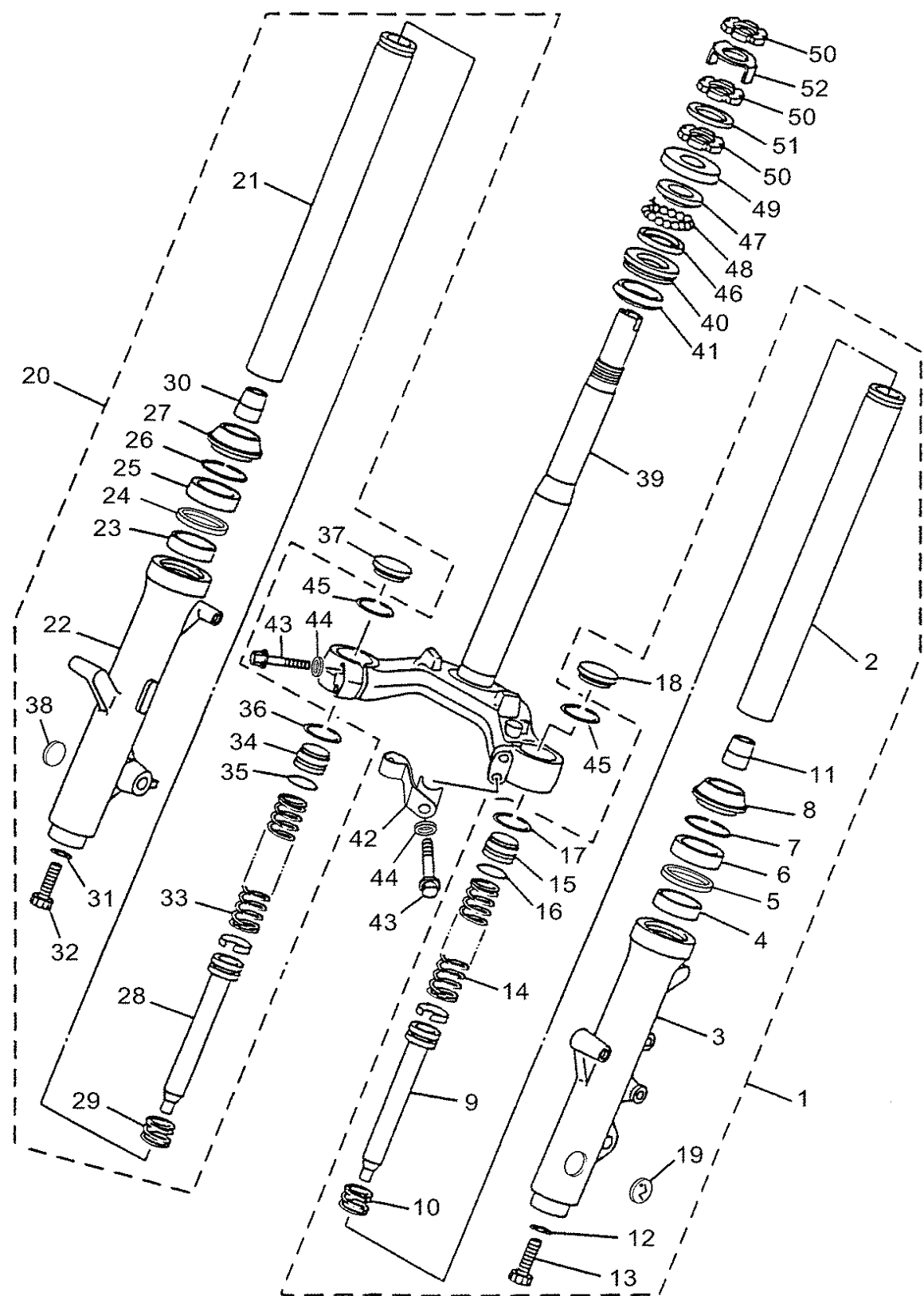


REF. NO.	PART NO.	DESCRIPTION	5XM3				REMARKS
1	5XL-F3102-00	FRONT FORK ASSY (L.H)	1				
2	5DS-F3110-10	.INNER TUBE COMP.1	1				
3	5DS-F3126-10	.TUBE, OUTER (LEFT)	1				
4	5DS-F3125-00	.METAL, SLIDE 1	1				
5	5DS-F3165-20	.WASHER, FELT	1				
6	5DS-F3145-00	.OIL SEAL	1				
7	5DS-F3156-00	.CLIP, OIL SEAL	1				
8	5DS-F3144-00	.SEAL, DUST	1				
9	5XL-F3170-00	.CYLINDER COMP., FRONT FORK	1				
10	5DS-F3151-00	.SPRING, REBOUND	1				
11	5DS-F3173-11	.SPINDLE, TAPER	1				
12	5DS-F3165-10	.WASHER, FELT	1				
13	5DS-F3356-00	.BOLT 2	1				
14	5XL-F3141-00	.SPRING, FRONT FORK	1				
15	5DS-F3111-00	.BOLT, CAP	1				
16	5DS-F3157-00	.RING, PISTON	1				
17	5DS-F3183-00	.CIRCLIP	1				
18	5DS-F3154-00	.PLUG, INNER TUBE	1				
19	5XL-F3108-00	.EMBLEM	1				
20	5XL-F3103-00	FRONT FORK ASSY (R.H)	1				
21	5DS-F3110-10	.INNER TUBE COMP.1	1				
22	5DS-F3136-10	.TUBE, OUTER (RIGHT)	1				
23	5DS-F3125-00	.METAL, SLIDE 1	1				
24	5DS-F3165-20	.WASHER, FELT	1				
25	5DS-F3145-00	.OIL SEAL	1				
26	5DS-F3156-00	.CLIP, OIL SEAL	1				
27	5DS-F3144-00	.SEAL, DUST	1				

5XL1300-A200



FIG. 20 FRONT FORK



REF. NO.	PART NO.	DESCRIPTION	5XM3				REMARKS
28	5XL-F3170-00	.CYLINDER COMP., FRONT FORK	1				
29	5DS-F3151-00	.SPRING, REBOUND	1				
30	5DS-F3173-11	.SPINDLE, TAPER	1				
31	5DS-F3165-10	.WASHER, FELT	1				
32	5DS-F3356-00	.BOLT 2	1				
33	5XL-F3141-00	.SPRING, FRONT FORK	1				
34	5DS-F3111-00	.BOLT, CAP	1				
35	5DS-F3157-00	.RING, PISTON	1				
36	5DS-F3183-00	.CIRCLIP	1				
37	5DS-F3154-00	.PLUG, INNER TUBE	1				
38	5XL-F3108-00	.EMBLEM	1				
39	5DS-W3340-20	UNDER BRACKET COMP.	1				
40	93399-999Y2	.BEARING	1				
41	21L-F3462-00	.SEAL, STEERING	1				
42	5XL-F3317-00	HOLDER, CABLE	1				
43	5DS-F3346-00	BOLT 1	4				
44	5DS-F3165-00	WASHER, FELT	4				
45	5DS-F3153-10	RING, SNAP	2				
46	22F-23412-01	RACE, BALL 2	1				
47	22F-23411-01	RACE, BALL 1	1				
48	22F-2341E-00	RETAINER, BALL BEARING	1				
49	3VP-23416-00	COVER, BALL RACE 2	1				
50	90179-25X00	NUT	3				
51	90202-26X00	WASHER, PLATE	1				
52	5DS-F3418-00	WASHER, SPECIAL	1				



5XL1300-A200

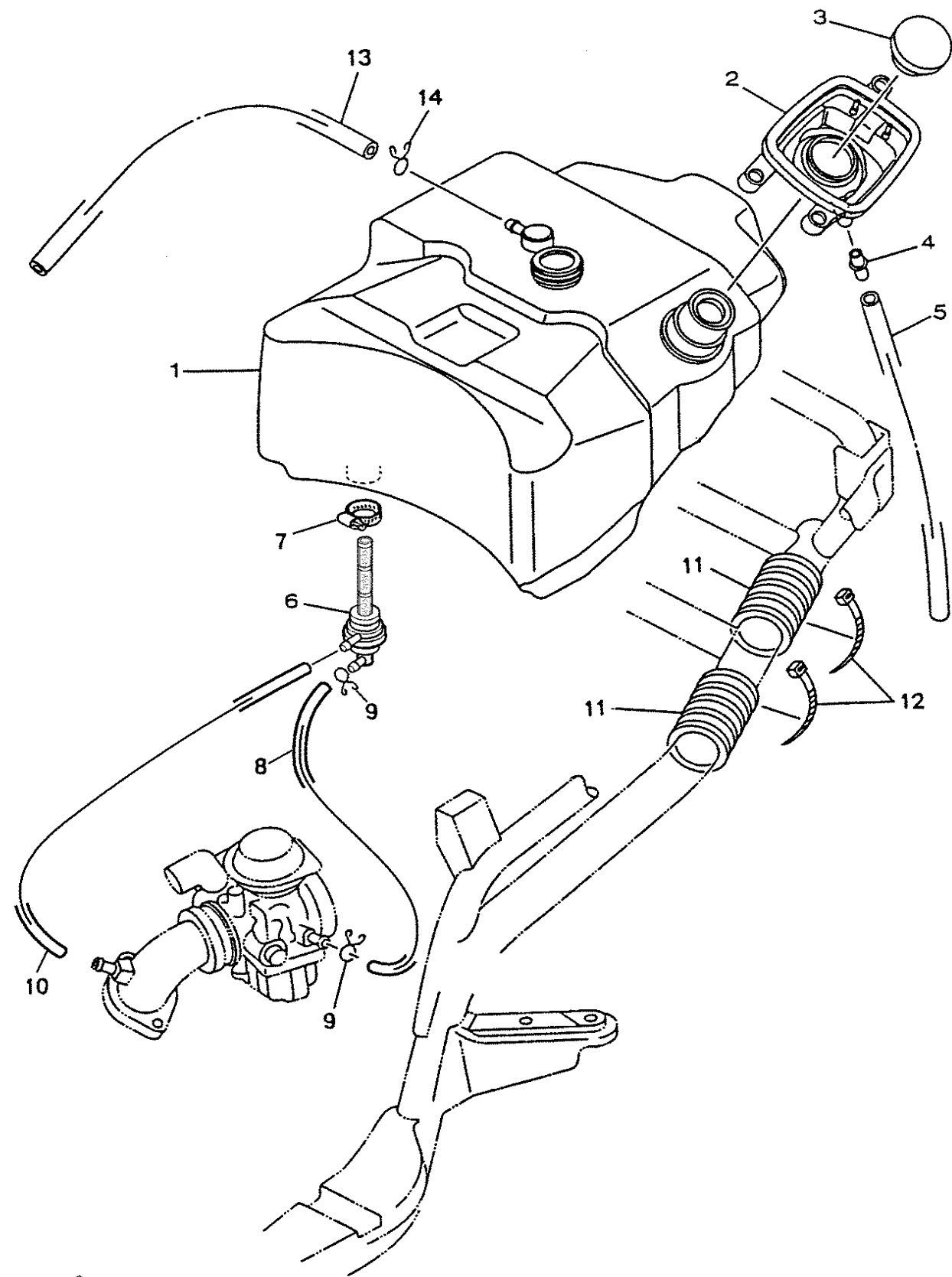


FIG. 21 FUEL TANK

REF. NO.	PART NO.	DESCRIPTION	5XM3				REMARKS
1	5NR-F4110-00	FUEL TANK COMP.	1				
2	5DS-F414A-00	COVER, FILLER	1				
3	5DS-F4610-01	CAP ASSY	1				
4	90387-06X27	COLLAR	1				
5	5DS-F4318-00	PIPE, OVERFLOW	1				
6	5KK-F4500-00	FUEL COCK ASSY 1	1				
7	90450-25823	HOSE CLAMP ASSY	1				
8	5NR-F4311-00	PIPE, FUEL 1	1				
9	90464-50X03	CLAMP	1				
10	5NR-F416A-00	HOSE	1				
11	5DS-F4181-00	DAMPER, LOCATING 1	4				
12	90464-13804	CLAMP	4				
13	5DS-F4313-00	PIPE 3	1				
14	90467-11X01	CLIP	1				



5NR8300-1210

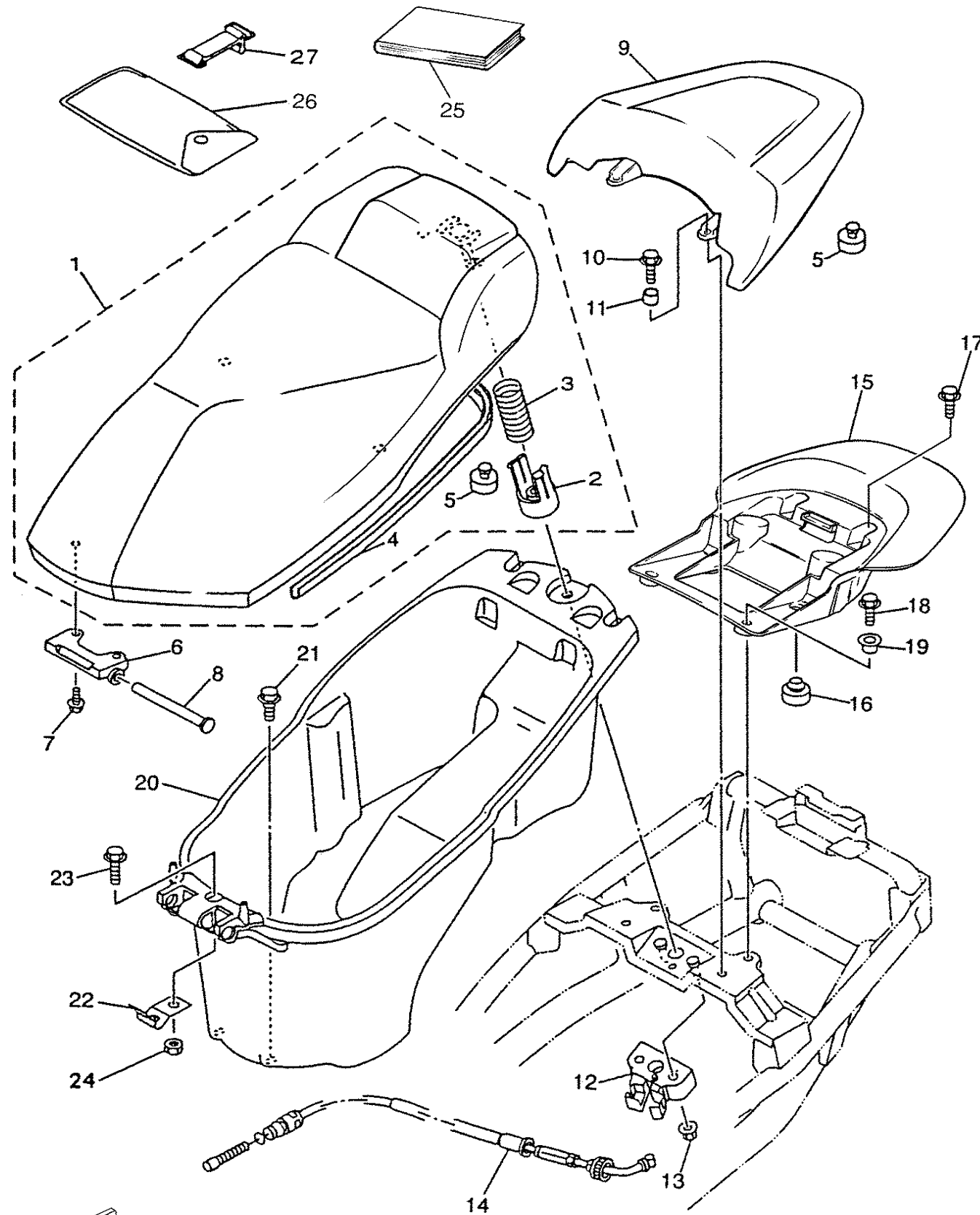


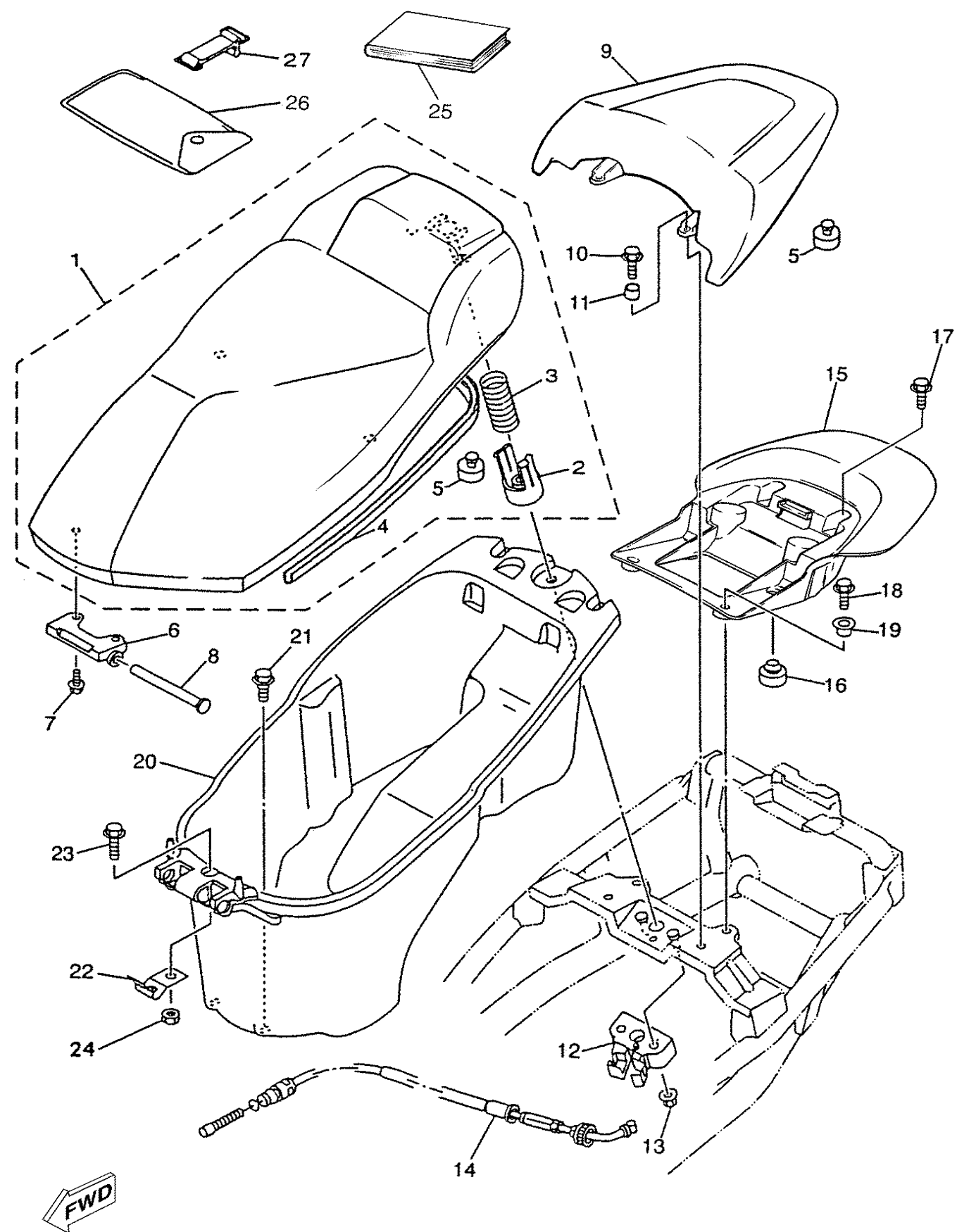
FIG. 22 SEAT

REF. NO.	PART NO.	DESCRIPTION	5XM3				REMARKS
1	5XL-F4710-00	SINGLE SEAT ASSY	1				
2	5DS-F4781-00	.SUPPORT, SPRING 1	1				
3	5DS-F479A-00	.SPRING	1				
4	5DS-F475M-00	.SEAL	1				
5	2RN-F4741-00	.PAD, SEAT	1				
6	5DS-F4726-00	HINGE, SEAT	1				
7	9570N-06500	NUT, FLANGE	2				
8	90241-10015	PIN	1				
9	5XL-F4750-00	TANDEM SEAT ASSY	1				
10	9582N-06020	BOLT, FLANGE	2				
11	90387-06X26	COLLAR	2				
12	5AD-F4780-00	SEAT LOCK ASSY	1				
13	90179-06403	NUT	2				
14	5DS-F478E-00	CABLE, SEAT LOCK	1				
15	5NR-F4773-00-LK	HANDLE, SEAT	1				FIS
	5NR-F4773-00-P4	HANDLE, SEAT	1				DNM8
	5NR-F4773-00-P8	HANDLE, SEAT	1				CST
16	2RN-F4741-00	PAD, SEAT	2				
17	9580M-06016	BOLT, FLANGE	2				
18	9580M-06025	BOLT, FLANGE	2				
19	90201-06815	WASHER, PLATE	2				
20	5XL-F473R-00	BOX 1	1				
21	90109-06X05	BOLT	2				
22	5DS-F4758-00	SPRING	1				
23	9580M-06025	BOLT, FLANGE	1				
24	9570L-06300	NUT, FLANGE	1				
25	5XL-F8199-E1	MANUAL, OWNER'S	1				

5XL1300-A220



FIG. 22 SEAT

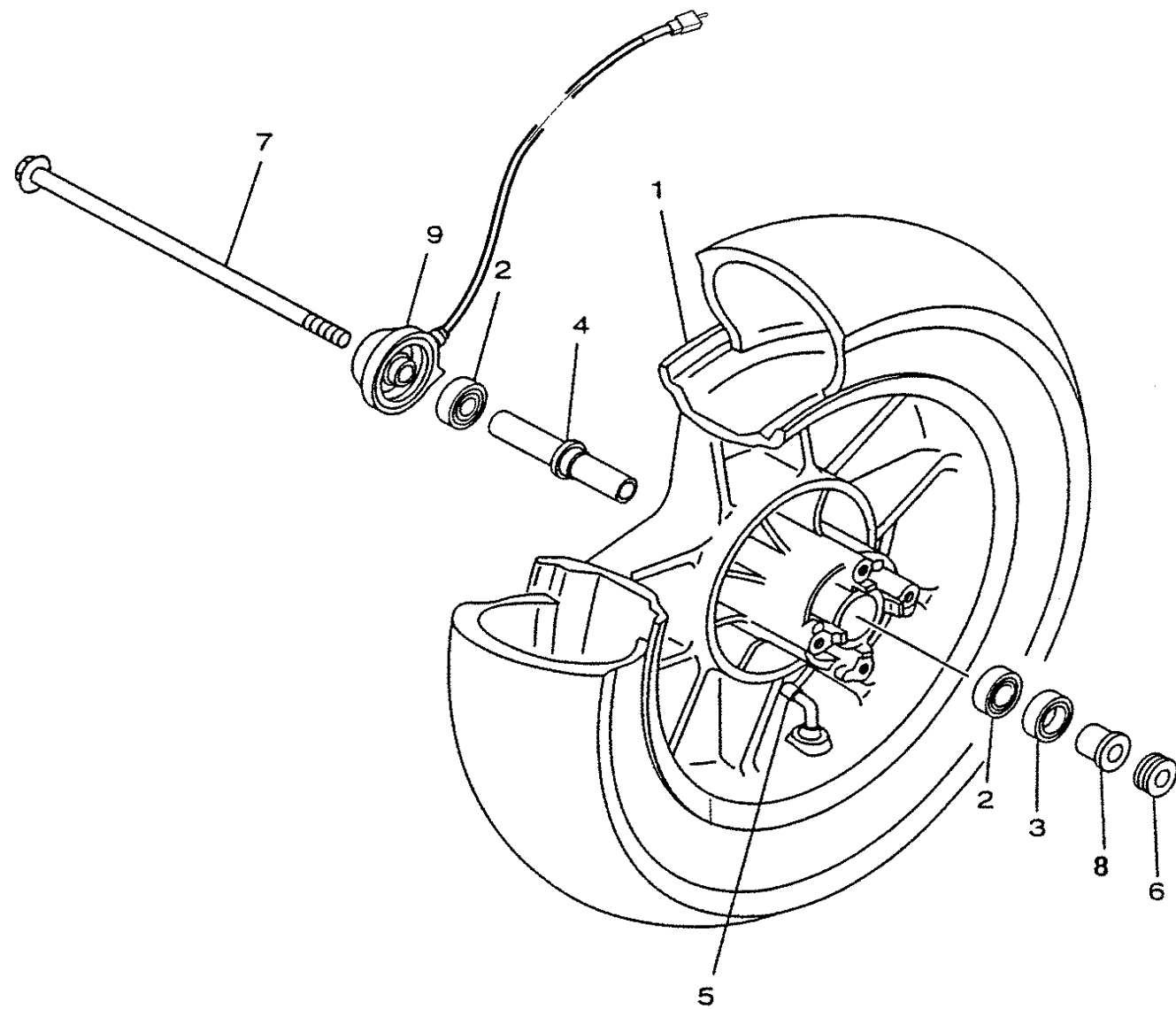


REF. NO.	PART NO.	DESCRIPTION	5XM3				REMARKS
26	5XL-F8100-00	TOOL KIT	1				
27	1TK-H2131-00	BAND, BATTERY	1				

5XL1300-A220

FIG. 23 FRONT WHEEL

REF. NO.	PART NO.	DESCRIPTION	5XM3					REMARKS
1	5DS-F5168-00	CAST WHEEL, FRONT	1					
2	93306-201Y2	BEARING	2					
3	93102-18895	OIL SEAL	1					
4	5DS-F5117-00	SPACER, BEARING	1					
5	3VL-F5170-10	AIR VALVE ASSY	1					
6	95607-12200	NUT, SELF-LOCKING	1					
7	22F-25381-10	AXLE, WHEEL	1					
8	5DS-F5105-00	SPACER	1					
9	5NR-H3756-01	SENSOR, UNIT	1					



5NR8300-1230

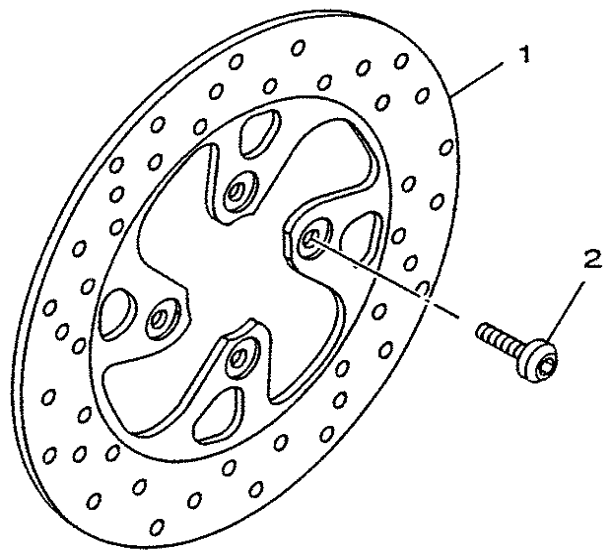
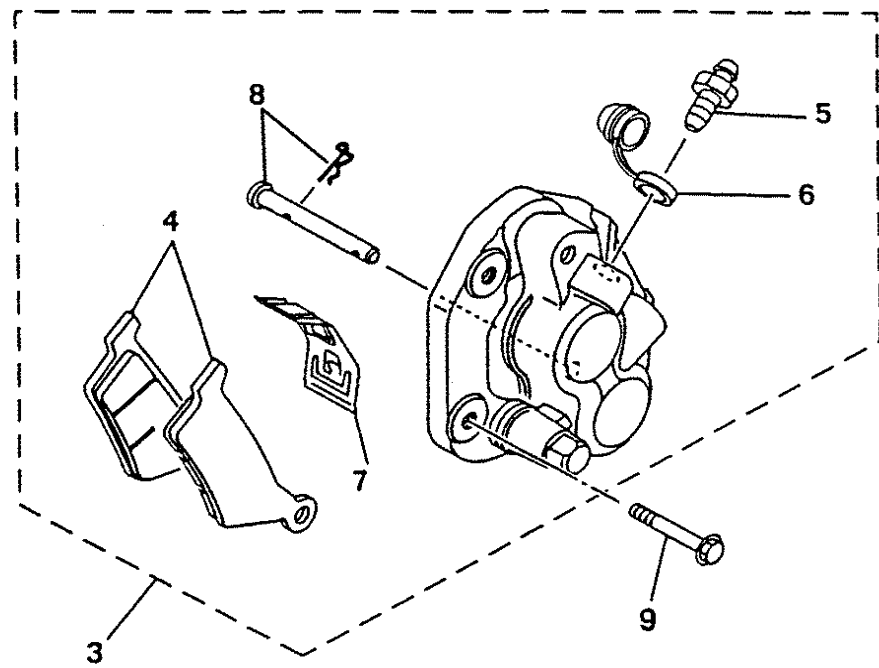


FIG. 24 FRONT BRAKE CALIPER

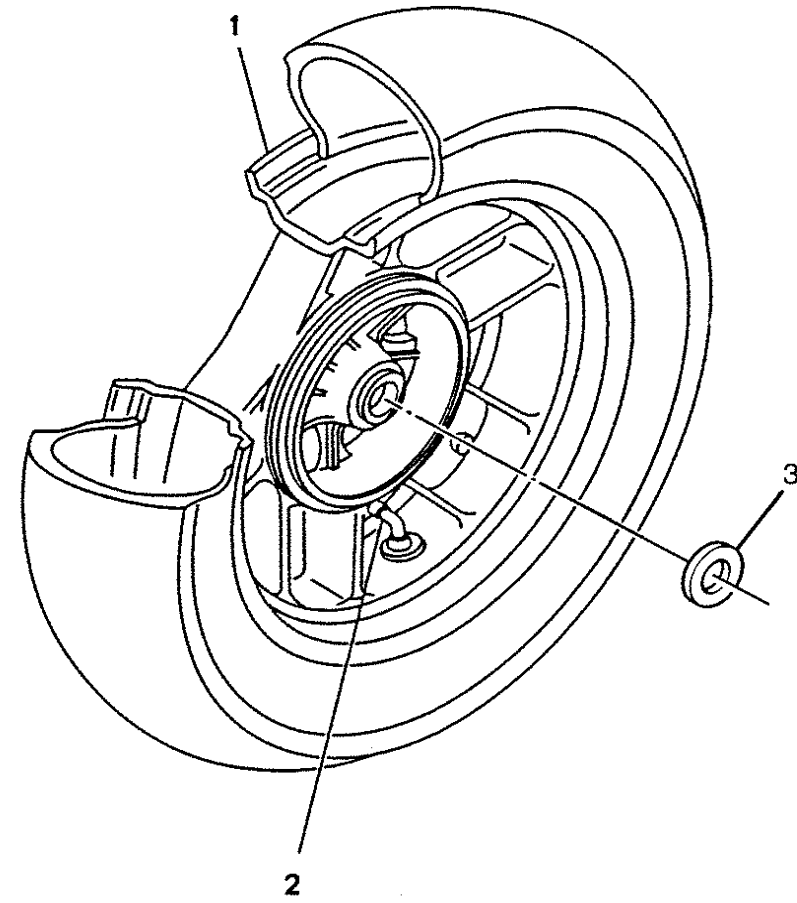
REF. NO.	PART NO.	DESCRIPTION	5XM3					REMARKS
1	5DS-F5831-00	DISC, BRAKE (RIGHT)	1					
2	90149-08814	SCREW	4					
3	5NR-F580T-00	CALIPER ASSY (LEFT)	1					
4	5NR-F5811-00	.PAD, CALIPER 2	2					
5	5DS-F5824-10	.SCREW, BLEED	1					
6	5DS-F5825-00	.CAP	1					
7	5DS-F5919-00	.SUPPORT, PAD	1					
8	5DS-F5924-00	.PIN, PAD	1					
9	9582L-08030	BOLT, FLANGE	2					



5XL1300-A240

FIG. 25 REAR WHEEL

REF. NO.	PART NO.	DESCRIPTION	5XM3					REMARKS
1	5NR-F5338-00	CAST WHEEL, REAR	1					
2	3VL-F5170-10	AIR VALVE ASSY	1					
3	90201-22X00	WASHER, PLATE	1					



5NR8300-1250

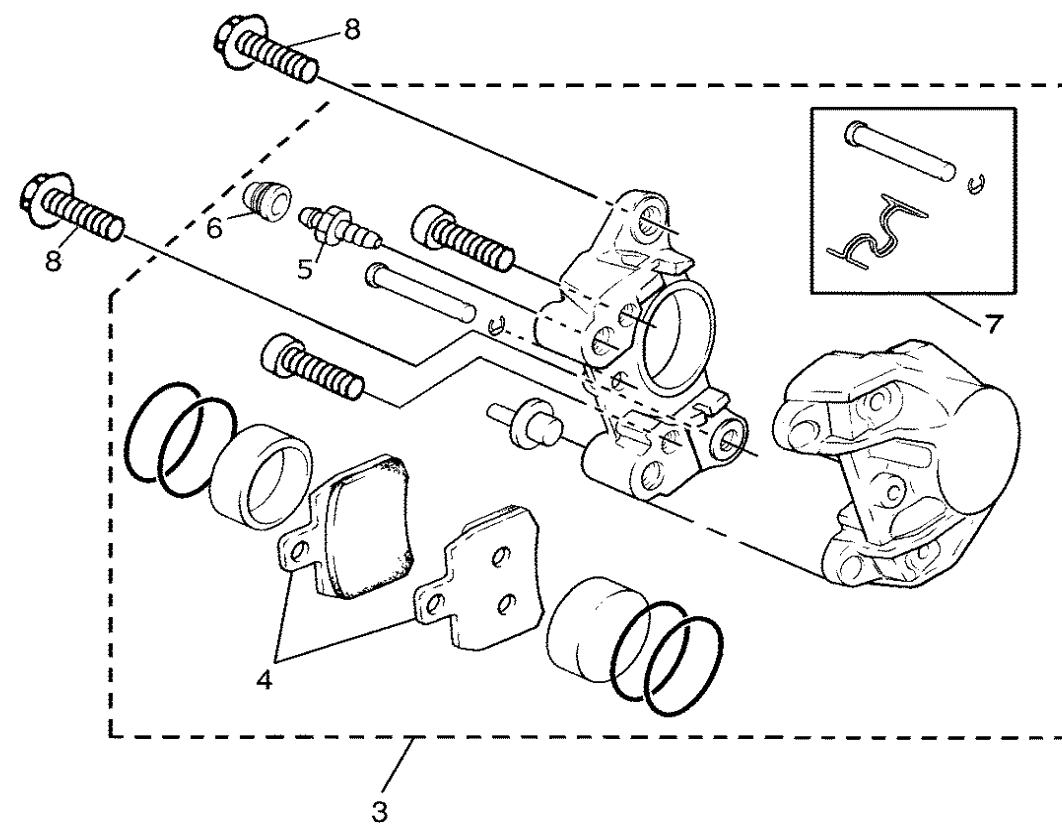
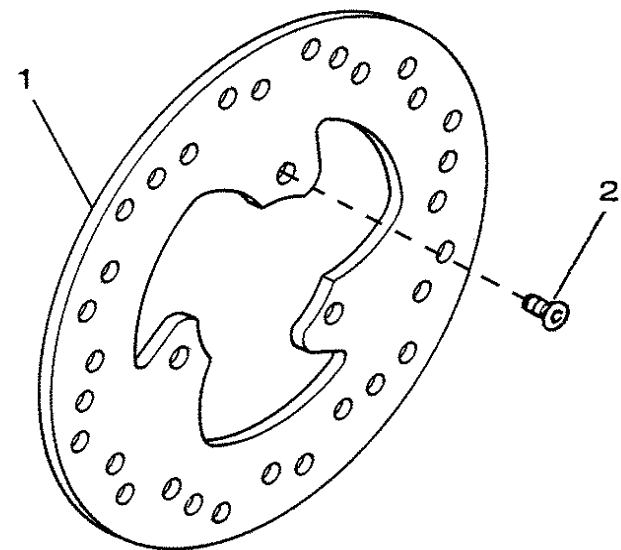


FIG. 26 REAR BRAKE CALIPER

REF. NO.	PART NO.	DESCRIPTION	5XM3					REMARKS
1	5NR-F582W-00	DISK, REAR BRAKE 2	1					
2	90149-08814	SCREW	3					
3	5NR-F580W-00	CALIPER ASSY, REAR 2	1					
4	5NR-F5811-10	.PAD, CALIPER 2	1					
5	5NR-F5824-00	.SCREW, BLEED	1					
6	5NR-F5825-00	.CAP	1					
7	5NR-F5919-00	.SUPPORT, PAD	1					
8	9582M-08040	BOLT, FLANGE	2					



5XL1300-A260

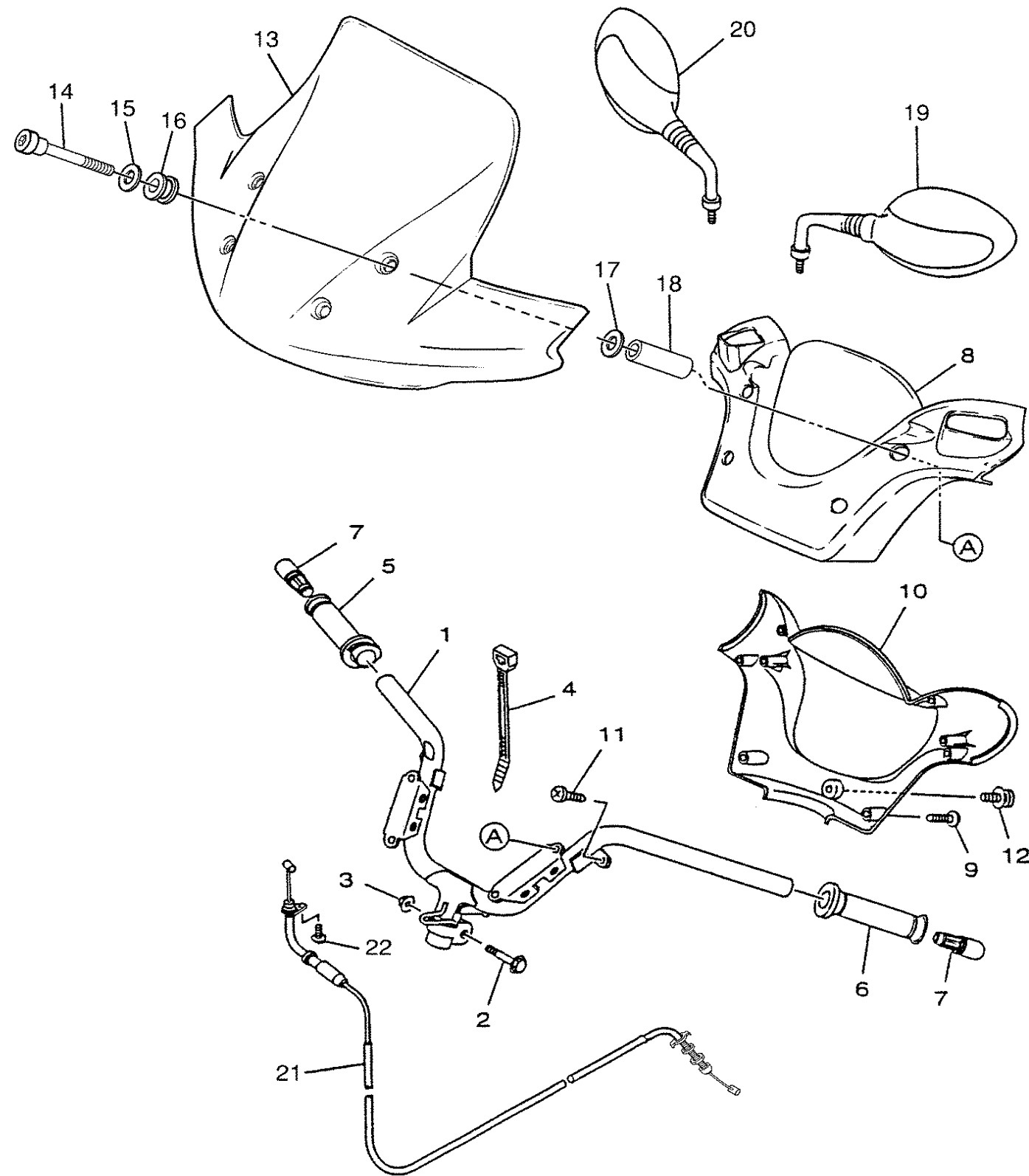


FIG. 27 STEERING HANDLE & CABLE

REF. NO.	PART NO.	DESCRIPTION	5XM3				REMARKS
1	5NR-F6110-00	HANDLE COMP.	1				
2	90105-10036	BOLT, FLANGE	1				
3	90185-10840	NUT, SELF-LOCKING	1				
4	90464-80X00	CLAMP	1				
5	5HT-F6240-00	GRIP ASSY	1				
6	5DS-F6241-00	GRIP	1				
7	5HT-F6246-00	END, GRIP	2				
8	5NR-F6143-00-4B	COVER, HANDLEBAR UPPER 1	1				UR BL2
9	90167-04X00	SCREW, TAPPING	6				
10	5DS-F6145-10	COVER, HANDLEBAR UPPER 2	1				
11	90167-04X00	SCREW, TAPPING	2				
12	90159-06X00	SCREW, WITH WASHER	1				
13	5XL-F6234-00	SCREEN	1				
14	90109-06X06	BOLT	4				
15	90201-10X06	WASHER, PLATE	4				
16	90480-14X00	GROMMET	4				
17	90201-06821	WASHER, PLATE	4				
18	90387-07X01	COLLAR	4				
19	5DS-F6280-00	REAR VIEW MIRROR ASSY (LEFT)	1				
20	5DS-F6290-00	REAR VIEW MIRROR ASSY (RIGHT)	1				
21	5XL-F6311-00	CABLE, THROTTLE 1	1				
22	9850M-05010	SCREW, PAN HEAD	1				



5XL1300-A270

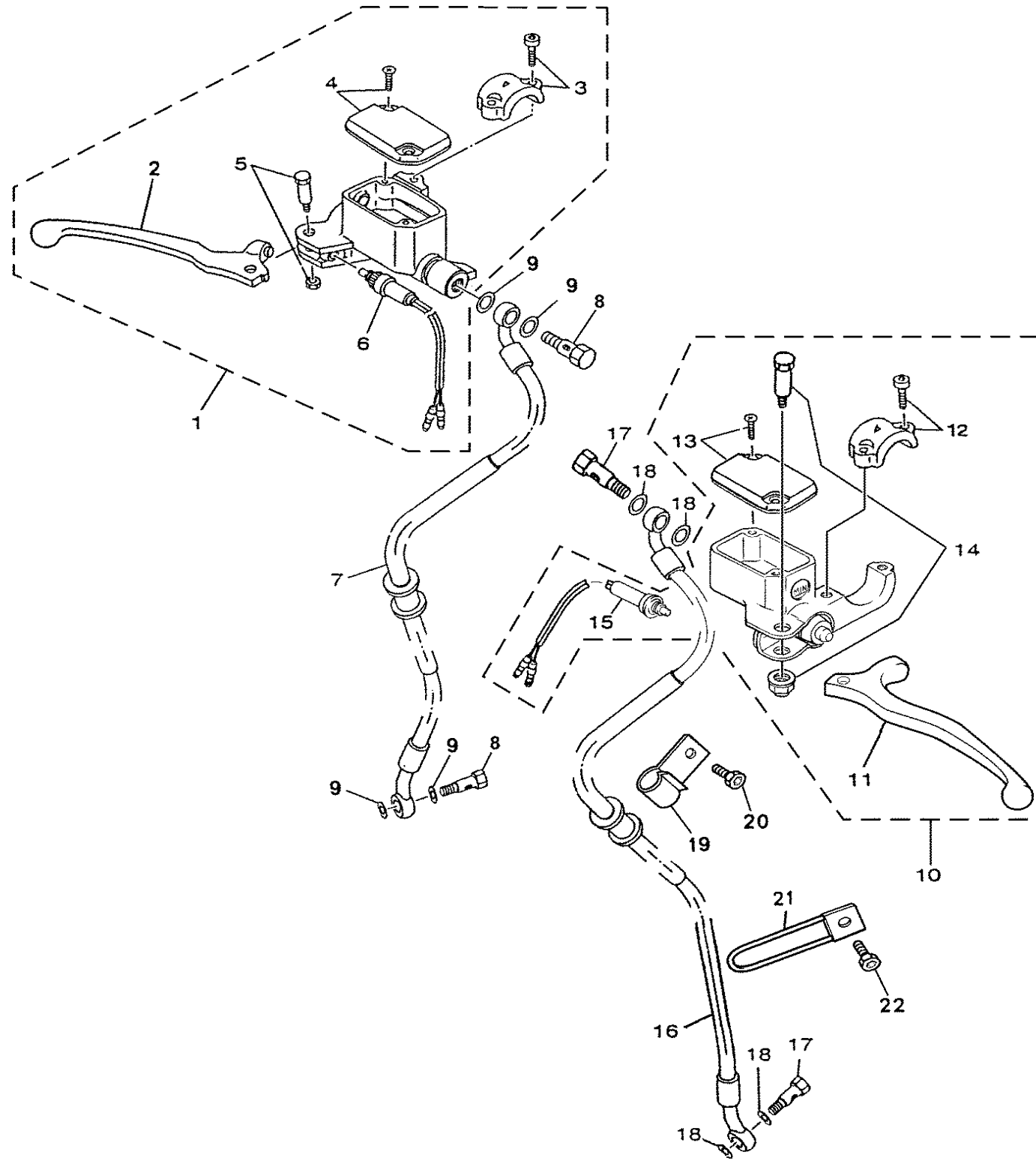


FIG. 28 FRONT MASTER CYLINDER

REF. NO.	PART NO.	DESCRIPTION	5XM3				REMARKS
1	5NR-F583T-01	MASTER CYLINDER ASSY	1				
2	5DS-H3922-01	.LEVER 2	1				
3	4SB-F5867-10	.BRACKET, MASTER CYLINDER	1				
4	5NR-F5852-00	.CAP, RESERVOIR	1				
5	4SB-H3945-00	.BOLT, LEVER	1				
6	5XL-H3980-00	.FRONT STOP SWITCH ASSY	1				
7	5NR-F5872-00	HOSE, BRAKE 1	1				
8	2RN-F5877-00	BOLT, OIL 1	2				
9	90201-10118	WASHER, PLATE	4				
10	5NR-F583V-01	RR. MASTER CYLINDER ASSY.	1				
11	5DS-H3922-01	LEVER 2	1				
12	4SB-F5867-10	BRACKET, MASTER CYLINDER	1				
13	5NR-F5852-00	CAP, RESERVOIR	1				
14	4SB-H3945-00	BOLT, LEVER	1				
15	5XL-H3980-00	FRONT STOP SWITCH ASSY	1				
16	5NR-F5873-00	HOSE, BRAKE 2	1				
17	2RN-F5877-00	BOLT, OIL 1	2				
18	90201-10118	WASHER, PLATE	4				
19	5NR-F5876-10	HOLDER, BRAKE HOSE 2	1				
20	9760L-06216	SCREW, PAN HEAD WITH WASHER	1				
21	5NR-F6132-00	GUIDE, CABLE 2	1				
22	9760L-06216	SCREW, PAN HEAD WITH WASHER	1				
23	90464-50X03	CLAMP	1				



5NR8300-1280

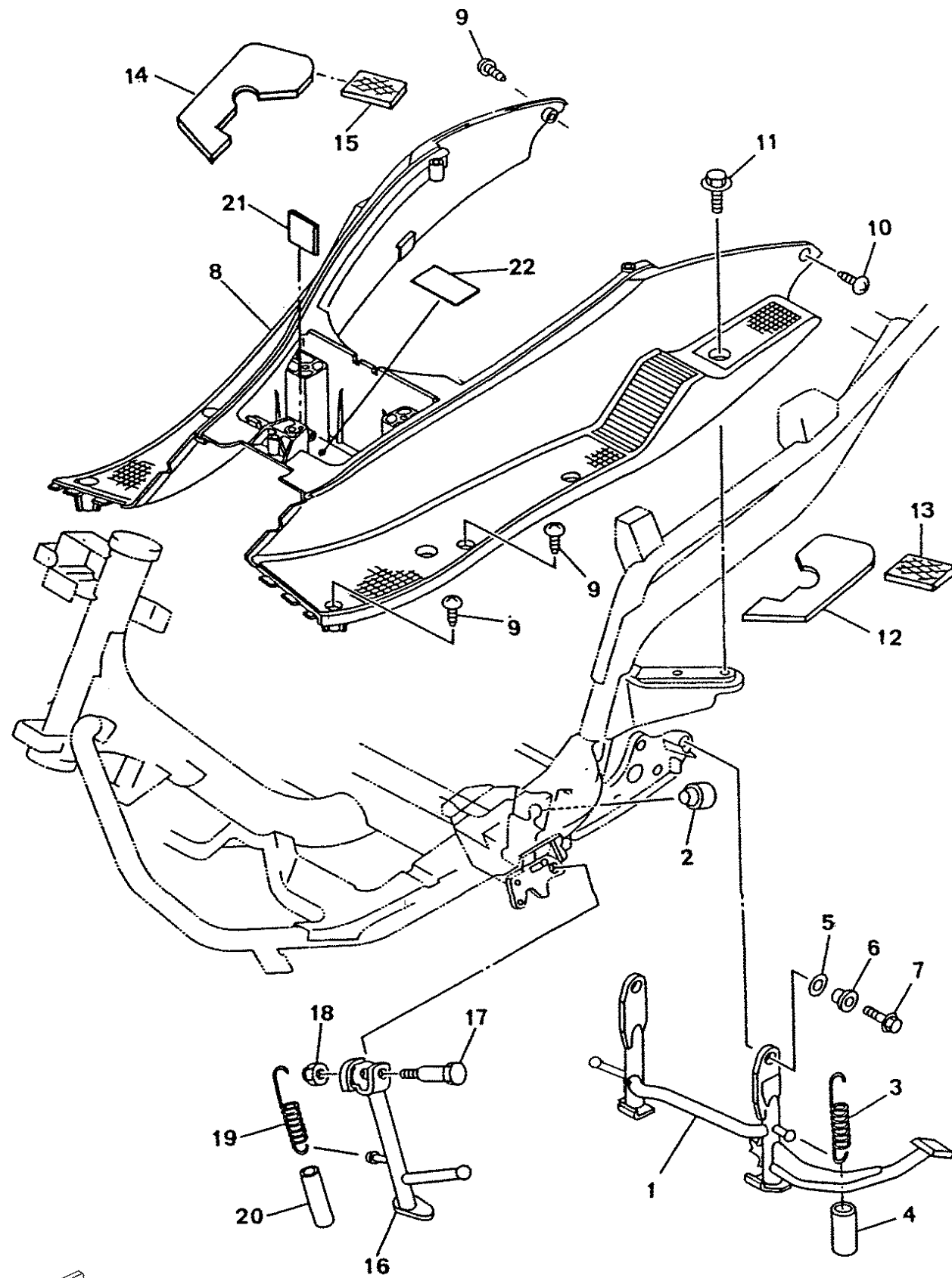
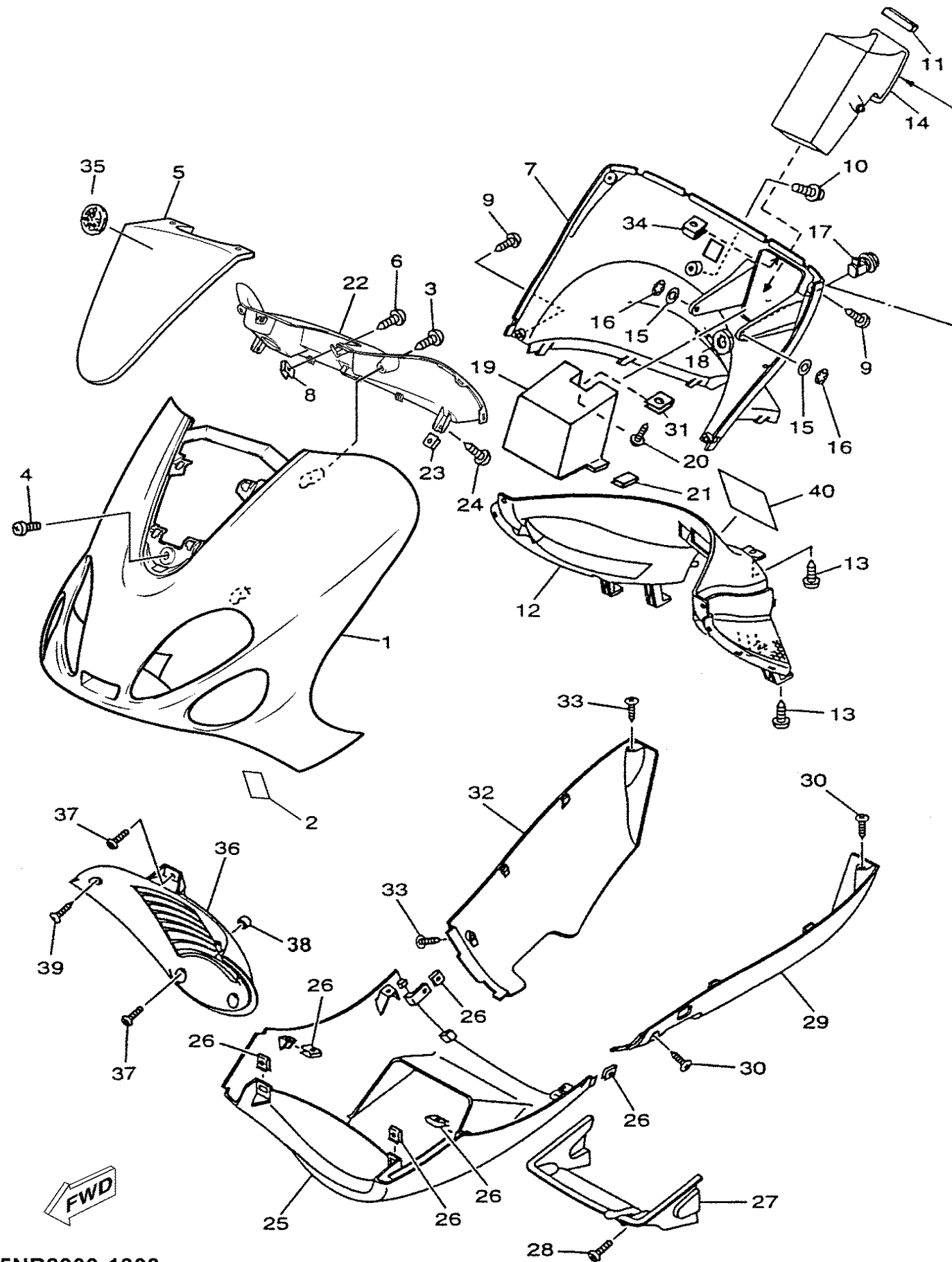


FIG. 29 STAND & FOOTREST

REF. NO.	PART NO.	DESCRIPTION	5XM3				REMARKS
1	5NR-F7111-00	STAND, MAIN	1				
2	2JW-F7114-10	STOPPER, MAIN STAND	1				
3	90506-34X00	SPRING, TENSION	1				
4	5DS-F7244-00	COVER	1				
5	90202-15X00	WASHER, PLATE	2				
6	5DS-F7113-01	COLLAR, MAIN STAND	2				
7	9582L-10035	BOLT, FLANGE	2				
8	5XL-F7481-00	BOARD, FOOTREST	1				
9	90167-04X00	SCREW, TAPPING	7				
10	90167-04X02	SCREW, TAPPING	1				
11	90119-06118	BOLT, WITH WASHER	4				
12	5DS-F7445-00	PLATE 1	1				
13	5DS-F7414-00	DAMPER, FOOTREST	1				
14	5DS-F7446-00	PLATE 2	1				
15	5DS-F7414-00	DAMPER, FOOTREST	1				
16	5DS-F7311-00	STAND, SIDE	1				
17	90109-100E8	BOLT	1				
18	90185-10037	NUT, SELF-LOCKING	1				
19	90506-26X00	SPRING, TENSION	1				
20	5DS-F7351-00	GUIDE, SIDE STAND	1				
21	4MJ-F4183-00	DAMPER, LOCATING 3	1				
22	5DS-H2178-01	LABEL, FUSE	1				

5XL1300-A290



5NR8300-1300

FIG. 30 COWLING 1

REF. NO.	PART NO.	DESCRIPTION	5XM3				REMARKS
1	5NR-F8311-00-LK	LEG SHIELD 1	1				UR FIS
	5NR-F8311-00-P4	LEG SHIELD 1	1				UR DNM8
	5NR-F8311-00-P8	LEG SHIELD 1	1				UR CST
2	90167-04X00	SCREW, TAPPING	2				
3	9580L-06012	BOLT, FLANGE	1				
4	90109-06X05	BOLT	1				
5	5NR-F835U-00-LK	PANEL 1	1				UR FIS
	5NR-F835U-00-P4	PANEL 1	1				UR DNM8
	5NR-F835U-00-P8	PANEL 1	1				UR CST
6	90167-04X00	SCREW, TAPPING	2				
7	5XL-F831A-10	BODY, COWLING	1				
8	5DS-F8317-00	NUT, EMBLEM	1				
9	90167-04X00	SCREW, TAPPING	5				
10	90159-06X00	SCREW, WITH WASHER	1				
11	5DS-F8371-00	DAMPER	1				
12	5DS-F8312-00	LEG SHIELD 2	1				
13	90167-04X00	SCREW, TAPPING	5				
14	5DS-F839L-11	LID 2	1				
15	9290L-05200	WASHER	2				
16	90183-05813	NUT, SPRING	2				
17	4MJ-F1780-01	LOCK ASSY	1				
18	4MJ-F1791-00	NUT	1				
19	5DS-F839K-00	LID 1	1				
20	90167-04X00	SCREW, TAPPING	1				
21	90465-05X00	CLAMP	2				
22	5NR-F837L-10	PANEL, CONSOLE 1	1				
23	5DS-F8317-00	NUT, EMBLEM	1				



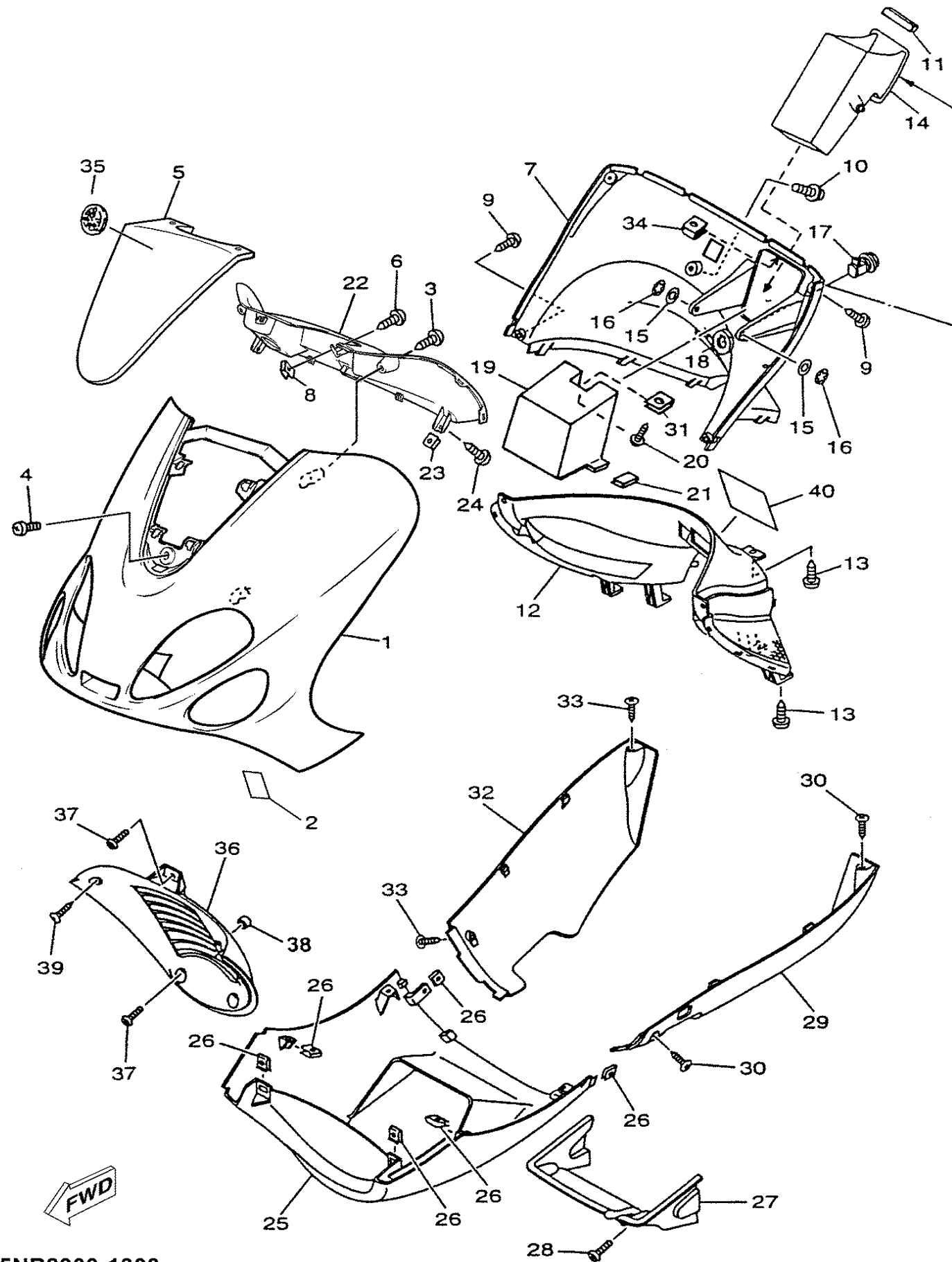


FIG. 30 COWLING 1

REF. NO.	PART NO.	DESCRIPTION	5XM3				REMARKS
24	90167-04X00	SCREW, TAPPING	2				
25	5DS-F8385-01-LK	COVER, LOWER	1				UR FIS
	5DS-F8385-01-P6	COVER, LOWER	1				UR CST
	5DS-F8385-01-PB	COVER, LOWER	1				UR DNM8
26	5DS-F8317-00	NUT, EMBLEM	1				
27	5DS-F8343-00	GUARD, STONE	1				
28	9890M-06016	SCREW, BIND	2				
29	5XL-F171L-00-LK	MOLE, SIDE COVER 1	1				UR FIS
	5XL-F171L-00-P3	MOLE, SIDE COVER 1	1				UR DNM8
	5XL-F171L-00-P6	MOLE, SIDE COVER 1	1				UR CST
30	90167-04X00	SCREW, TAPPING	2				
31	5DS-F8317-00	NUT, EMBLEM	1				
32	5DS-F171M-01-LK	MOLE, SIDE COVER 2	1				UR FIS
	5DS-F171M-01-P6	MOLE, SIDE COVER 2	1				UR CST
	5DS-F171M-01-PB	MOLE, SIDE COVER 2	1				UR DNM8
33	90167-04X00	SCREW, TAPPING	2				
34	5DS-F8317-00	NUT, EMBLEM	1				
35	5DS-F8368-00	EMBLEM	1				
36	5DS-F837N-00	GRILL, AIR INTAKE 1	1				
37	9890M-06016	SCREW, BIND	3				
38	90387-06X06	COLLAR	2				
39	90167-04X00	SCREW, TAPPING	2				
40	5DS-F415E-10	LABEL, CAUTION	1				

5NR8300-1300

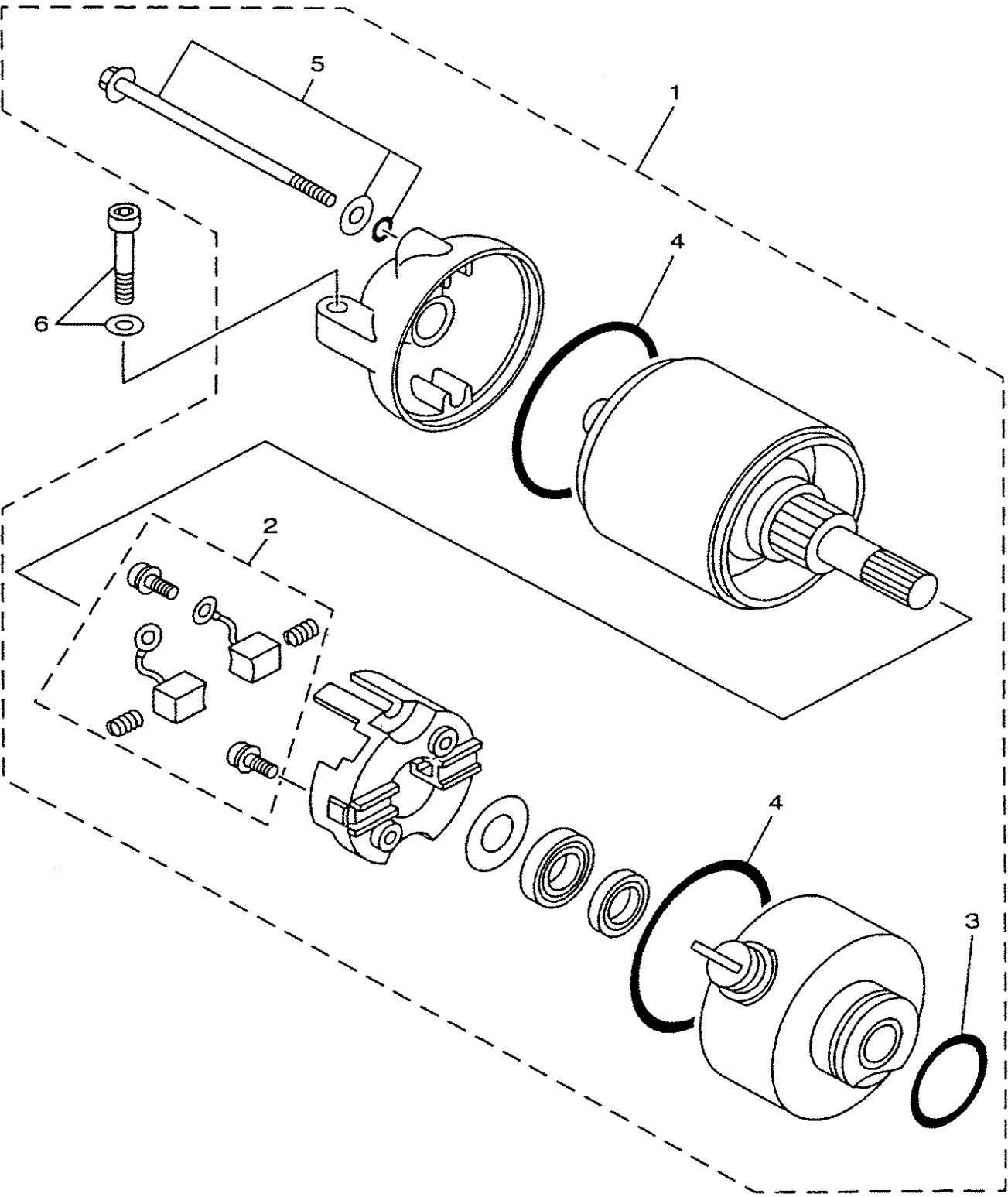


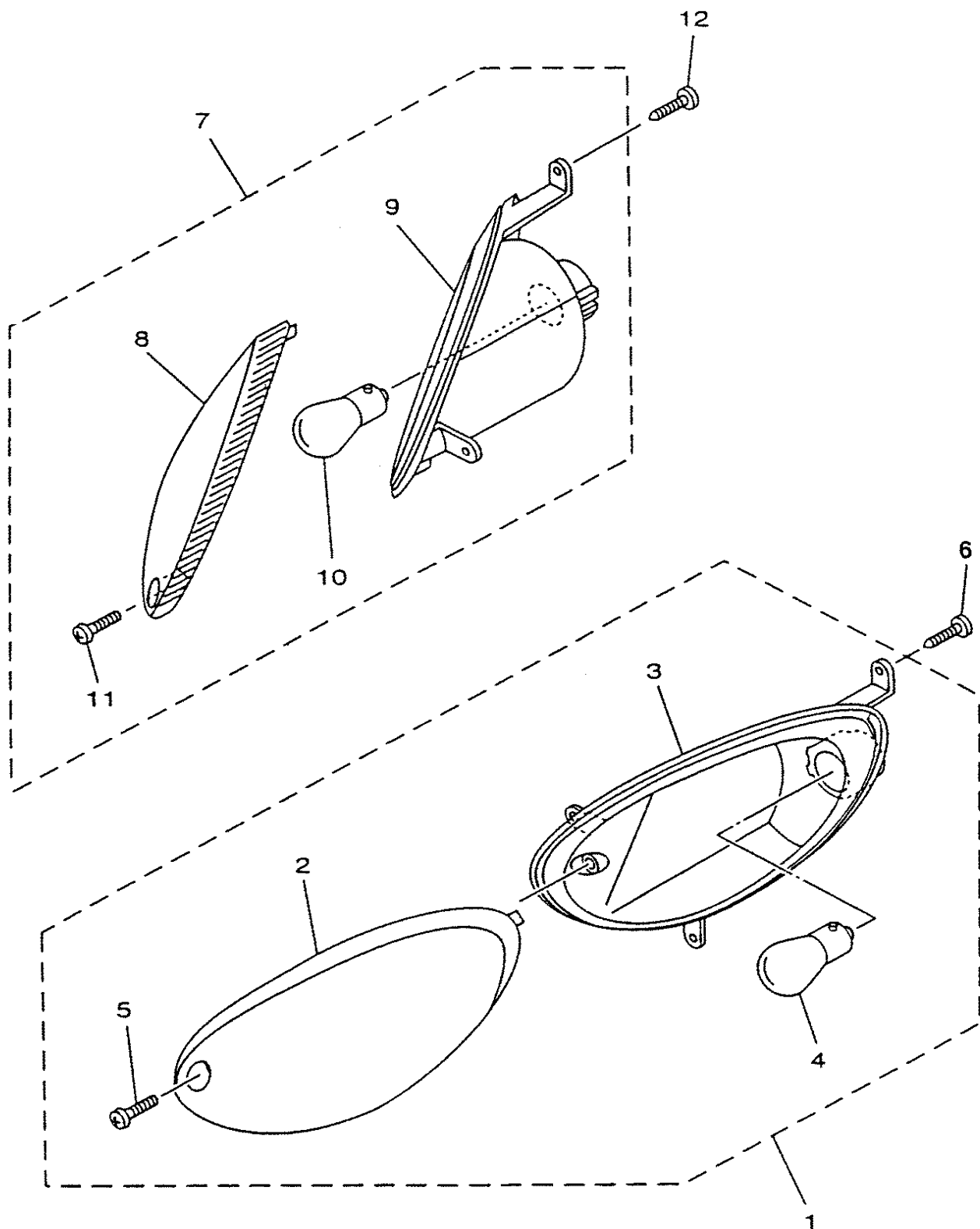
FIG. 32 STARTING MOTOR

REF. NO.	PART NO.	DESCRIPTION	5XM3				REMARKS
1	5DS-H1800-00	STARTING MOTOR ASSY	1				
2	5DS-81801-00	.BRUSH SET	1				
3	93210-25711	.O-RING	1				
4	93210-55699	.O-RING	2				
5	50M-81828-M0	.BOLT 2	1				
6	90110-06X02	BOLT, HEXAGON SOCKET HEAD	2				



FIG. 33 FLASHER LIGHT

REF. NO.	PART NO.	DESCRIPTION	5XM3				REMARKS
1	5XL-H3310-00	FRONT FLASHER LIGHT ASSY 1	1				
2	5XL-H3312-00	.LENS, FLASHER	1				
3	5XL-H3314-00	.BASE, FLASHER 1	1				
4	5XL-H3311-00	.BULB, FLASHER	1				
5	5AD-H3333-00	.SCREW, LENS FITTING	1				
6	90167-04X00	SCREW, TAPPING	3				
7	5XL-H3320-00	FRONT FLASHER LIGHT ASSY 2	1				
8	5XL-H3322-00	.LENS, FLASHER 2	1				
9	5XL-H3324-00	.BASE, FLASHER 2	1				
10	5XL-H3311-00	.BULB, FLASHER	1				
11	5AD-H3333-00	.SCREW, LENS FITTING	1				
12	90167-04X00	SCREW, TAPPING	3				



5NR8300-1330

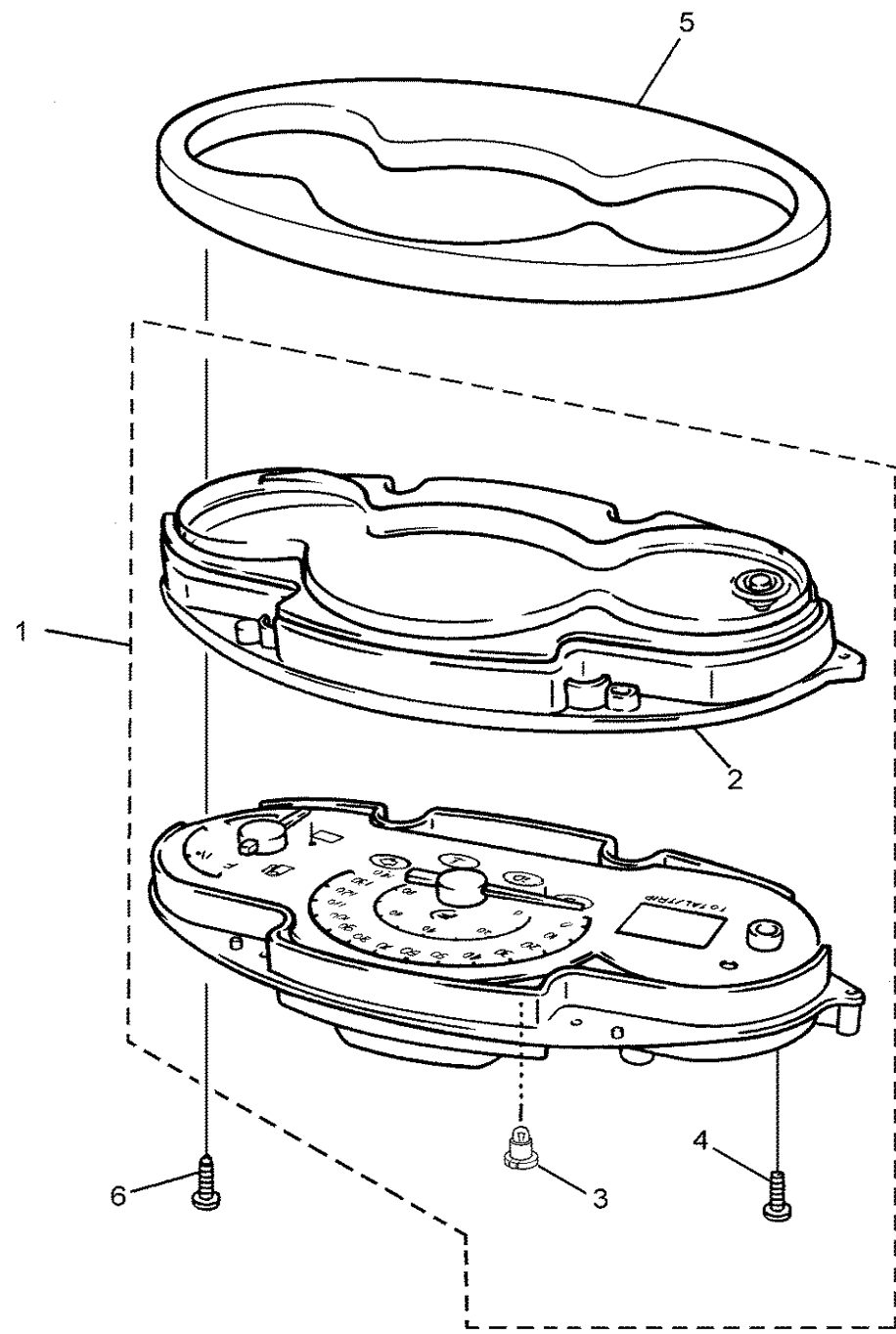


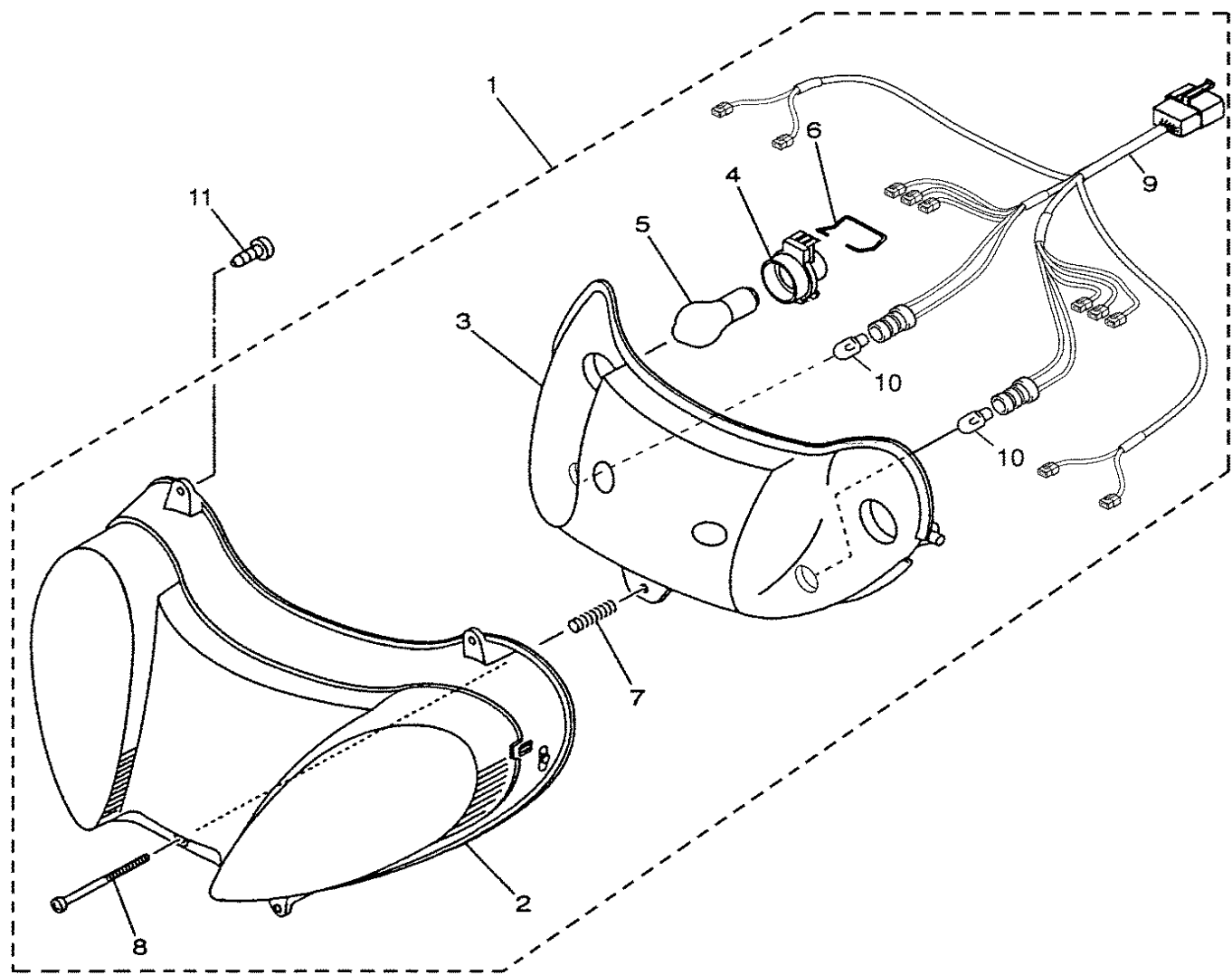
FIG. 34 METER

REF. NO.	PART NO.	DESCRIPTION	5XM3					REMARKS
1	5XL-H3510-00	SPEEDOMETER ASSY	1					
2	5XL-H3511-00	.LENS, SPEEDOMETER	1					
3	5XL-H3517-00	.BULB	3					
4	97707-30514	.SCREW, TAPPING	8					
5	5XL-H3507-00	COVER, SPEEDOMETER	1					UR
6	90167-03X03	SCREW, TAPPING	4					



5XL1300-A340

FIG. 35 HEADLIGHT



REF. NO.	PART NO.	DESCRIPTION	5XM3				REMARKS
1	5NR-H4310-00	HEADLIGHT UNIT ASSY	1				
2	5DS-H4103-00	.HEADLIGHT UNIT ASSY	1				
3	5NR-H4323-00	.REFLECTOR	1				
4	5DU-H4112-00	.SOCKET	2				
5	5AD-H4314-00	.BULB 12V-25/25W	2				
6	3WG-H4324-00	.SPRING, REFLECTOR	2				
7	5AD-H4332-00	.SPRING, SCREW	1				
8	90157-04X02	.SCREW, PAN HEAD	1				
9	5NR-H4340-00	.SOCKET CORD ASSY 1	1				
10	5DS-H4744-00	.BULB (12V-5W)	2				
11	90167-04X00	SCREW, TAPPING	4				



5NR8300-1350

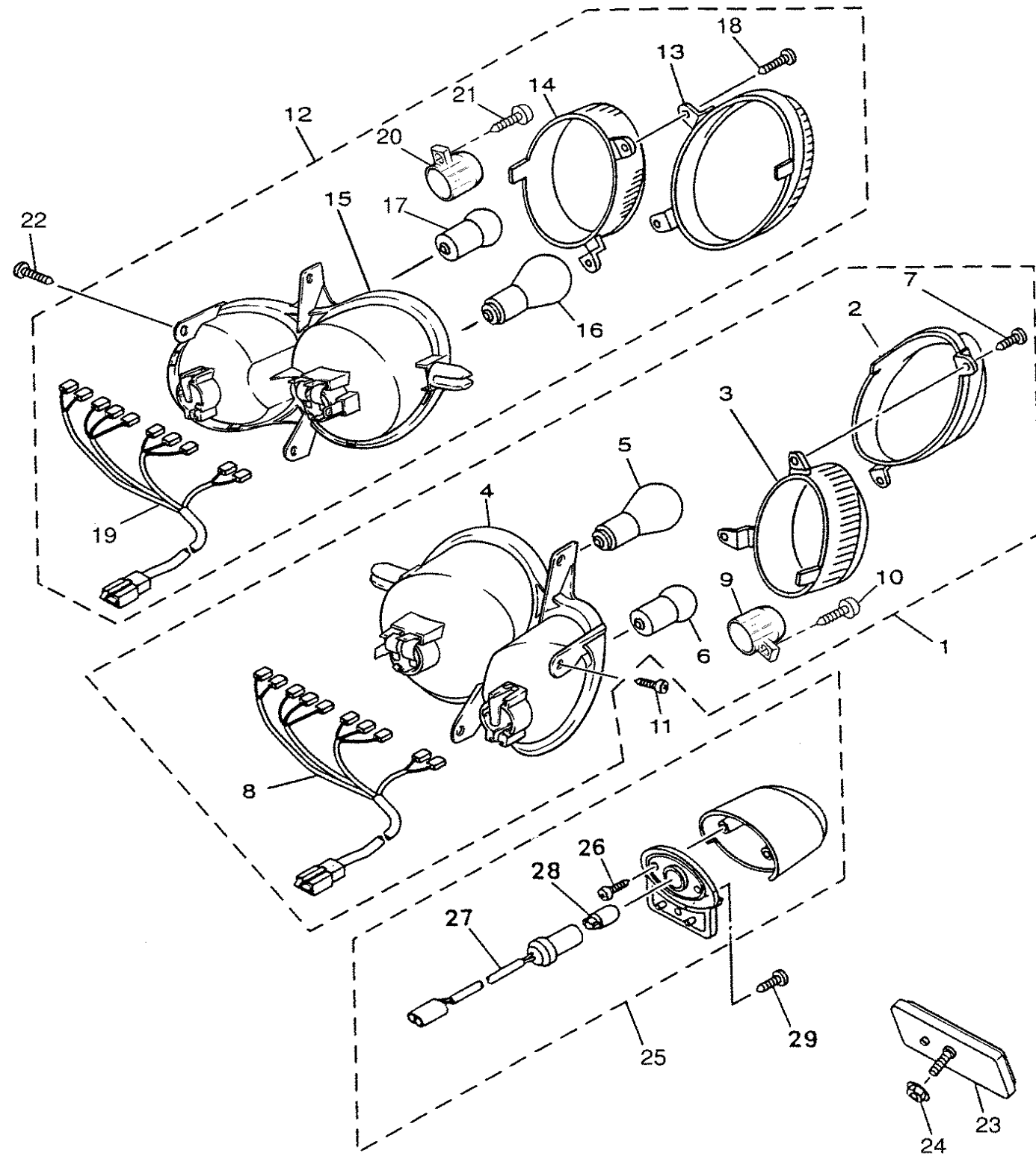


FIG. 36 TAILLIGHT

REF. NO.	PART NO.	DESCRIPTION	5XM3				REMARKS
1	5XL-H4710-00	TAILLIGHT UNIT ASSY	1				
2	5NR-H4721-00	.LENS, TAILLIGHT	1				
3	5XL-H3332-00	.LENS, FLASHER	1				
4	5XL-H4711-00	.BASE, TAILLIGHT	1				
5	4BA-H4714-00	.BULB	1				
6	3TH-H3311-00	.BULB, FLASHER	1				
7	5AD-H3333-00	.SCREW, LENS FITTING	2				
8	5NR-H4533-00	.CORD, TAILLIGHT A	1				
9	5RN-H3606-00	.CAP, BULB	1				
10	5RN-H3333-00	.SCREW, LENS FITTING	1				
11	90167-04X00	SCREW, TAPPING	3				
12	5XL-H4730-00	TAILLIGHT UNIT ASSY	1				
13	5NR-H4733-00	.LENS, TAILLIGHT	1				
14	5XL-H3342-00	.LENS, FLASHER 2	1				
15	5XL-H4731-00	.REFLECTOR	1				
16	4BA-H4714-00	.BULB	1				
17	3TH-H3311-00	.BULB, FLASHER	1				
18	5AD-H3333-00	.SCREW, LENS FITTING	2				
19	5XL-H4534-00	.CORD, TAIL LIGHT	1				
20	5RN-H3606-00	.CAP, BULB	1				
21	5RN-H3333-00	.SCREW, LENS FITTING	1				
22	90167-04X00	SCREW, TAPPING	3				
23	4BA-H5130-00	REAR REFLECTOR ASSY	1				
24	9570M-05500	NUT, FLANGE	1				
25	5DS-H4740-00	LICENCE LIGHT ASSY	1				
26	5DS-H4726-00	.SCREW	2				
27	5DS-H4547-00	.CORD, LICENCE LIGHT	1				



5XL1300-A360



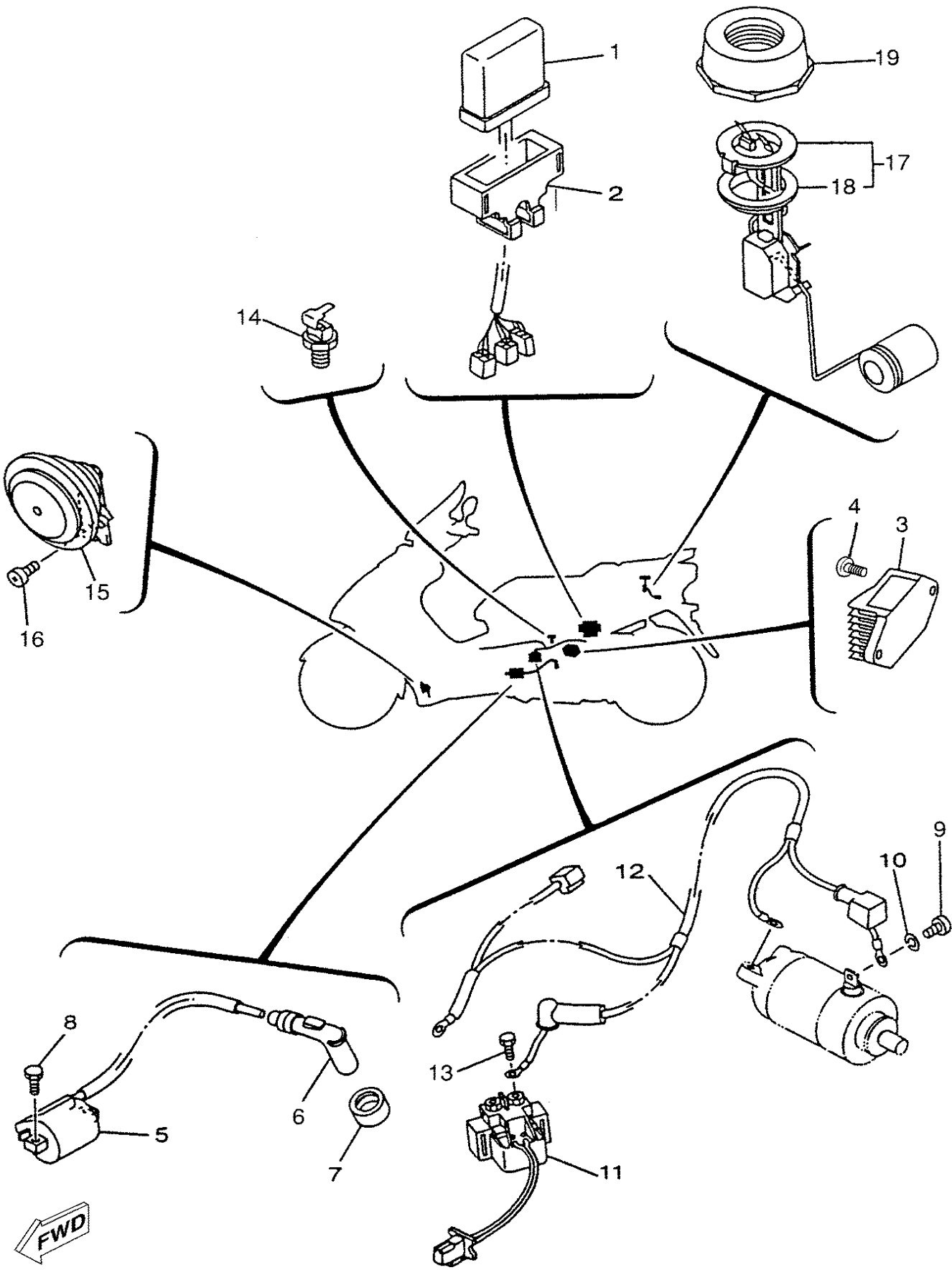


FIG. 38 ELECTRICAL 1

REF. NO.	PART NO.	DESCRIPTION	5XM3				REMARKS
1	5XM-H5540-00	C.D.I. UNIT ASSY	1				
2	5DS-H5546-00	BAND	1				
3	4HM-H1960-00	RECTIFIER & REGULATOR ASSY	1				
4	9890L-06020	SCREW, BIND	2				
5	3RW-H2310-00	IGNITION COIL ASSY	1				
6	4CW-H2370-00	PLUG CAP ASSY	1				
7	5DS-H2372-00	SEAL, PLUG CAP	1				
8	9700N-06016	BOLT	2				
9	9700L-05012	BOLT	1				
10	9290M-05100	WASHER	1				
11	3MW-81940-00	STARTER RELAY ASSY	1				
12	5DS-H1815-00	CORD, STARTER MOTOR	1				
13	9701L-06008	BOLT	2				
14	5MF-H3605-10	SENDER, WATER	1				
15	5DS-H3371-00	HORN	1				
16	9850L-08010	SCREW, PAN HEAD	1				
17	5DS-H5752-00	SENDER UNIT ASSY, FUEL METER	1				
18	4MJ-H5753-00	.GASKET, SENDER UNIT	1				
19	4MJ-F4261-00	HOUSING, FUEL METER	1				

5XL1300-A380

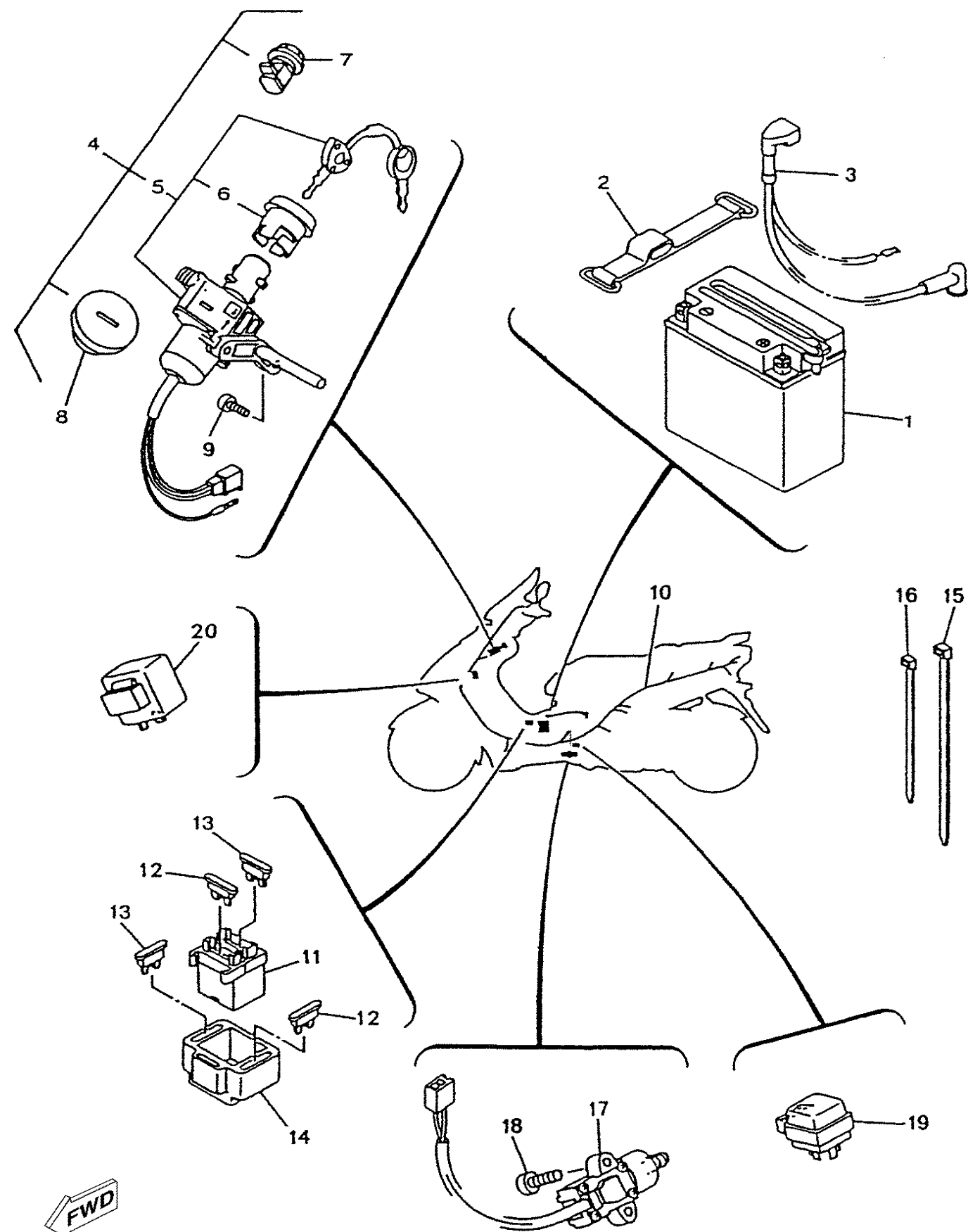


FIG. 39 ELECTRICAL 2

REF. NO.	PART NO.	DESCRIPTION	5XM3				REMARKS
1	5DS-H2110-00	BATTERY ASSY	1				
2	2RN-H2131-10	BAND, BATTERY	1				
3	5DS-H2115-00	WIRE, PLUS LEAD	1				
4	5NR-S2501-00	KEY SET	1				
5	5NR-H2501-00	.MAIN SWITCH STEERING LOCK	1				
6	5AD-H2552-00	..CAP, SWITCH	1				
7	4MJ-F1780-01	.LOCK ASSY	1				
8	5DS-F4610-01	.CAP ASSY	1				
9	90109-06X03	BOLT	2				
10	5XL-H2590-00	WIRE HARNESS ASSY	1				
11	5DS-H2152-00	HOLDER, FUSE	2				
12	5DS-H2151-00	FUSE	2				
13	5DS-H2151-20	FUSE	2				
14	5DS-H2155-00	BAND	1				
15	90464-80X00	CLAMP	7				
16	90464-50X03	CLAMP	3				
17	3LD-82566-50	SWITCH, SIDE STAND	1				
18	90110-05822	BOLT, HEXAGON SOCKET HEAD	2				
19	5DS-H1950-00	RELAY ASSY	2				
20	5SE-H3350-00	FLASHER RELAY ASSY	1				

5XL1300-A390

NUMERICAL INDEX

PART NO.	GRID NO.	PART NO.	GRID NO.	PART NO.	GRID NO.	PART NO.	GRID NO.	PART NO.	GRID NO.	PART NO.	GRID NO.
3UH-11133-01	B2	3KJ-15481-00	C2	5NR-E2482-00	B7	5DS-E5363-00	B14	5DS-F1511-00-LK	C8	5DS-F3125-00	C12
5XM-12111-00	B4	5XM-15524-00	C3	5NR-E2483-00	B7	3VL-E5371-10	B14	5DS-F1511-00-P6	C8		C12
1WG-12113-01	B4	164-22216-00	C11	5NR-E2491-00	B7	5DS-E5373-10	B14	5DS-F1511-00-PB	C8	5DS-F3126-10	C12
1WG-12116-00	B4	22F-23411-01	C13	5NR-E2492-00	B7	5DS-E5411-00	B15	2RN-F1518-00	C8	5DS-F3136-10	C12
3UH-12117-00	B4	22F-23412-01	C13	5XL-E2576-00	B6	5DS-E5417-00	B15	5DS-F1521-00	C8	5XL-F3141-00	C12
1WG-12118-00	B4	3VP-23416-00	C13	5CA-E3300-00	B8	5KD-E5421-00	B14	5DS-F1552-00	C8		C13
4TE-12119-00	B4	22F-2341E-00	C13	3UH-E3325-00	B8	5DS-E5426-00	B15	5NR-F1611-00	C8	5DS-F3144-00	C12
5XM-12121-00	B4	214-24535-00	B10	3KW-E3411-00	B8	5DS-E542A-00	B15	5DS-F1682-00	C8		C12
3UH-12151-00	B4	4HC-24618-00	C9	3UH-E3416-00	B14	5DS-E542B-00	B15	5DS-F1685-00	C8	5DS-F3145-00	C12
22F-12159-00	B4	22F-25381-10	D3	5NR-E3542-00	B13	5DS-E542C-00	B15	5DS-F1711-10	C9		C12
50M-12210-00	B5	5DS-81801-00	D13	5XM-E3585-00	B9	5XM-E5431-00	C2	5DS-F1716-10	C9	5DS-F3151-00	C12
4RF-12213-00	B5	50M-81828-M0	D13	5XM-E4301-00	B10	5DS-E5451-10	B15	5XL-F171L-00-LK	D11		C13
4HC-12411-00	B6	3MW-81940-00	E6	5DS-E4349-00	B9	5DS-E5453-00	B15	5XL-F171L-00-P3	D11	5DS-F3153-10	C13
11H-12469-00	B2	3LD-82566-50	E7	5DS-E4411-01	B9	5DS-E5455-00	B15	5XL-F171L-00-P6	D11	5DS-F3154-00	C12
5XL-14103-00	B10	5XM-E1111-00	B2	5DS-E4412-00	B9	5DS-E5461-10	B14	5DS-F171M-01-LK	D11		C13
5XL-14105-00	B10	5DS-E111F-00	B5	5DS-E4422-01	B9	5XM-E5471-00	B15	5DS-F171M-01-P6	D11	5DS-F3156-00	C12
5XL-1410A-00	B10	5XM-E1181-00	B2	5DS-E4437-00	B9	5DS-E5472-00	B15	5DS-F171M-01-PB	D11		C12
389-14147-00	B10	5DS-E1185-01	B6	5DS-E4451-00	B9	3UH-E5512-00	C3	5XL-F1721-00-LK	C9	5DS-F3157-00	C12
4HC-14196-00	B11	5DS-E1186-00	B2	5DS-E4452-00	B9	3UH-E5517-00	C3	5XL-F1721-00-P3	C9		C13
4HC-14197-00	B11	5XM-E1311-00	B2	5DS-E4453-00	B9	5DS-E5521-00	C3	5XL-F1721-00-P6	C9	5DS-F3165-00	C13
5XL-14197-00	B11	5XM-E1351-00	B2	5DS-E446M-00	B9	5DS-E5532-00	C3	5XL-F1731-00-LK	C9	5DS-F3165-10	C12
4JP-14243-01	B10	5XM-E1400-00	B3	5DS-E4476-00	B9	5XM-E5570-00	C3	5XL-F1731-00-P3	C9		C13
4KL-14272-01	B10	5XM-E1603-00	B3	5NR-E4611-00	B12	5KD-E6111-00	C4	5XL-F1731-00-P6	C9	5DS-F3165-20	C12
5SE-14286-00	B11	5XM-E1604-00	B3	5DS-E4613-00	B12	5KD-E6611-00	C4	5NR-F1741-00-LK	C9		C12
4JP-14323-00	B10	5XM-E1605-00	B3	5NR-E4614-00	B12	5XM-E6620-00	C4	5NR-F1741-00-P4	C9	5XL-F3170-00	C12
4HC-14340-01	B10	5XM-E1631-00	B3	5DS-E4628-00	B12	5XM-E6626-00	C4	5NR-F1741-00-P8	C9		C13
5SE-14341-00	B11	5XM-E1633-00	B3	5XM-E4711-00	B12	5KD-E7211-00	C6	5DS-F174X-00	C9	5DS-F3173-11	C12
38V-14342-22	B11	5XM-E1635-00	B3	5HT-E4714-00	B12	5KD-E7410-00	C6	5DS-F177J-00-LK	C9		C13
50M-14343-56	B11	5XM-E1636-00	B3	5XL-E4718-00-LK	B12	5NS-E7421-00	C6	5DS-F177J-00-P6	C9	5DS-F3183-00	C12
50M-14355-00	B11	5DS-E1951-00	B6	3WG-E4766-10	B12	5DS-E7611-00	C4	5DS-F177J-00-PB	C9		C13
4KL-14384-00	B10	5DS-E2156-00	B4	5HT-E4788-01	B12	5DS-E7620-00	C4	4MJ-F1780-01	D10	5XL-F3317-00	C13
25N-14385-00	B10	4CW-E2157-00	B5	5XL-E479U-00	B12	5XL-E7623-00	C4		E7	5DS-F3346-00	C13
4FP-14386-00	B10	5XL-E2170-00	B5	5HT-E479X-00	B12	5XM-E7632-00	C4	5XL-F1781-00	C9	5DS-F3356-00	C12
4HC-14390-25	B10	5DS-E2176-00	B5	4CW-E4806-00	B13	5XM-E7641-00	C4	5XM-F1781-00	C10		C13
4KL-14397-00	B10	5NS-E2231-00	B5	5XL-E4872-00	B12	5DS-E7653-00	C4	5DS-F178L-00	C9	5DS-F3418-00	C13
5H0-14397-00	B10	5NS-E2241-00	B5	5XL-E4883-00	B13	5XM-E7660-00	C4	4MJ-F1791-00	D10	21L-F3462-00	C13
4KL-14404-00	B10	5DS-E2279-00	B5	5XL-E4884-00	B13	5DS-E7664-00	C4	5XL-F1817-00	B7	5NR-F4110-00	C14
4KL-14415-00	B11	5DS-E2405-00	B7	5XM-E5100-00	B14	5XM-E7670-00	C4	5XL-F1871-00	B7	5DS-F414A-00	C14
4HC-14429-00	B10	5HT-E240A-00	B7	5DS-E5138-00	B14	5DS-E7684-00	C4	5DS-F2210-00	C11	4SN-F415A-00	C10
4KL-14536-00	B10	5DS-E2413-00	B6	5DS-E5191-00	B15	5XL-F1110-00-33	C7	4X6-F2216-00	B14	5DS-F415E-10	D11
4HC-14592-00	B10	5XM-E2420-00	B6	5MF-E5316-00	C2	5XL-F116A-00	C7	5XL-F3102-00	C12	5NR-F416A-00	C14
42H-14714-10	B12	5XM-E2422-00	B6	5DS-E5317-00	C7	5XL-F117A-00	C7	5XL-F3103-00	C12	5DS-F4181-00	C14
5GM-14803-00	B13	5DS-E2428-00	B6	5MF-E5326-00	C2	5NR-F118V-00	C7	5XL-F3108-00	C12	4MJ-F4183-00	D9
5XL-1490A-00	B10	5DS-E2450-00	B6	5MF-E5335-00	C2	5DS-F1232-00	C7		C13	4MJ-F4261-00	E6
5XM-1490J-00	B10	5HT-E2460-00	B7	5MF-E5337-00	C2	5DS-F1410-01	C7	5DS-F3110-10	C12	5NR-F4311-00	C14
4HC-14940-00	B10	5MF-E2462-01	B7	5MF-E5338-00	C2	5DS-F1420-00	C7		C12	5DS-F4313-00	C14
4HC-14958-00	B10	5DS-E2477-00	B6	5DS-E5351-00	B8	5NR-F142N-00	C7	5DS-F3111-00	C12	5DS-F4318-00	C14
5DS-15407-01	B15	5XL-E2481-00	B7	3VL-E5363-00	B14	5DS-F1481-00	C7		C13	5KK-F4500-00	C14

NUMERICAL INDEX

PART NO.	GRID NO.	PART NO.	GRID NO.	PART NO.	GRID NO.	PART NO.	GRID NO.	PART NO.	GRID NO.	PART NO.	GRID NO.
5DS-F4610-01	C14	5XM-F5920-00	C11	5DS-F8371-00	D10	5RN-H3333-00	E3	4BA-H5130-00	E3	90154-06X06	B9
	E7	5DS-F5924-00	D4	5NR-F837L-10	D10	5XL-H3342-00	E3	5DS-H5510-00	D12	90154-06X15	D12
5XL-F4710-00	C15	5NR-F6110-00	D7	5DS-F837N-00	D11	5SE-H3350-00	E7	5XM-H5540-00	E6	90157-04X02	E2
5DS-F4726-00	C15	5NR-F6132-00	D8	5DS-F8385-01-LK	D11	5DS-H3371-00	E6	5DS-H5546-00	E6	90159-06816	C8
5XL-F473R-00	C15	5NR-F6143-00-4B	D7	5DS-F8385-01-P6	D11	5XL-H3507-00	D15	5DS-H5550-00	D12	90159-06835	B7
2RN-F4741-00	C15	5DS-F6145-10	D7	5DS-F8385-01-PB	D11	5XL-H3510-00	D15	5DS-H5752-00	E6		B7
	C15	5XL-F6234-00	D7	5XL-F838N-00	B15	5XL-H3511-00	D15	4MJ-H5753-00	E6	90159-06X00	D10
	C7	5HT-F6240-00	D7	5DS-F839K-00	D10	5XL-H3517-00	D15	5NR-S2501-00	E7		D7
5XL-F4750-00	C15	5DS-F6241-00	D7	5DS-F839L-11	D10	5MF-H3605-10	E6	5DS-W3340-20	C13	90167-03X00	E4
5DS-F4758-00	C15	5HT-F6246-00	D7	5DS-H1800-00	D13	5RN-H3606-00	E3	5NR-W5371-10	C11	90167-03X03	D15
5DS-F475M-00	C15	5DS-F6280-00	D7	5DS-H1815-00	E6		E3	90105-06X04	B2	90167-04X00	B9
5NR-F4773-00-LK	C15	5DS-F6290-00	D7	5DS-H1950-00	E7	5NR-H3756-01	D3		B2		C9
5NR-F4773-00-P4	C15	5XL-F6311-00	D7	4HM-H1960-00	E6	5DS-H3922-01	D8		B5		C9
5NR-F4773-00-P8	C15	5NR-F7111-00	D9	5DS-H2110-00	E7		D8		B6		C9
5AD-F4780-00	C15	5DS-F7113-01	D9	5DS-H2115-00	E7	4SB-H3945-00	D8	90105-08121	C11		C9
5DS-F4781-00	C15	2JW-F7114-10	C7	1TK-H2131-00	D2		D8	90105-08825	B5		D10
5DS-F478E-00	C15		D9	2RN-H2131-10	E7	5MF-H3945-00	E5	90105-10036	D7		D10
5DS-F479A-00	C15	5DS-F7244-00	D9	5DS-H2151-00	E7		E5	90105-106A2	C7		D10
5DS-F5105-00	D3	5DS-F7311-00	D9	5DS-H2151-20	E7	5NR-H3972-00	E5	90109-06X03	E7		D10
5DS-F5117-00	D3	5DS-F7351-00	D9	5DS-H2152-00	E7	5HT-H3973-00	E5	90109-06X05	C15		D10
5DS-F5168-00	D3	5DS-F7414-00	C7	5DS-H2155-00	E7	5XL-H3975-00	E5		C8		D11
3VL-F5170-10	D3		D9	5DS-H2178-01	D9	5NR-H3976-00	E5		C9		D11
	D5		D9	3RW-H2310-00	E6	5XL-H3980-00	D8		D10		D11
5NR-F5338-00	D5	5DS-F7445-00	D9	4CW-H2370-00	E6		D8	90109-06X06	D7		D11
5NR-F580T-00	D4	5DS-F7446-00	D9	5DS-H2372-00	E6	5DS-H4103-00	E2	90109-100E8	D9		D14
5NR-F580W-00	D6	5XL-F7481-00	D9	5NR-H2501-00	E7	5DU-H4112-00	E2	90110-05822	E7		D14
5NR-F5811-00	D4	5XL-F8100-00	D2	5AD-H2552-00	E7	5NR-H4310-00	E2	90110-06X02	B6		D7
5NR-F5811-10	D6	5XL-F8199-E1	C15	5HT-H2558-00	B7	5AD-H4314-00	E2		D13		D7
5DS-F5824-10	D4	5NR-F8311-00-LK	D10	5MF-H2558-00	B7	5NR-H4323-00	E2	90110-06X03	B15		D9
5NR-F5824-00	D6	5NR-F8311-00-P4	D10	5HT-H2560-10	B7	3WG-H4324-00	E2	90110-06X04	B2		E2
5DS-F5825-00	D4	5NR-F8311-00-P8	D10	5MF-H2560-00	B7	5AD-H4332-00	E2		B2		E3
5NR-F5825-00	D6	5DS-F8312-00	D10	5XL-H2590-00	E7	5NR-H4340-00	E2		B6		E3
5NR-F582W-00	D6	5DS-F8317-00	C8	5XL-H3310-00	D14	5NR-H4533-00	E3	90110-06X05	B14	90167-04X02	B7
5DS-F5831-00	D4		C9	3TH-H3311-00	E3	5XL-H4534-00	E3	90110-06X06	B15		B9
5NR-F583T-01	D8		C9		E3	5DS-H4547-00	E3	90110-06X21	B5		C9
5NR-F583V-01	D8		C9	5XL-H3311-00	D14	5XL-H4710-00	E3	90110-06X26	B5		D9
5NR-F5852-00	D8		D10		D14	5XL-H4711-00	E3	90110-06X51	B12	90167-04X03	B7
	D8		D10	5XL-H3312-00	D14	4BA-H4714-00	E3	90116-08624	B14	90170-05302	B4
4SB-F5867-10	D8		D11	5XL-H3314-00	D14		E3	90116-08625	B14	90170-12181	D12
	D8		D11	5XL-H3320-00	D14	5NR-H4721-00	E3	90119-06118	D9	90170-12X01	C4
5NR-F5872-00	D8		D11	5XL-H3322-00	D14	4MJ-H4725-00	C8	90119-06X02	B7	90170-36X00	C5
5NR-F5873-00	D8	5DS-F8317-10	B7	5XL-H3324-00	D14	5DS-H4726-00	E3	90149-06X03	B15	90176-08026	B2
5NR-F5876-10	D8	5XL-F831A-10	D10	5XL-H3332-00	E3	5XL-H4730-00	E3		B6	90179-06403	C15
2RN-F5877-00	D8	5DS-F8343-00	D11	5AD-H3333-00	D14	5XL-H4731-00	E3		C3	90179-06X04	B9
	D8	5NR-F835U-00-LK	D10		D14	5NR-H4733-00	E3		D12	90179-14469	C4
5NR-F587A-00	C11	5NR-F835U-00-P4	D10		E3	5DS-H4740-00	E3	90149-06X07	B9	90179-25X00	C13
5DS-F5919-00	D4	5NR-F835U-00-P8	D10		E3	5DS-H4744-00	E2	90149-08814	D4	90183-05813	D10
5NR-F5919-00	D6	5DS-F8368-00	D11	5RN-H3333-00	E3		E4		D6	90183-06816	C7

NUMERICAL INDEX

PART NO.	GRID NO.	PART NO.	GRID NO.	PART NO.	GRID NO.	PART NO.	GRID NO.	PART NO.	GRID NO.
90185-10037	D9	90430-06X00	B6	93101-21170	C4	9570N-06500	C15	9890N-06050	B6
90185-10840	C11	90430-08816	B14	93102-18895	D3	9580L-06012	C7	99001-05600	B8
	C7		B14	93102-19477	B15		D10	99009-17400	C7
	C7	90446-14X00	B9	93102-22294	B14	9580L-06016	C7	99009-25400	C6
	D7	90450-25823	C14	93102-25800	C4		C8	99236-00080	C10
90185-14815	C11	90450-27X00	B7	93102-32298	C6	9580M-06012	B13	99237-00080	C10
90201-05X02	B7		B7	93103-10168	B6		C7	99530-08012	B15
90201-062A8	B9	90450-60X01	B9	93104-41802	C4		C7	99530-10114	B14
90201-06815	C15	90462-07X00	B5	93106-28824	C11		C8		B2
90201-06821	D7		B6	93210-09729	B4	9580M-06016	C15		B2
90201-06X01	B12	90464-13804	C14	93210-14104	B14	9580M-06025	C15		
90201-06X09	B2	90464-50X03	C14	93210-15171	B5		C15		
90201-077F5	B8		D8	93210-25711	D13	95817-08016	B14		
90201-08609	B2		E7	93210-26130	B14		B14		
90201-08X16	B12	90464-80X00	B15	93210-347A1	B8	9582L-08030	D4		
90201-10118	D8		D7	93210-35537	B9	9582L-10035	D9		
	D8		E7		B9	9582M-08012	C7		
90201-108A3	C3	90465-05X00	D10	93210-43X00	C4	9582M-08025	C11		
90201-10X06	D7	90467-09X00	B13	93210-44X00	B2	9582M-08040	C11		
90201-15X01	C6	90467-11106	B14	93210-55699	D13		D6		
90201-16X04	C4	90467-11108	B6	93210-63X00	B6	9582M-10030	B12		
90201-16X09	C4	90467-11X01	B9	93211-077A5	B15		C7		
90201-22X00	D5		C14	93306-003Y9	C3	9582N-06020	C15		
90202-15X00	D9	90467-12X00	B9	93306-201Y2	D3	9700L-05012	E6		
90202-26X00	C13	90467-15X00	B13	93306-202YR	C11	9700N-06016	E6		
90208-12050	C4	90467-16X00	B13	93306-203YC	C6	9701L-06008	E6		
90241-10015	C15	90467-20050	B6	93306-205X8	C4	9751M-08640	C11		
90280-03045	B3	90480-11X04	B12	93306-272Y1	C6	9760L-06216	D8		
90336-07034	B15	90480-12237	B12	93306-301XB	C6		D8		
90387-060G7	B12	90480-12X01	B15	93306-303X2	C6	9760M-06130	B9		
90387-068F9	B15	90480-14X00	D7	93311-315Y4	C6	97707-30514	D15		
90387-06X03	B9	90480-20X00	B7	93315-110Y0	C3	97801-05010	B10		
90387-06X04	C8	90480-30X00	C2	93399-999Y2	C13	98501-04012	B10		
90387-06X05	C8	90501-04X00	C4	93430-08X00	C4	9850L-08010	E6		
90387-06X06	D11	90501-10826	B6	93450-16X01	B3	9850M-05010	D7		
90387-06X26	B12	90501-16829	B8	93450-35015	C3	9850M-06016	C11		
	C15	90506-26X00	D9	93602-13832	B8	9850M-06020	B9		
90387-06X27	C14	90506-34X00	D9	93603-12833	B8		C8		
90387-07X01	D7	9131L-06016	B12	93604-10X00	B6	98707-06020	B8		
90387-15X00	C11	9131L-08020	B12	94591-48094	B5	98901-04006	B10		
90387-15X02	C11	9131M-06012	B12	94701-00X00	B2	9890L-06016	B12		
90387-15X04	C11	9131M-06020	B13	9530L-06600	B9	9890L-06020	E6		
90387-168D2	C4	9131N-06080	B14	95607-08200	B12	9890M-06016	C8		
90387-168S2	C3	92907-12600	D12	95607-12200	D3		D11		
90430-06014	B14	9290L-05200	D10	95617-08620	B2		D11		
	B15	9290M-05100	E6	9570L-06300	C15	9890N-06020	B15		
	B2	9290M-06200	B12	9570L-06500	C8		C2		
90430-06X00	B6	93101-19172	B15	9570M-05500	E3	9890N-06025	B6		