



# PARTS CATALOGUE

**YP250** (5SJ9) EUROPE

**YP250R** (5SJB) AUSTRALIA

**YAMAHA**  
**GENUINE**  
Parts & Accessories

1B5SJ-300EB

( 2B5SJ-300EB )

YP250/YP250R  
PARTS CATALOGUE  
©2002 by Yamaha Motor Co., Ltd.  
1st edition, December 2002  
All rights reserved.  
Any reprinting or unauthorized use  
without the written permission of  
Yamaha Motor Co., Ltd.  
is expressly prohibited.  
Printed in Japan.

**A3**



**A4**

# FOREWORD

This Parts Catalogue is related to the parts for the model(s) on the cover page. When you are ordering replacement parts, please refer to this Parts Catalogue and quote both part numbers and part names correctly.

1. Modifications or additions which have been made after the issue of the Parts Catalogue will be announced in the Yamaha Parts News.

It is advisable that you make the necessary corrections to the Parts Catalogue according to the Yamaha Parts News.

2. Abbreviations

The following abbreviations are used in this Parts Catalogue.

“UR” Use specified parts number.

“UN” Use as many as needed.

“AP” Alternate Parts

“LM” Locally Made (Parts need to be ordered locally)

“F#” Frame No. (Applicable machine No.)

“O/S” Over Size

3. The number of components for assembly

- Parts, which are to be supplied in an assembly, are listed with a dot (.) in front of the part name as shown below.
- The numeral appearing to the right of each component part indicates the quantity of parts for each assembly unit.

PART NO.	DESCRIPTION	Q'TY	REMARKS
2F5-83310-60	FRONT FLASHER LIGHT ASSY	2	
115-83311-60	.BULB (6V-18W)	1	

4. Applicable colours of graphics are represented in the “REMARKS” as shown below.

PART NO.	DESCRIPTION	Q'TY	REMARKS
2N4-24110-00-X5	FUEL TANK COMP.	2	MXR
3J1-24240-10	.GRAPHIC, FUEL TANK	1	FOR MXR

5. Note that the illustrations for reference in finding parts numbers are not to be used for assembling. When assembling, please use the applicable service manual.

6. The asterisk (\*) before a reference number indicates modified items after the first edition.

# FOREWORD

7. Applicable Serial No.

Engine Serial No.

Frame Serial No.

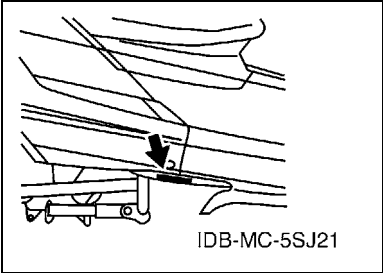
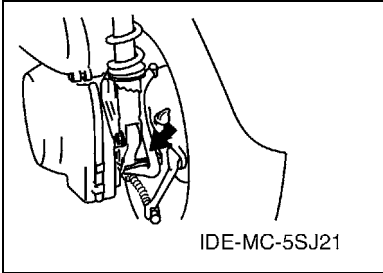

8. Applicable Colour Code

Abbreviation	Colour Name	Colour Code
DNBME	DARK GRAYISH BLUE METALLIC E	0866
DNMA	DARK GRAY METALLIC A	0821
DRMD	DULL RED METALLIC D	0779
MAS	MARBLE SILVER	000L
SL	SILVER	0035

# MODEL LABEL

(1) A label called "Model Label" is affixed in the location as indicated in (3) below. When using this parts catalogue, please be sure to cross-reference the "model code – production code No." in the catalogue with the "model code – production code No." indicated on the Model Label affixed onto the product concerned.

(2) "Model Label" Indication

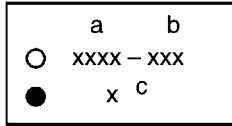

a: Model Type Code  
b: Production Code No.  
c: Colouring Type

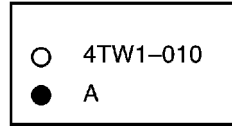

(3) Model Label Affixing Location

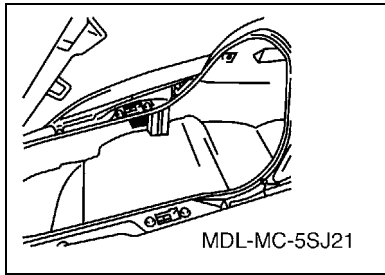

(4) Colouring Information

Model Code	Colouring Type Code	Colour Code	Colour Name	Abbreviation
5SJ9	A	000L	MARBLE SILVER	MAS
	B	0779	DULL RED METALLIC D	DRMD
	C	0866	DARK GRAYISH BLUE METALLIC E	DNBME
	D	0821	DARK GRAY METALLIC A	DNMA
5SJB	A	000L	MARBLE SILVER	MAS
	B	0779	DULL RED METALLIC D	DRMD
	C	0866	DARK GRAYISH BLUE METALLIC E	DNBME

(5) Model Code – Production Code Number of Model Listed in This Parts Catalogue

Model Code	Production Code No.	Country (destination)	Model Code	Production Code No.	Country (destination)
5SJ9	020	BELGIUM			
	030	SWITZERLAND			
	060	UNITED KINGDOM			
	070	GREECE			
	080	ITALY			
	090	NETHERLANDS			
	100	NORWAY			
	110	PORTUGAL			
	120	SWEDEN			
5SJB	010	AUSTRALIA			

# CONTENTS

## ENGINE

CYLINDER .....	B2
CRANKSHAFT. PISTON .....	B3
VALVE .....	B4
CAMSHAFT. CHAIN .....	B5
WATER PUMP .....	B6
RADIATOR. HOSE .....	B7
OIL PUMP .....	B9
INTAKE .....	B10
CARBURETOR .....	B11
EXHAUST .....	B13
CRANKCASE .....	B15
CRANKCASE COVER 1 .....	C3
STARTER .....	C5
CLUTCH .....	C6
TRANSMISSION .....	C8

## CHASSIS

FRAME .....	C9
FENDER .....	C10
SIDE COVER .....	C11
REAR ARM. SUSPENSION .....	C13
STEERING .....	C14
FUEL TANK .....	D2
SEAT .....	D4
FRONT WHEEL .....	D6
FRONT BRAKE CALIPER .....	D7
REAR WHEEL .....	D8
REAR BRAKE CALIPER .....	D9
STEERING HANDLE. CABLE .....	D10
FRONT MASTER CYLINDER .....	D11
STAND. FOOTREST .....	D12
LEG SHIELD .....	D14
GENERATOR .....	E3
STARTING MOTOR .....	E4
FLASHER LIGHT .....	E5
METER .....	E6
HEADLIGHT .....	E7
TAILLIGHT .....	E8
HANDLE SWITCH. LEVER .....	E9
ELECTRICAL 1 .....	E10
ELECTRICAL 2 .....	E12

## INDEX

NUMERICAL INDEX .....	M1
-----------------------	----

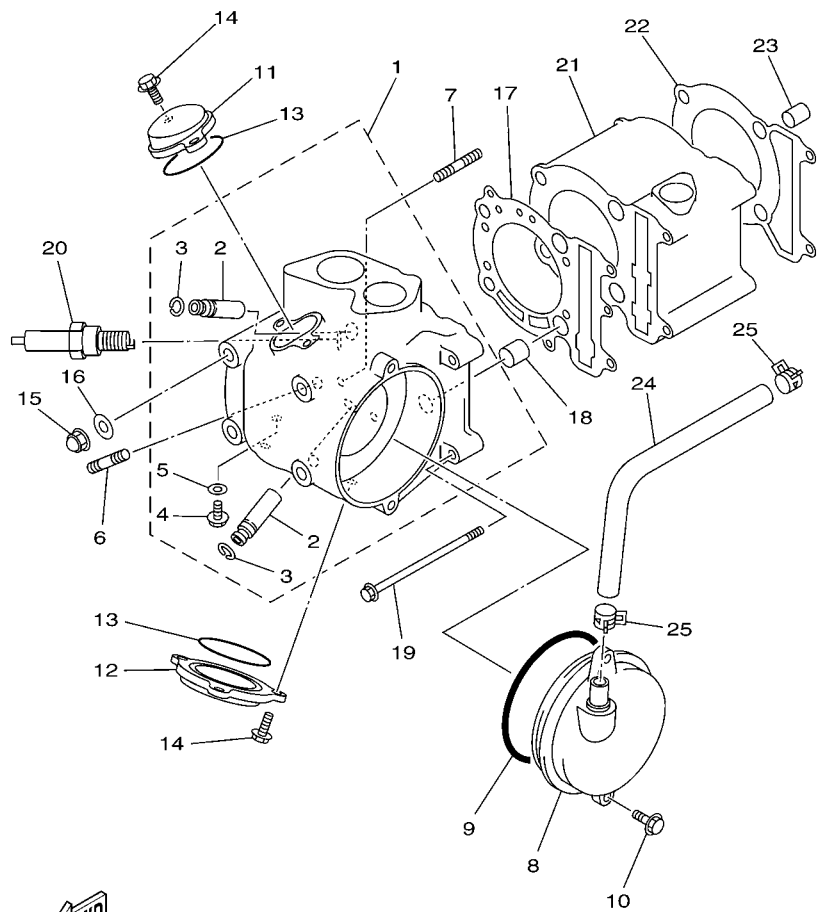

**FWD**  
5GM1010-0010

**FIG. 1 CYLINDER**

REF. NO.	PART NO.	DESCRIPTION	SSJ9	SSJ8		REMARKS
1	5GM-11101-00	CYLINDER HEAD ASSY	1	1		
2	4G0-11133-10	.GUIDE, INTAKE VALVE	2	2		
3	93440-10085	.CIRCLIP	2	2		
4	90153-06029	.SCREW, HEXAGON	1	1		
5	90430-06014	.GASKET	1	1		
6	95617-08620	BOLT, STUD	2	2		
7	95617-06615	BOLT, STUD	2	2		
8	4HC-11160-00	BREATHER ASSY	1	1		
9	93210-92448	O-RING	1	1		
10	95027-06020	BOLT, FLANGE	2	2		
11	3GC-11186-00	COVER, CYLINDER HEAD SIDE 2	1	1		
12	3GC-11187-00	COVER, CYLINDER HEAD SIDE 3	1	1		
13	93210-57634	O-RING	2	2		
14	95027-06020	BOLT, FLANGE	5	5		
15	90176-08026	NUT, CROWN	4	4		
16	90201-08609	WASHER, PLATE	4	4		
17	4HC-11181-01	GASKET, CYLINDER HEAD 1	1	1		
18	99530-14016	PIN, DOWEL	2	2		
19	95027-06120	BOLT, FLANGE	2	2		
20	94701-00333	PLUG, SPARK (NGK DR8EA)	1	1		
21	4HC-11311-00	CYLINDER 1	1	1		
22	4HC-11351-00	GASKET, CYLINDER	1	1		
23	99530-10114	PIN, DOWEL	2	2		
24	4HC-11166-00	PIPE, BREATHER 1	1	1		
25	90467-13064	CLIP	2	2		



**FIG. 2 CRANKSHAFT. PISTON**

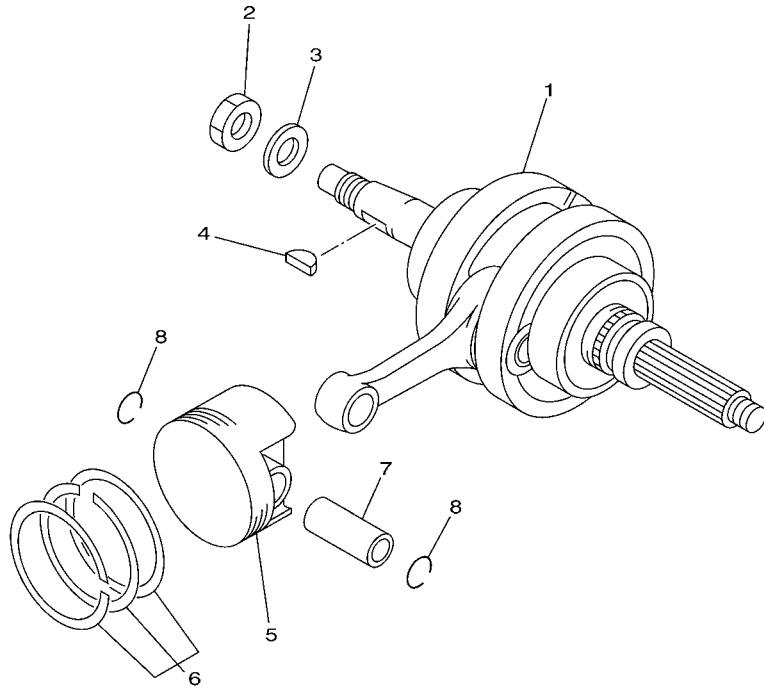

REF. NO.	PART NO.	DESCRIPTION	SSJ9	SSJ8		REMARKS
1	5GM-11400-10	CRANKSHAFT ASSY	1	1		
2	90170-16425	NUT	1	1		
3	90201-160F6	WASHER, PLATE	1	1		
4	90280-05013	KEY, WOODRUFF	1	1		
5	4HC-11631-01	PISTON (STD)	1	1		
	4HC-11636-01	PISTON (0.50MM O/S)	1	1		AP
	4HC-11638-01	PISTON (1.00MM O/S)	1	1		AP
6	4HC-11603-00	PISTON RING SET (STD)	1	1		
	4HC-11605-00	PISTON RING SET (0.50MM O/S)	1	1		AP
	4HC-11607-00	PISTON RING SET (1.00MM O/S)	1	1		AP
7	4JH-11633-00	PIN, PISTON	1	1		
8	90468-12069	CLIP	2	2		

 5GM1010-0020

**FIG. 3 VALVE**

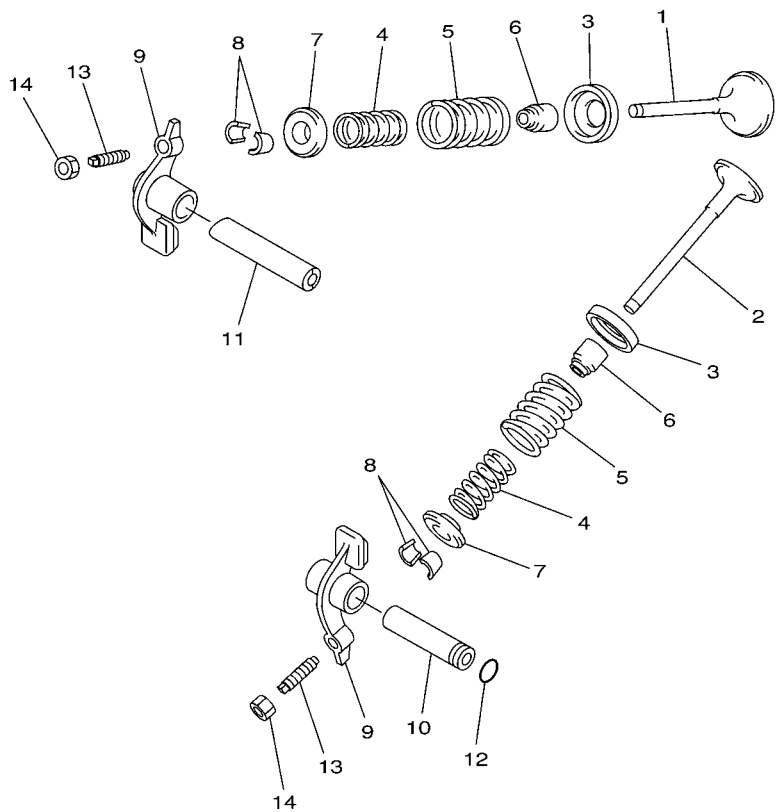

REF. NO.	PART NO.	DESCRIPTION	SSJ9	SSJ8		REMARKS
1	5GM-12111-00	VALVE, INTAKE	1	1		
2	5H0-12121-01	VALVE, EXHAUST	1	1		
3	4G0-12116-01	SEAT, VALVE SPRING	2	2		
4	4HC-12113-00	SPRING, VALVE INNER	2	2		
5	4HC-12114-00	SPRING, VALVE OUTER	2	2		
6	5H0-12119-00	SEAL, VALVE STEM	2	2		
7	4G0-12117-00	RETAINER, VALVE SPRING	2	2		
8	4G0-12118-00	COTTER, VALVE	4	4		
9	36X-12151-00	ARM, VALVE ROCKER	2	2		
10	3Y1-12156-00	SHAFT, ROCKER 2	1	1		
11	5H0-12146-00	SHAFT, ROCKER	1	1		
12	93210-09165	O-RING	1	1		
13	2NX-12159-00	SCREW, VALVE ADJUSTING	2	2		
14	90170-06128	NUT	2	2		



4HC1010-5030

FIG. 4 CAMSHAFT. CHAIN

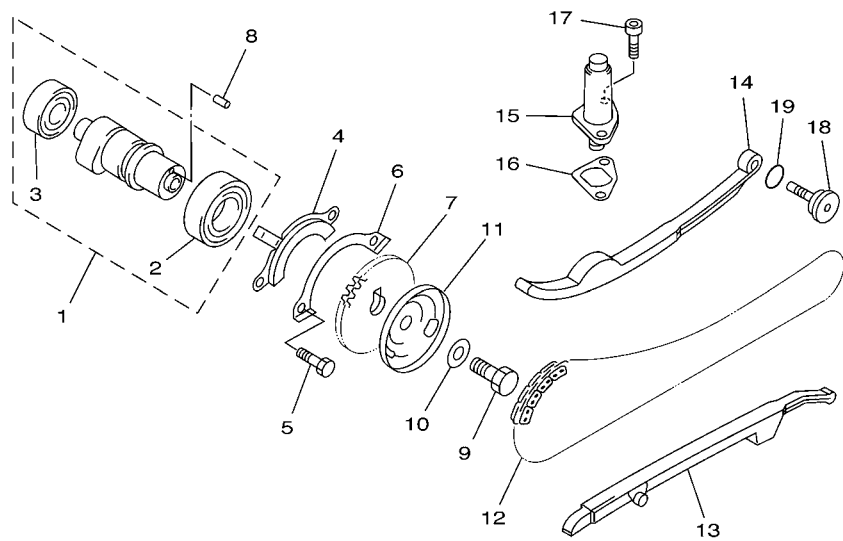

REF. NO.	PART NO.	DESCRIPTION	SSJ9	SSJ8		REMARKS
1	4HC-12170-00	CAMSHAFT ASSY 1	1	1		
2	93306-00518	.BEARING	1	1		
3	93306-20204	.BEARING (B6202Z)	1	1		KOYO
4	4GA-1111F-00	PLATE	1	1		
5	97007-06012	BOLT	2	2		
6	90215-06184	WASHER, LOCK	1	1		
7	4HC-12176-00	SPROCKET, CAM CHAIN	1	1		
8	93604-10011	PIN, DOWEL	1	1		
9	90101-10303	BOLT	1	1		
10	90201-10591	WASHER, PLATE	1	1		
11	4KB-11145-00	PLATE, BREATHER 2	1	1		
12	94581-63104	CHAIN	1	1		
13	4HC-12231-00	GUIDE, STOPPER 1	1	1		
14	4HC-12241-00	GUIDE, STOPPER 2	1	1		
15	2UJ-12210-01	TENSIONER ASSY, CAM CHAIN	1	1		
16	4RF-12213-00	GASKET, TENSIONER CASE	1	1		
17	91317-06014	BOLT	2	2		
18	4HC-12157-00	BOLT	1	1		
19	93210-15171	O-RING	1	1		



4HC1010-5040

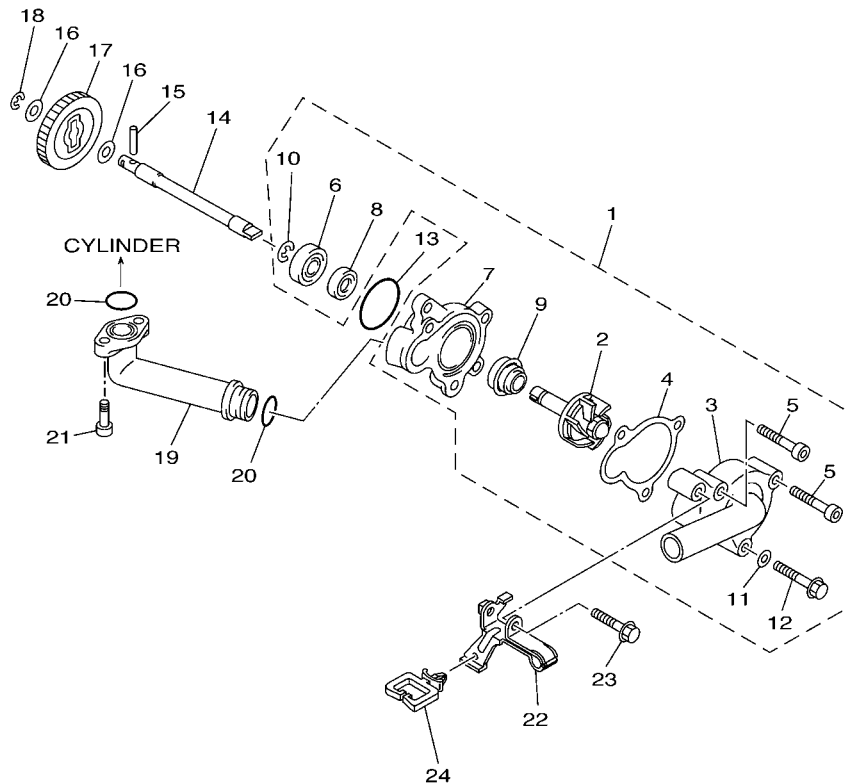

5SJ2300-A050

FIG. 5 WATER PUMP

REF. NO.	PART NO.	DESCRIPTION	5SJB	5SJB	REMARKS
1	5GM-12420-01	WATER PUMP ASSY	1	1	
2	5GM-12450-01	.IMPELLER SHAFT ASSY	1	1	
3	4HC-12422-01	.COVER, HOUSING	1	1	
4	4HC-12428-10	.GASKET, HOUSING COVER 2	1	1	
5	91317-06035	.BOLT	2	2	
6	93306-00006	.BEARING (B6000)	1	1	
7	4HC-12421-00	.HOUSING, WATER PUMP	1	1	
8	93101-10090	.OIL SEAL	1	1	
9	11H-12438-10	.SEAL, MECHANICAL	1	1	
10	99009-10400	.CIRCLIP	1	1	
11	90430-06014	.GASKET	1	1	
12	95027-06035	.BOLT, FLANGE	1	1	
13	93210-33133	O-RING	1	1	
14	5GM-12426-00	SHAFT	1	1	
15	93603-22028	PIN, DOWEL	1	1	
16	90201-08512	WASHER, PLATE	2	2	
17	4HC-12459-00	GEAR, IMPELLER SHAFT	1	1	
18	99001-07600	CIRCLIP	1	1	
19	4HC-12446-00	JOINT	1	1	
20	93210-16275	O-RING	2	2	
21	91317-06016	BOLT	2	2	
22	4HC-2637G-00	HOLDER, WIRE	1	1	
23	95027-06030	BOLT, FLANGE	1	1	
24	90464-23199	CLAMP	1	1	

FIG. 6 RADIATOR. HOSE

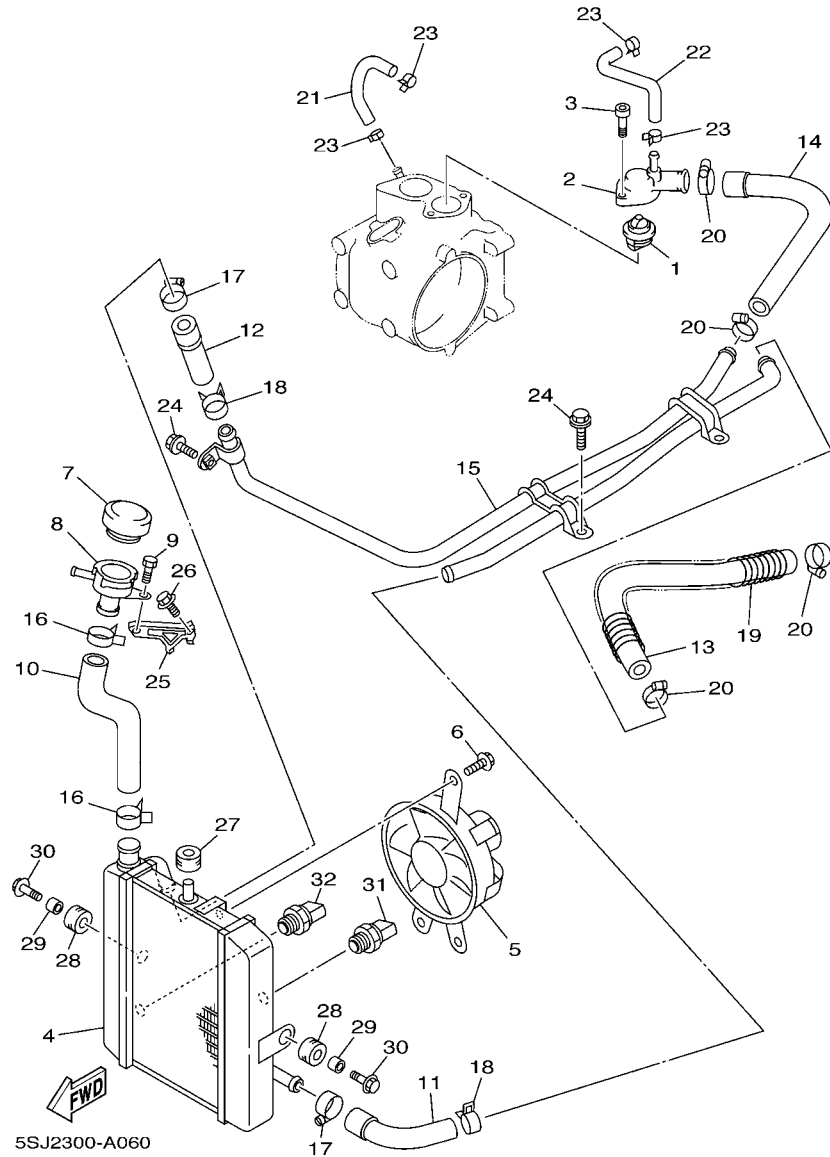

5SJ2300-A060

REF. NO.	PART NO.	DESCRIPTION	5S:J9	5S:J8	REMARKS
1	4HC-12411-00	THERMOSTAT	1	1	
2	4HC-12413-00	COVER, THERMOSTAT	1	1	
3	91317-06020	BOLT	2	2	
4	5GM-12461-10	RADIATOR ASSY	1	1	
5	5GM-12405-00	BLOWER ASSY	1	1	
6	95024-06010	BOLT, FLANGE	3	3	
7	4JH-12462-00	CAP, RADIATOR	1	1	
8	4HC-12591-00	SUPT, FILLER NECK	1	1	
9	97007-05012	BOLT	1	1	
10	5GM-12481-00	PIPE 1	1	1	
11	5GM-12482-00	PIPE 2	1	1	
12	5GM-12483-00	PIPE 3	1	1	
13	5GM-12484-00	PIPE 4	1	1	
14	5GM-12485-00	PIPE 5	1	1	
15	5GM-12476-00	PIPE 6	1	1	
16	90467-26131	CLIP	2	2	
17	90450-28014	HOSE CLAMP ASSY	2	2	
18	90467-22100	CLIP	2	2	
19	90501-14001	SPRING, COMPRESSION	1	1	
20	90450-28014	HOSE CLAMP ASSY	4	4	
21	4HC-12576-00	HOSE 1	1	1	
22	4HC-12577-00	HOSE 2	1	1	
23	90467-10038	CLIP	4	4	
24	95807-06010	BOLT, FLANGE	3	3	
25	5GM-12443-00	STAY	1	1	
26	95807-06008	BOLT, FLANGE	1	1	
27	90480-14323	GROMMET	1	1	

FIG. 6 RADIATOR. HOSE

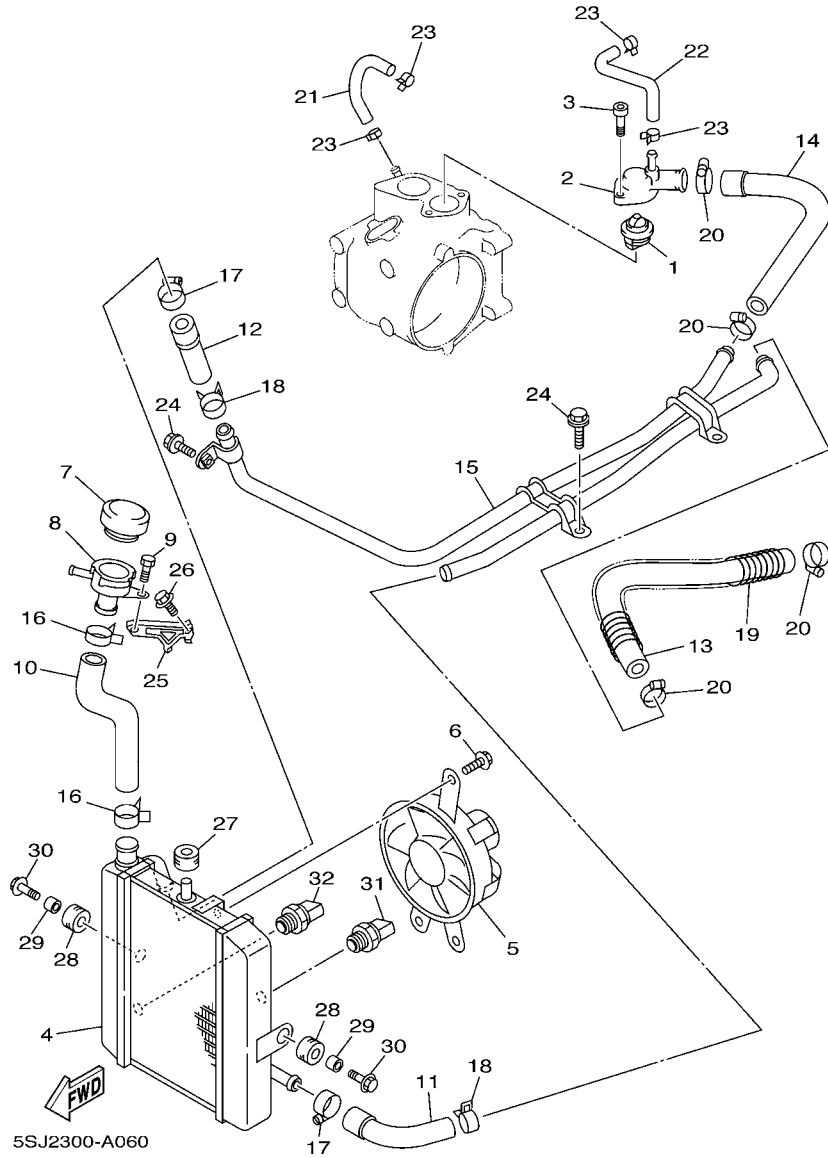

REF. NO.	PART NO.	DESCRIPTION	5S,UG	5S,UB		REMARKS
28	90480-16301	GROMMET	2	2		
29	90387-0714B	COLLAR	2	2		
30	90119-06118	BOLT, WITH WASHER	2	2		
31	5GM-82560-00	THERMO SWITCH ASSY	1	1		
32	5GH-82560-00	THERMO SWITCH ASSY	1	1		
-----						
-----						
-----						
-----						
-----						
-----						
-----						
-----						
-----						
-----						

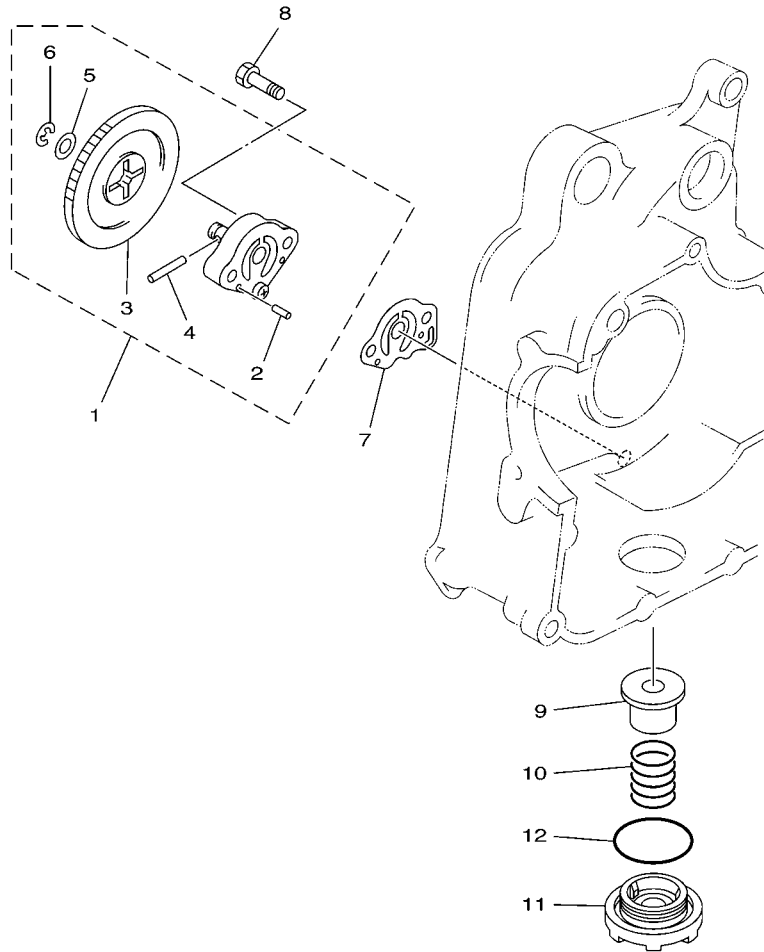
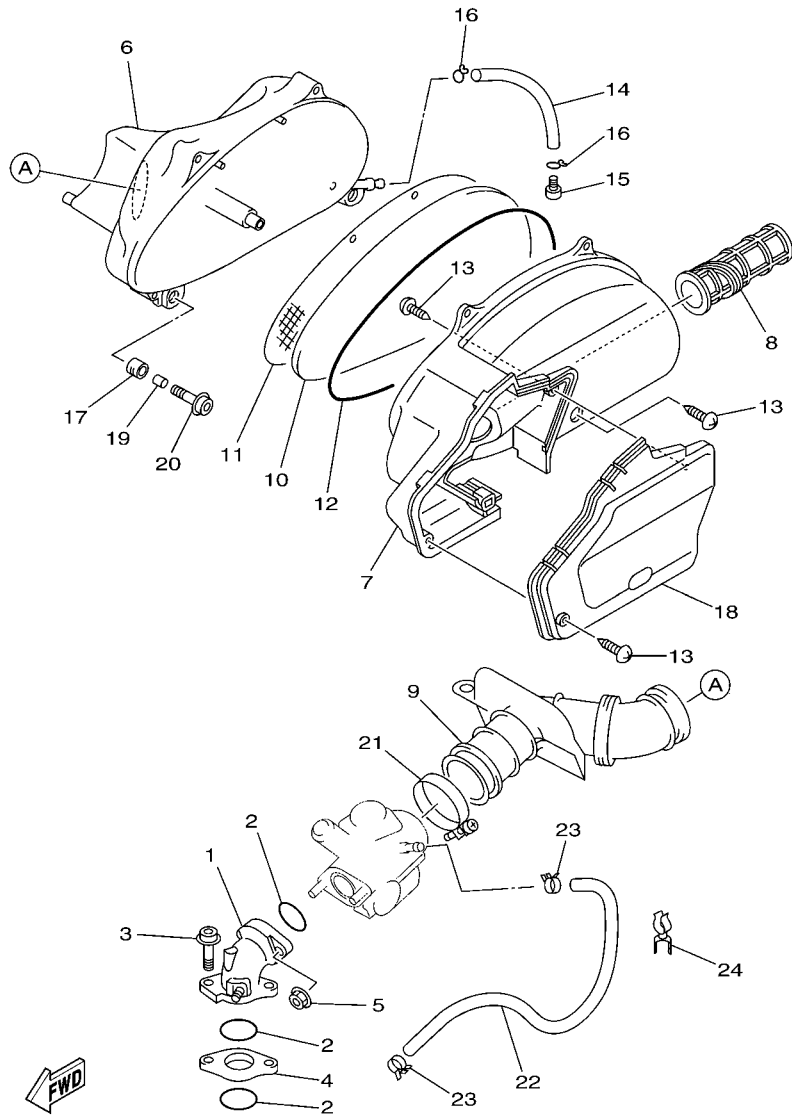

FIG. 7 OIL PUMP

REF. NO.	PART NO.	DESCRIPTION	SSJ9	SSJ8	REMARKS
1	4HC-13300-00	OIL PUMP ASSY	1	1	
2	93603-12221	.PIN, DOWEL	2	2	
3	4HC-13325-00	.GEAR, PUMP DRIVEN	1	1	
4	93603-22028	.PIN, DOWEL	1	1	
5	90201-08512	.WASHER, PLATE	1	1	
6	99001-06600	.CIRCLIP	1	1	
7	4HC-13475-00	GASKET	1	1	
8	92017-06025	BOLT, BUTTON HEAD	2	2	
9	51Y-13411-00	STRAINER, OIL	1	1	
10	90501-18576	SPRING, COMPRESSION	1	1	
11	4HC-15351-00	PLUG, DRAIN	1	1	
12	93210-35520	O-RING	1	1	

  
4UC3300-8070



5GM1010-0080

FIG. 8 INTAKE

REF. NO.	PART NO.	DESCRIPTION	SSJG	SSJB	REMARKS
1	4HC-13586-11	JOINT, CARBURETOR 1	1	1	
2	93210-35537	O-RING	3	3	
3	90109-067E6	BOLT	2	2	
4	4HC-13595-00	JOINT	1	1	
5	95707-06500	NUT, FLANGE	2	2	
6	4HC-14411-00	CASE, AIR CLEANER 1	1	1	
7	5GM-14412-01	CAP, CLEANER CASE 1	1	1	
8	5GM-14437-00	DUCT	1	1	
9	4HC-14453-01	JOINT, AIR CLEANER 1	1	1	
10	4HC-14451-00	ELEMENT, AIR CLEANER	1	1	
11	4HC-14472-00	PLATE, ELEMENT	1	1	
12	4HC-14452-00	SEAL	1	1	
13	97707-50125	SCREW, TAPPING	7	7	
14	90446-11303	HOSE	1	1	
15	90338-08174	PLUG	1	1	
16	90467-10008	CLIP	2	2	
17	90480-13598	GROMMET	2	2	
18	5GM-1441A-00	COVER, CLEANER CASE 1	1	1	
19	90387-064W3	COLLAR	2	2	
20	90109-067E6	BOLT	2	2	
21	90450-60001	HOSE CLAMP ASSY	1	1	
22	5GM-14294-00	HOSE	1	1	
23	90467-11032	CLIP	2	2	
24	90464-13001	CLAMP	1	1	



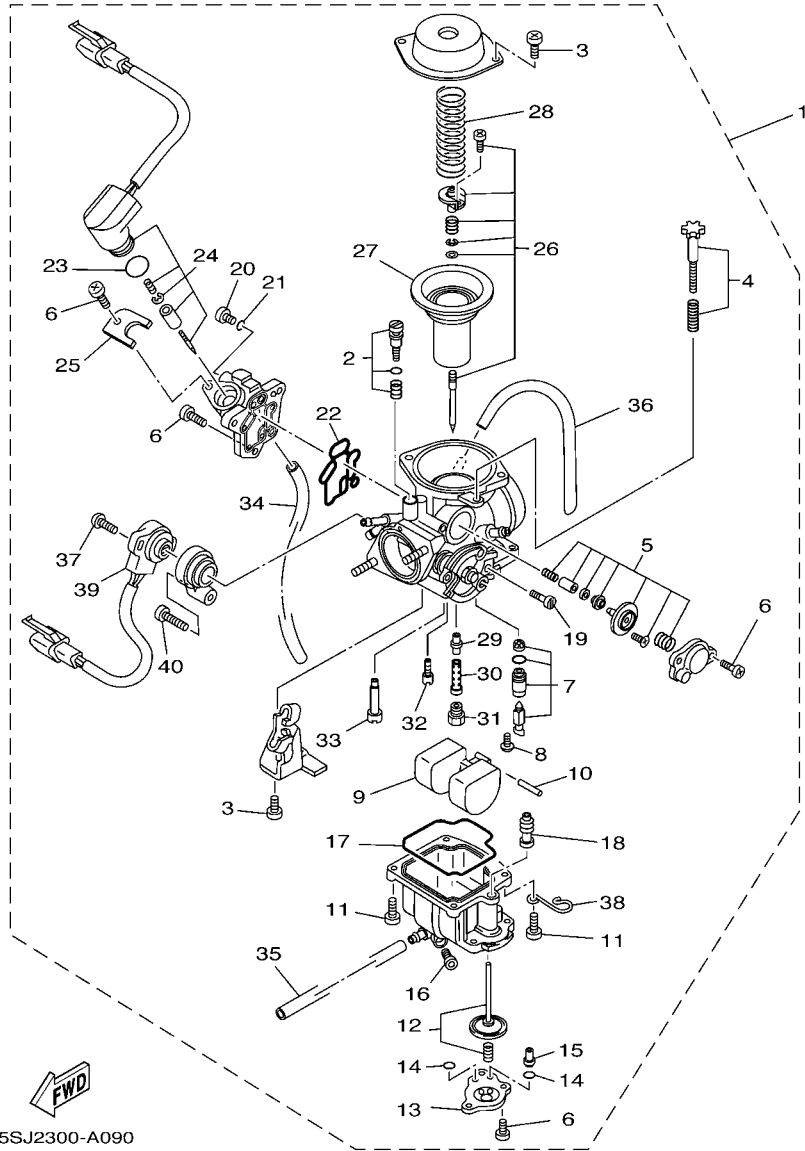

5SJ2300-A090

FIG. 9 CARBURETOR

REF. NO.	PART NO.	DESCRIPTION	5SJB	5SJB	REMARKS
1	5GM-14301-11	CARBURETOR ASSY 1	1	1	
2	5GM-14105-00	.PILOT SCREW SET	1	1	
3	97801-05010	.THROTTLE SCREW	4	4	
4	4HC-14103-00	.THROTTLE SCREW SET	1	1	
5	4HC-1490A-00	.DIAPHRAGM SET 1	1	1	
6	214-24535-00	.SCREW, LEVER FITTING	9	9	
7	4HC-14390-00	.NEEDLE VALVE ASSY	1	1	
8	98901-04006	.SCREW, BIND	1	1	
9	25N-14385-00	.FLOAT	1	1	
10	4KL-14386-00	.PIN, FLOAT	1	1	
11	98501-04012	.SCREW, PAN HEAD	4	4	
12	4HC-1490H-08	.DIAPHRAGM SET 5	1	1	
13	4HC-14958-00	.COVER, DIAPHRAGM	1	1	
14	4HC-14147-00	.O-RING	2	2	
15	4KL-14272-01	.VALVE, CHECK SEAT	1	1	
16	4KL-14115-00	.PLUG, DRAIN	1	1	
17	4KL-14384-00	.GASKET, FLOAT CHAMBER	1	1	
18	4KL-14404-00	.BOOT	1	1	
19	4HC-14429-00	.SCREW	1	1	
20	4HC-14592-00	.SCREW	1	1	
21	5H0-14397-00	.O-RING	1	1	
22	4KL-14536-00	.GASKET	1	1	
23	4KL-14397-00	.O-RING	1	1	
24	5GM-1410A-10	.STARTER SET	1	1	
25	4JP-14243-01	.PLATE	1	1	
26	5GM-1490J-00	.NEEDLE SET	1	1	
27	4HC-14340-01	.VALVE ASSY	1	1	

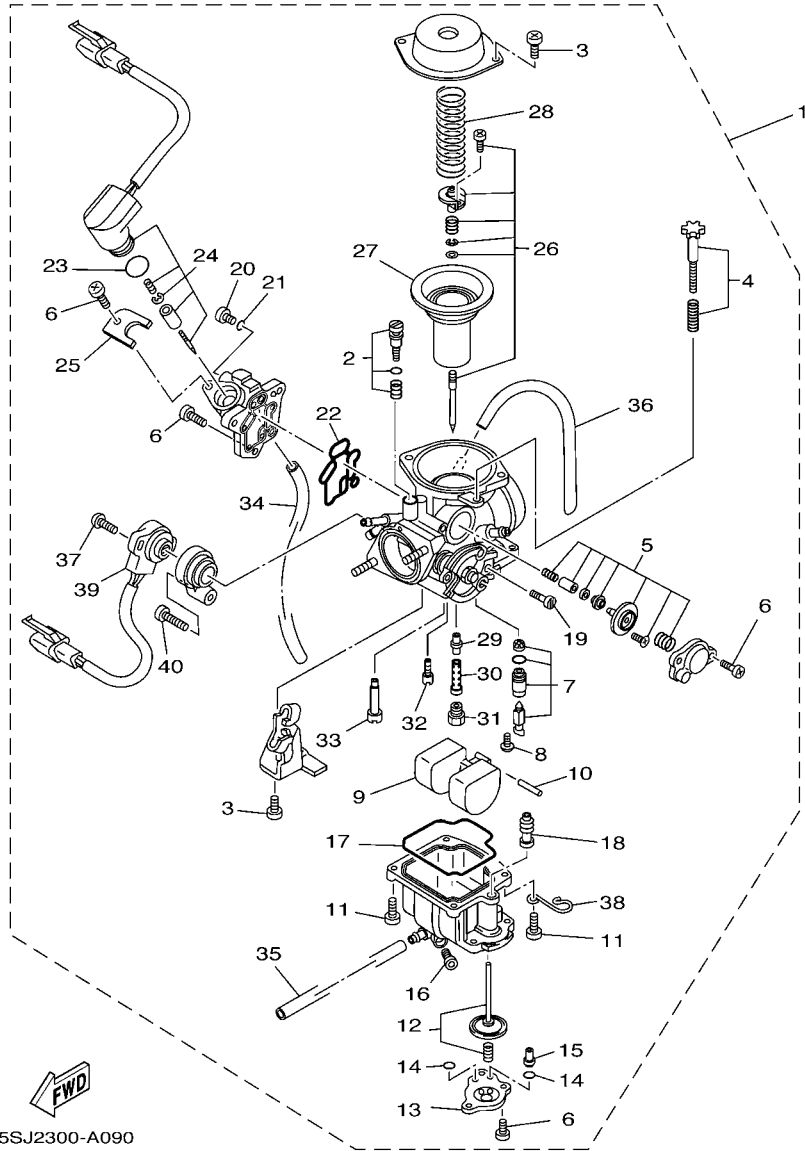

5SJ2300-A090

FIG. 9 CARBURETOR

REF. NO.	PART NO.	DESCRIPTION	5SJB	5SJB	REMARKS
28	4HC-14286-00	.SPRING	1	1	
29	4UC-14341-00	.NOZZLE, MAIN	1	1	
30	4UC-14341-10	.NOZZLE, MAIN	1	1	
31	50M-14343-64	.JET, MAIN (#128)	1	1	
32	38V-14342-71	.JET, PILOT(#43)	1	1	
33	50M-14355-00	.PLUG	1	1	
34	4HC-14197-00	.PIPE	1	1	
35	4HC-14196-00	.PIPE	1	1	
36	5GM-14197-00	.PIPE	1	1	
37	5GM-14565-00	.SCREW	1	1	
38	5GM-14243-00	.CLAMP	1	1	
39	5GM-85885-00	.THROTTLE SENSOR ASSY	1	1	
40	97801-05014	.SCREW, PAN HEAD	1	1	

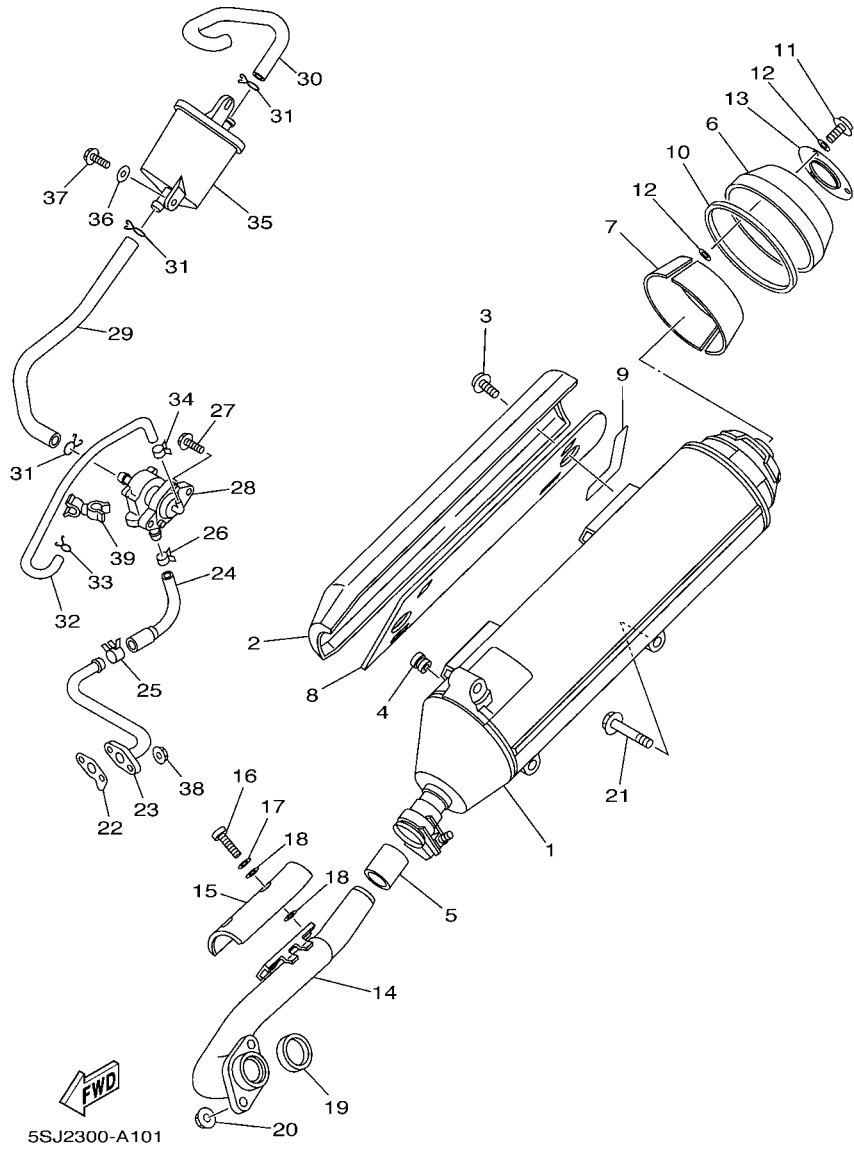

**FIG. 10 EXHAUST**

REF. NO.	PART NO.	DESCRIPTION	5SJB	5SJB	REMARKS
1	5RB-14711-00	MUFFLER 1	1	1	
2	5SJ-14718-00	PROTECTOR, MUFFLER 1	1	1	
3	90111-06015	BOLT	2	2	
4	90480-10332	GROMMET	2	2	
5	4BH-14714-00	GASKET, MUFFLER	1	1	
6	5SJ-14799-00	CAP	1	1	
7	5GM-14728-00	PROTECTOR, MUFFLER 2	2	2	
8	5GM-14738-00	PROTECTOR, MUFFLER 3	1	1	
9	5RB-14758-00	PROTECTOR, SILENCER	1	1	
10	5RB-14748-00	PROTECTOR, MUFFLER 4	1	1	
11	90111-06020	BOLT	3	3	
12	5RB-14766-00	WASHER, PROTECTOR	6	6	
13	5GM-1482K-00	PLATE	1	1	
14	5GM-14611-10	PIPE, EXHAUST 1	1	1	
15	4HC-14628-00	PROTECTOR, EXHAUST PIPE	1	1	
16	92017-06012	BOLT, BUTTON HEAD	2	2	
17	92907-06200	WASHER	2	2	
18	4BD-14766-00	WASHER, PROTECTOR	4	4	
19	3MT-14613-00	GASKET, EXHAUST PIPE	1	1	
20	95607-08200	NUT, SELF-LOCKING	2	2	
21	95817-10050	BOLT, FLANGE	3	3	
22	5GM-14815-00	GASKET	1	1	
23	5GM-14871-01	PIPE 1	1	1	
24	5GM-14881-00	HOSE, BEND 1	1	1	
25	90467-16181	CLIP	1	1	
26	90467-13062	CLIP	1	1	
27	95807-06020	BOLT, FLANGE	2	2	

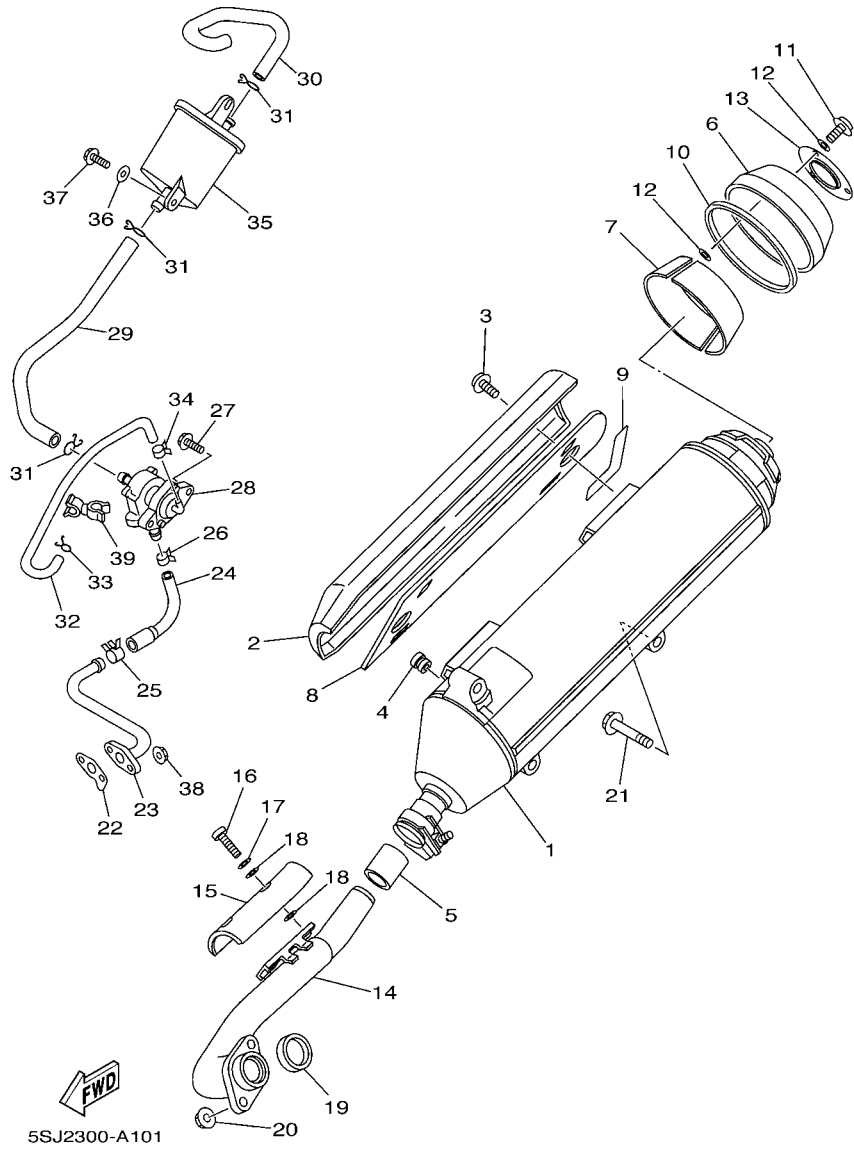

**FIG. 10 EXHAUST**

REF. NO.	PART NO.	DESCRIPTION	5SJB	5SJB	REMARKS
28	5GM-14803-00	AIR INDUCTION SYSTEM ASSY	1	1	
29	5GM-14882-00	HOSE, BEND 2	1	1	
30	5GM-14883-00	HOSE, BEND 3	1	1	
31	90467-16195	CLIP	3	3	
32	5GM-13542-00	HOSE, VACUUM SENSING 1	1	1	
33	90467-09006	CLIP	1	1	
34	90467-07138	CLIP	1	1	
35	5GM-14806-00	AIR FILTER	1	1	
36	90201-06380	WASHER, PLATE	2	2	
37	95807-06014	BOLT, FLANGE	2	2	
38	95607-06200	NUT, SELF U-FLANGE	2	2	
39	90464-11004	CLAMP	1	1	

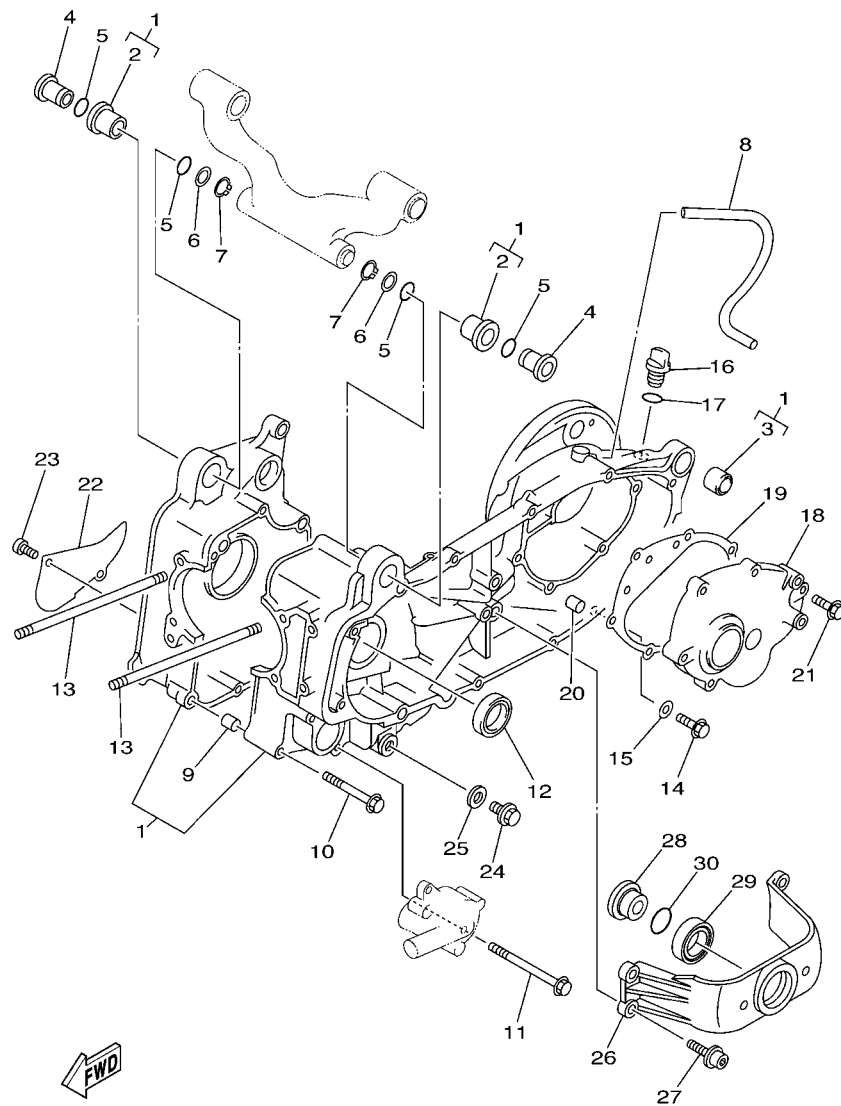

5GM1010-0111

FIG. 11 CRANKCASE

REF. NO.	PART NO.	DESCRIPTION	SSJ9	SSJ8	REMARKS
1	5GM-15100-00	CRANKCASE ASSY	1	1	
2	4HC-15378-00	.HOLDER	2	2	
3	164-22216-00	.BUSH, REAR SHOCK ABSORBER	1	1	
4	90387-1006J	COLLAR	2	2	
5	93210-16275	O-RING	4	4	
6	90201-16242	WASHER, PLATE	2	2	
7	99009-16400	CIRCLIP	2	2	
8	90445-135J8	HOSE (L330)	1	1	
9	99530-10114	PIN, DOWEL	2	2	
10	95027-06070	BOLT, FLANGE	4	4	
11	95027-06100	BOLT, FLANGE	5	5	
12	93102-30284	OIL SEAL	1	1	
13	90116-08591	BOLT, STUD	4	4	
14	95817-08016	BOLT, FLANGE	1	1	
15	90430-08119	GASKET	1	1	
16	2T4-15363-00	PLUG, OIL	1	1	
17	93210-14104	O-RING	1	1	
18	5GM-15421-00	COVER, CRANKCASE 2	1	1	
19	4HC-15461-00	GASKET, CRANKCASE COVER 2	1	1	
20	99530-10114	PIN, DOWEL	2	2	
21	95027-08040	BOLT, FLANGE	6	6	
22	4HC-15492-00	COVER	1	1	
23	91317-06014	BOLT	2	2	
24	90340-12059	PLUG, STRAIGHT SCREW	1	1	
25	90430-12213	GASKET	1	1	
26	5GM-15199-00	BRACKET	1	1	
27	90109-082F5	BOLT	4	4	

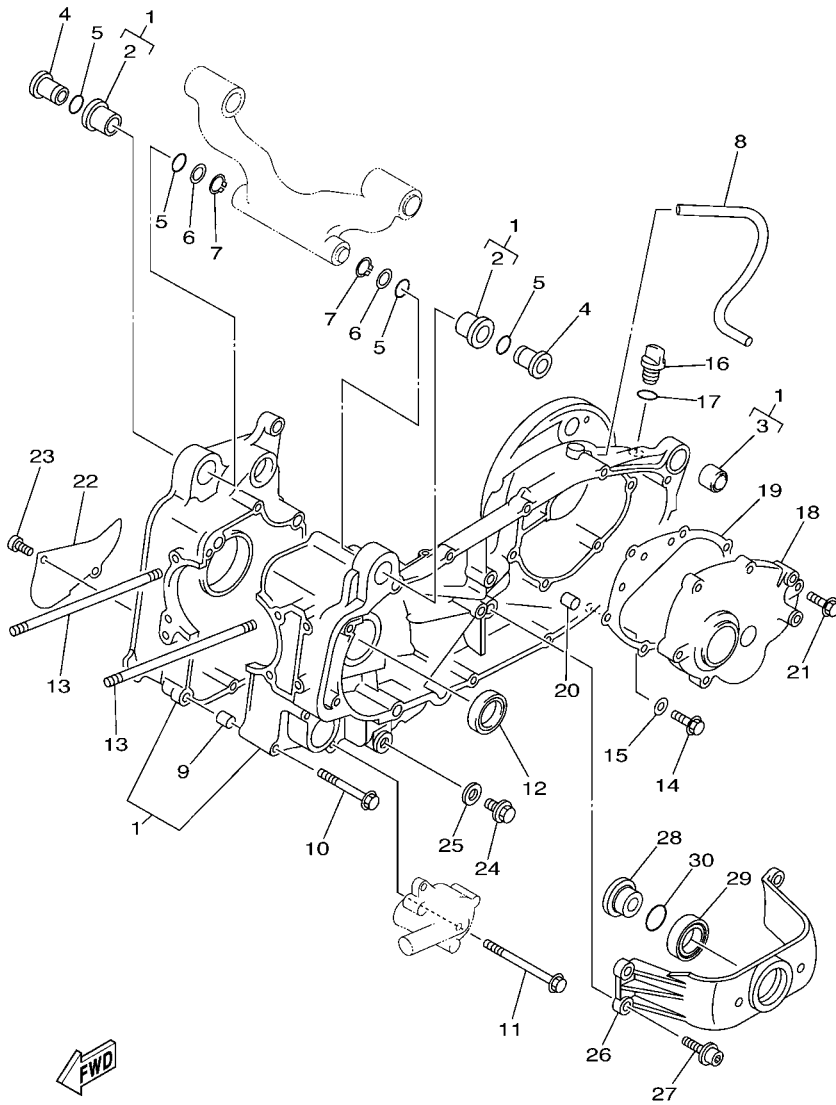

5GM1010-0111

FIG. 11 CRANKCASE

REF. NO.	PART NO.	DESCRIPTION	SSJ9	SSJ8		REMARKS
28	5GM-17649-00	SPACER	1	1		
29	93306-90603	BEARING	1	1		
30	93210-27672	O-RING	1	1		

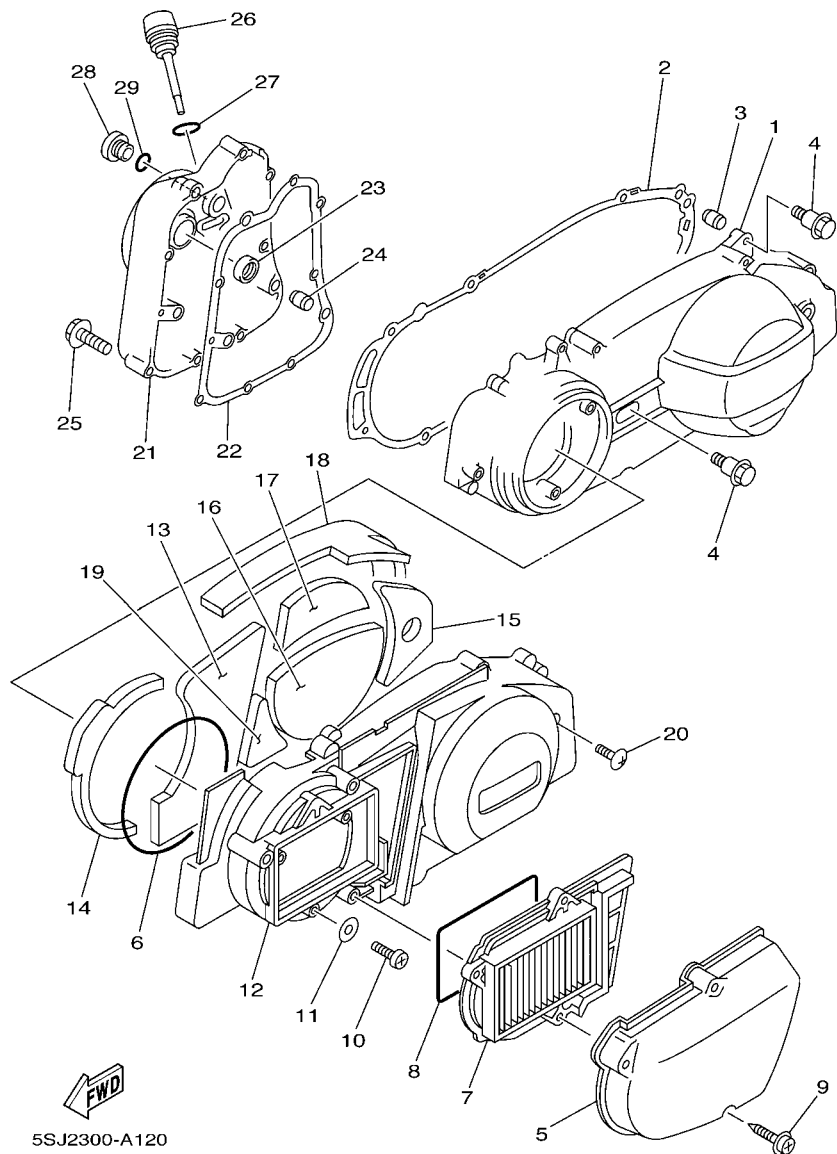

FIG. 12 CRANKCASE COVER 1

REF. NO.	PART NO.	DESCRIPTION	5S-J9	5S-JB	REMARKS
1	5GM-15411-00	COVER, CRANKCASE 1	1	1	
2	5GM-15451-00	GASKET, CRANKCASE COVER 1	1	1	
3	99530-10114	PIN, DOWEL	2	2	
4	90109-06030	BOLT	8	8	
5	5GM-15471-00	DUCT, AIR	1	1	
6	4HC-15472-00	SEAL, AIR DUCT	1	1	
7	5GM-15407-00	ELEMENT 1	1	1	
8	17W-14462-00	SEAL	1	1	
9	90167-05003	SCREW, TAPPING	3	3	
10	98507-06020	SCREW, PAN HEAD	3	3	
11	92907-06600	WASHER, PLATE	3	3	
12	5GM-15431-00	COVER, CRANKCASE 3	1	1	
13	5GM-15316-00	DAMPER, ENGINE MOUNT 1	1	1	
14	5GM-15326-00	DAMPER, ENGINE MOUNT 2	1	1	
15	5GM-15335-00	DAMPER 3	1	1	
16	5GM-15337-00	DAMPER 4	1	1	
17	5GM-15338-00	DAMPER, ENGINE MOUNT 5	1	1	
18	5GM-15491-00	PROTECTOR	1	1	
19	5GM-15499-00	PROTECTOR, COVER	1	1	
20	3KJ-15481-00	BOLT 1	1	1	
21	5GM-15417-00	COVER, CAP	1	1	
22	4HC-15453-00	GASKET	1	1	
23	93101-14092	OIL SEAL (S7-14-25-5.5-1-HS)	1	1	
24	99530-10114	PIN, DOWEL	2	2	
25	95027-06040	BOLT, FLANGE	10	10	
26	4HC-15363-00	PLUG, OIL	1	1	
27	93210-19123	O-RING	1	1	

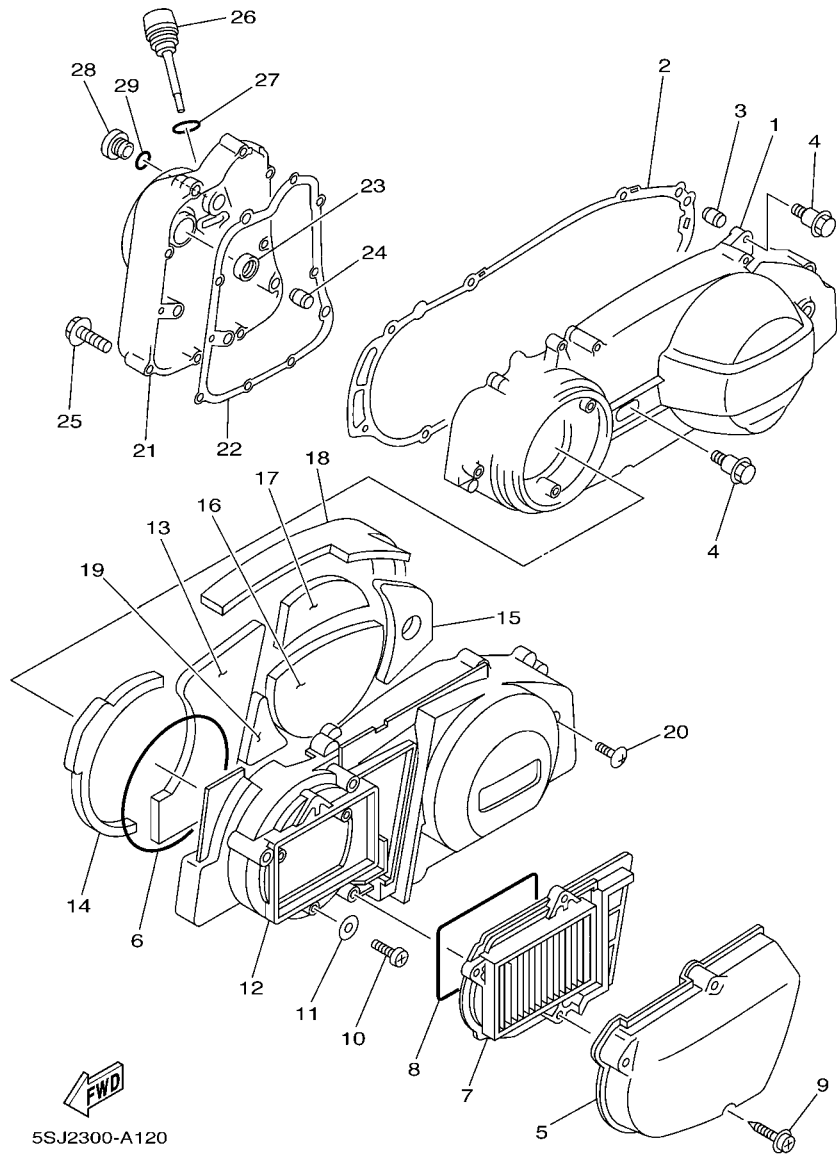
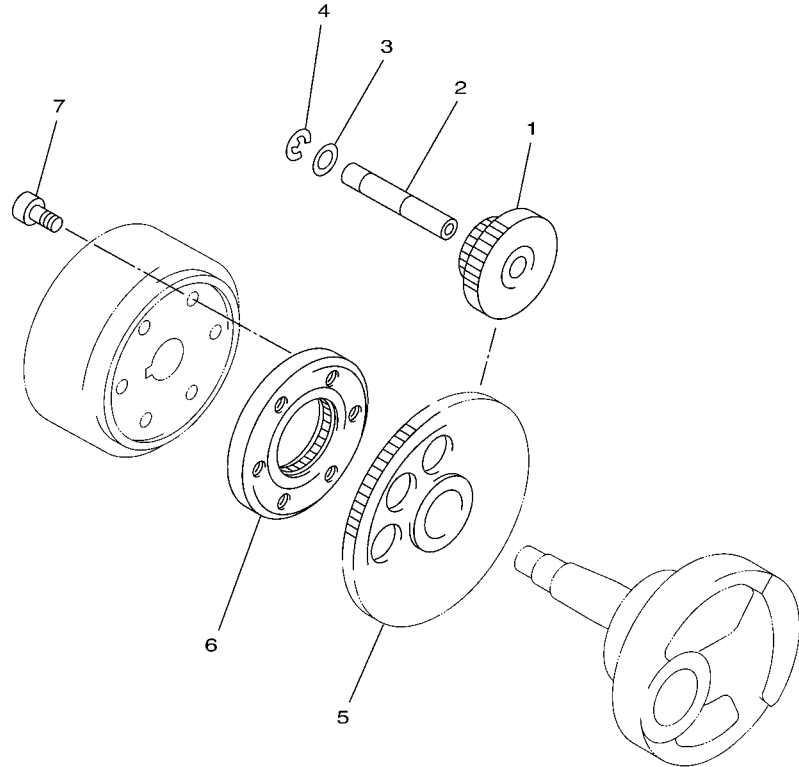

FIG. 12 CRANKCASE COVER 1

REF. NO.	PART NO.	DESCRIPTION	5SJB	5SJB		REMARKS
28	36Y-15189-00	PLUG	1	1		
29	93210-16325	O-RING	1	1		

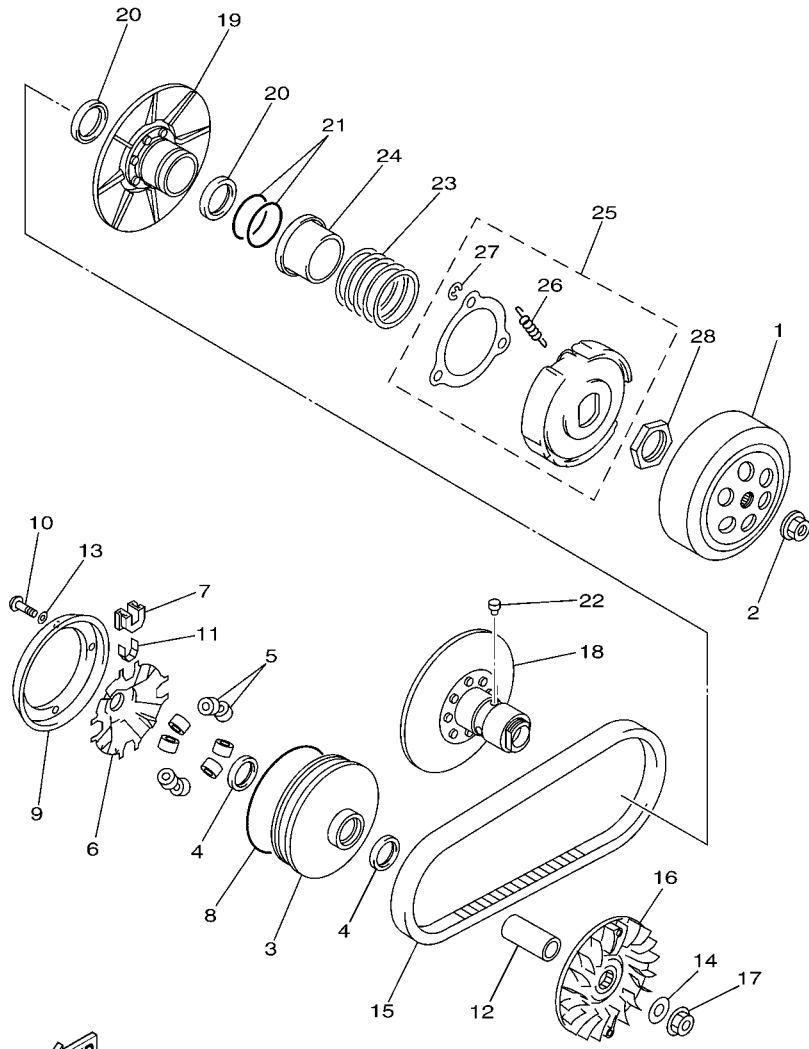

**FIG. 13 STARTER**



REF. NO.	PART NO.	DESCRIPTION	SSJ9	SSJ8		REMARKS
1	4HC-15512-00	GEAR, IDLER 1	1	1		
2	2HT-15521-00	SHAFT 1	1	1		
3	90201-12166	WASHER, PLATE	1	1		
4	99009-12400	CIRCLIP	1	1		
5	4HC-15517-00	GEAR, IDLER 2	1	1		
6	4HC-15590-00	STARTER ONE-WAY ASSY	1	1		
7	91317-08016	BOLT	3	3		

  
4HC1010-5130



**FWD**  
5GM1010-0140

**FIG. 14 CLUTCH**

REF. NO.	PART NO.	DESCRIPTION	SSJ9	SSJ8	REMARKS
1	5GM-16611-00	CLUTCH HOUSING COMP.	1	1	
2	90179-14469	NUT	1	1	
3	5GM-17620-00	PRIMARY SLIDING SHEAVE COMP.	1	1	
4	93101-28139	OIL SEAL	2	2	
5	4CW-17632-01	WEIGHT	8	8	
6	4HC-17623-00	CAM	1	1	
7	4HC-17653-00	SLIDER	4	4	
8	93211-17733	O-RING	1	1	
9	5CG-17639-00	STOPPER	1	1	
10	90157-04088	SCREW, PAN HEAD	4	4	
11	4HC-17654-00	SPACER 1	4	4	
12	90387-1906E	COLLAR	1	1	
13	90201-047R9	WASHER, PLATE	4	4	
14	90201-144M8	WASHER, PLATE	1	1	
15	5CG-17641-00	V-BELT	1	1	
16	4HC-17611-00	SHEAVE, PRIMARY FIXED	1	1	
17	90179-14469	NUT	1	1	
18	5GM-17660-00	SECONDARY FIXED SHEAVE COMP.	1	1	
19	4HC-17670-10	SECONDARY SLIDING SHEAVE	1	1	
20	93104-41119	OIL SEAL	2	2	
21	93210-43713	O-RING	2	2	
22	4CW-17664-00	PIN, GUIDE	4	4	
23	90501-505J6	SPRING, COMPRESSION	1	1	
24	5GM-17644-00	SEAT, SPRING	1	1	
25	5GM-16620-00	CLUTCH CARRIER ASSY	1	1	
26	5KD-16626-10	.SPRING, CLUTCH WEIGHT 1	3	3	
27	99001-08600	.CIRCLIP	3	3	

FIG. 14 CLUTCH

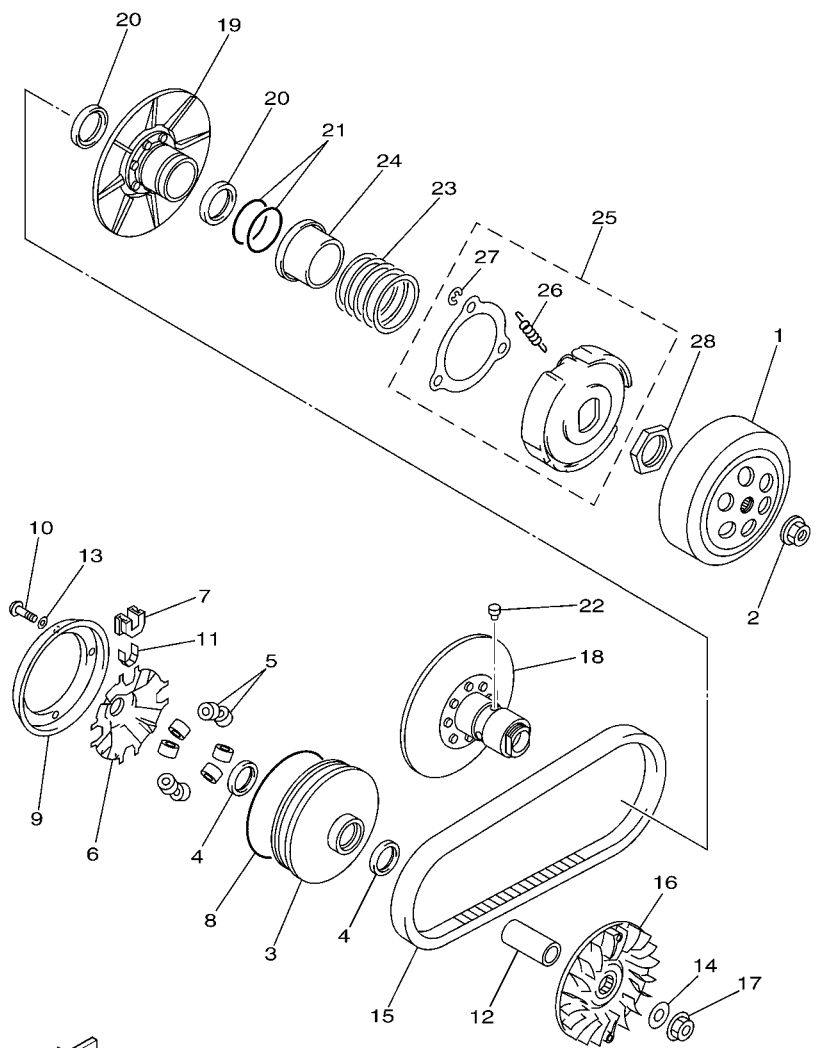

  
5GM1010-0140

REF. NO.	PART NO.	DESCRIPTION	SSJ9	SSJ8		REMARKS
28	90170-36279	NUT	1	1		

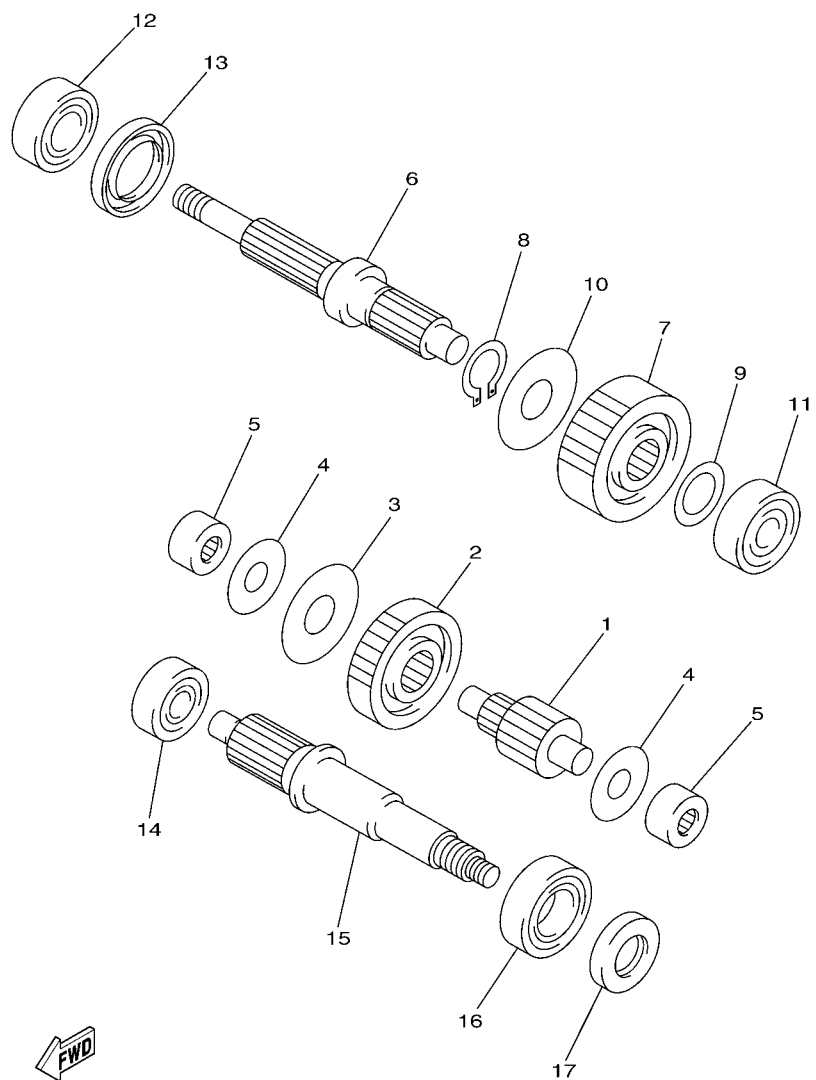

**FWD**  
5GM1010-0150

**FIG. 15 TRANSMISSION**

REF. NO.	PART NO.	DESCRIPTION	SS,JB	SS,JB	REMARKS
1	5GM-17411-00	AXLE, MAIN	1	1	
2	5GM-16151-00	GEAR, PRIMARY DRIVEN (15T)	1	1	
3	90208-21001	WASHER, CONICAL SPRING	1	1	
4	90201-156R4	WASHER, PLATE	2	2	
5	93311-41566	BEARING	2	2	
6	5GM-17421-00	AXLE, DRIVE	1	1	
7	5GM-17211-00	GEAR, 1ST WHEEL (34T)	1	1	
8	99009-25400	CIRCLIP	1	1	
9	90201-232K5	WASHER, PLATE	1	1	
10	90208-25001	WASHER, CONICAL SPRING	1	1	
11	93306-30321	BEARING	1	1	
12	93306-27205	BEARING	1	1	
13	93102-32298	OIL SEAL	1	1	
14	93306-30201	BEARING (B6302)	1	1	
15	5GM-16111-00	GEAR, PRIMARY DRIVE (15T)	1	1	
16	93306-20570	BEARING	1	1	
17	93102-25299	OIL SEAL	1	1	

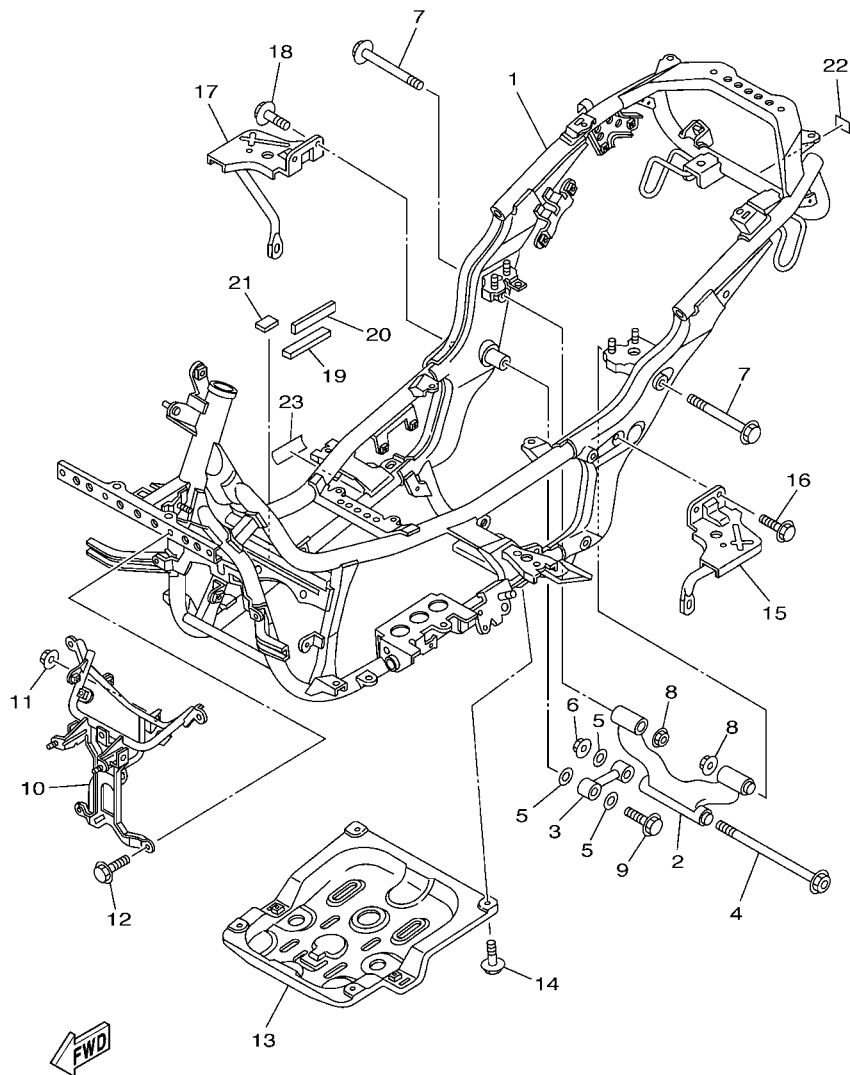

5SJ5300-B160

FIG. 16 FRAME

REF. NO.	PART NO.	DESCRIPTION	5SJB	5SJB	REMARKS
1	5GM-21110-02	FRAME COMP.	1	1	
2	5CG-21420-01	ENGINE BRACKET COMP. 2	1	1	
3	4HC-21480-00	STAY, ENGINE	1	1	
4	90105-10023	BOLT, FLANGE	1	1	
5	90201-105A2	WASHER, PLATE	3	3	
6	90185-10154	NUT, SELF-LOCKING	1	1	
7	95817-12120	BOLT, FLANGE	2	2	
8	90185-12072	NUT, SELF-LOCKING	2	2	
9	95817-10045	BOLT, FLANGE	1	1	
10	5SJ-28356-10	STAY 1	1	1	
11	95707-08500	NUT, FLANGE	1	1	
12	95807-08016	BOLT, FLANGE	2	2	
13	5GM-21417-00	BRACKET, FRONT LOWER 1	1	1	
14	95807-08016	BOLT, FLANGE	4	4	
15	5GM-27452-00	BRACKET, FOOTREST 1	1	1	
16	95807-06012	BOLT, FLANGE	3	3	
17	5GM-27462-00	BRACKET, FOOTREST 2	1	1	
18	95807-06012	BOLT, FLANGE	3	3	
19	5GM-27415-00	PLATE DAMPER	1	1	
20	5GM-27424-00	DAMPER, FOOTREST 2	1	1	
21	5GM-27445-00	PLATE 1	1	1	
22	1UF-15379-00	SEAL, CRANKCASE	1	1	
23	3HA-24141-00	PROTECTOR, FUEL TANK	1	1	

FIG. 17 FENDER

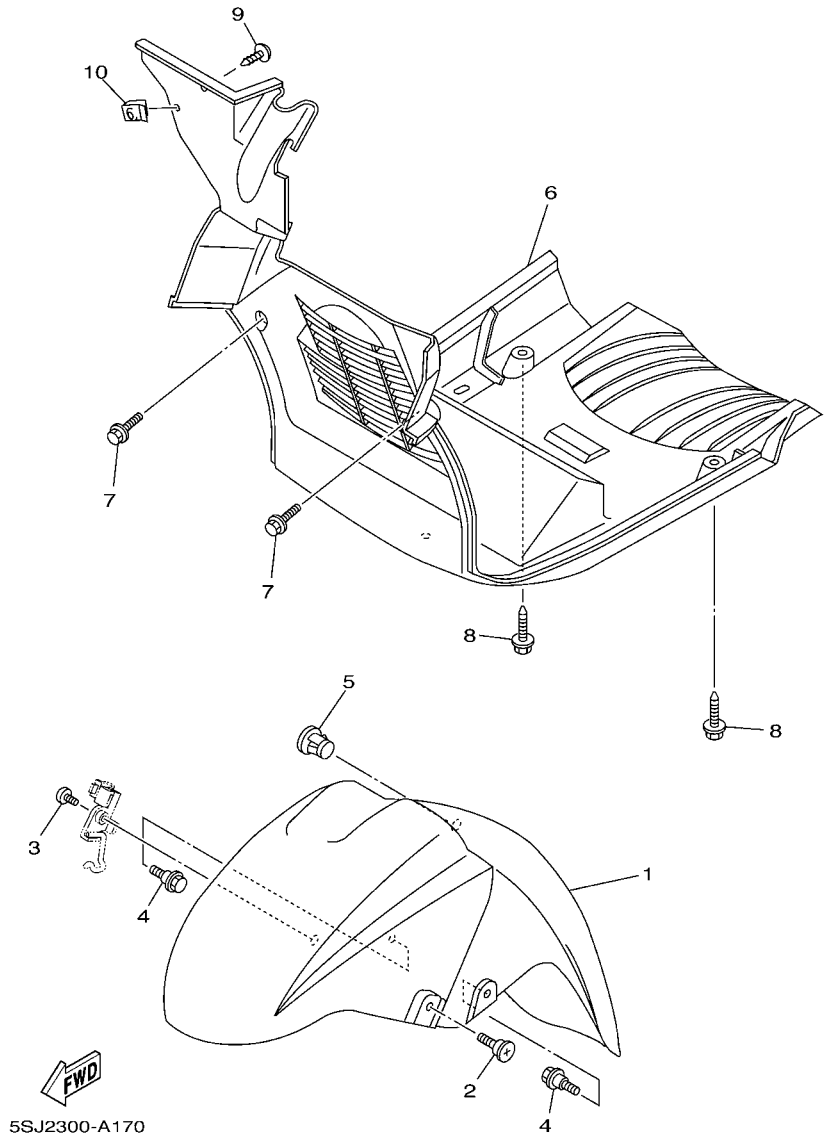

REF. NO.	PART NO.	DESCRIPTION	SSJ9	SSJ8		REMARKS
1	4HC-21511-01-0L	FENDER, FRONT	1	1		UR MAS
	4HC-21511-01-PH	FENDER, FRONT	1	1		UR DRMD
	4HC-21511-01-PM	FENDER, FRONT	1	1		UR DNBME
	4HC-21511-01-PN	FENDER, FRONT	1			UR DNMA
2	90154-06014	SCREW, BINDING	1	1		
3	90149-06184	SCREW, BINDING	1	1		
4	90109-060F3	BOLT	2	2		
5	5CG-21279-00	PLUG, BLIND	1	1		
6	5GM-21552-00	FENDER, INNER	1	1		
7	90119-06044	BOLT, WITH WASHER	2	2		
8	90119-06060	BOLT, WITH WASHER	2	2		
9	97707-50016	SCREW, TAPPING	1	1		
10	90183-05042	NUT, SPRING	1	1		

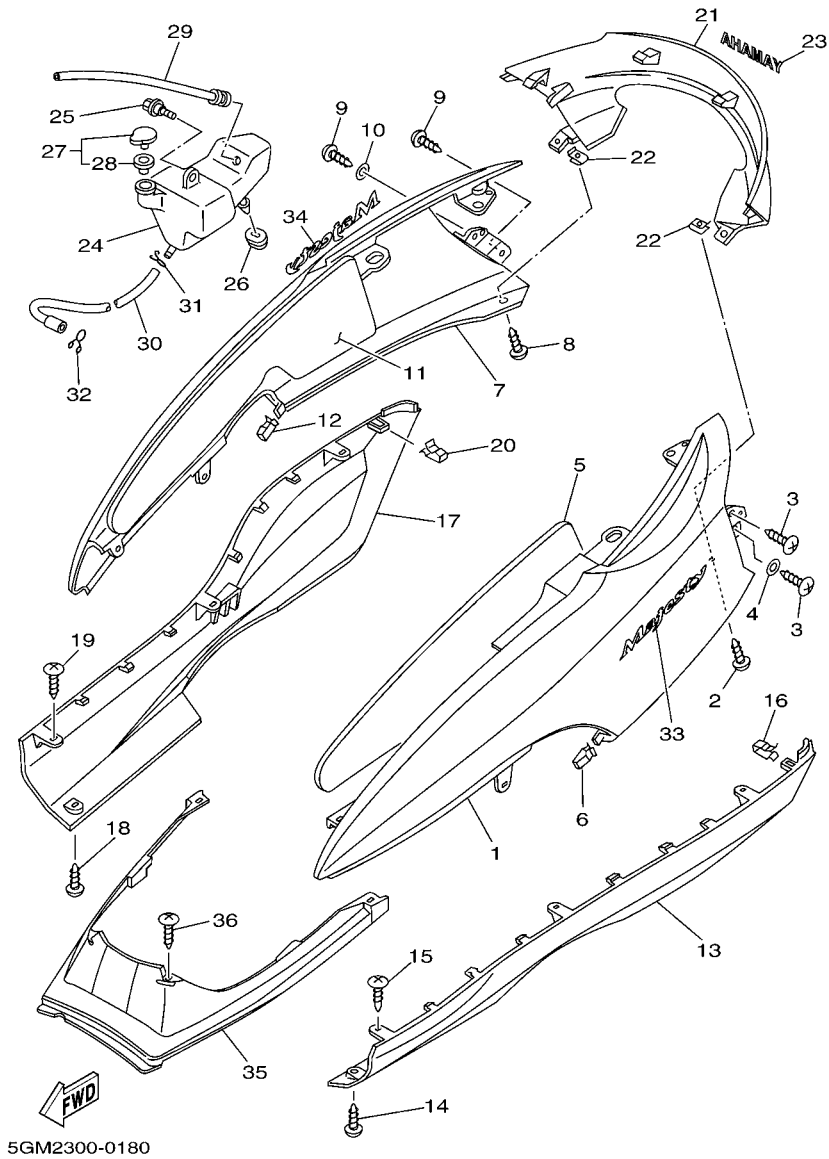

FIG. 18 SIDE COVER

REF. NO.	PART NO.	DESCRIPTION	SSJG	SSJB	REMARKS
1	5GM-21711-01-0L	COVER, SIDE 1	1	1	UR MAS
	5GM-21711-01-P8	COVER, SIDE 1	1	1	UR DRMD
	5GM-21711-01-PC	COVER, SIDE 1	1	1	UR DNBME
	5GM-21711-01-PD	COVER, SIDE 1	1		UR DNMA
2	90167-05079	SCREW, TAPPING	2	2	
3	97707-50012	SCREW, TAPPING	4	4	
4	90201-05725	WASHER, PLATE	1	1	
5	5GM-21778-00	DAMPER, LOCATING 1	1	1	
6	5GM-28379-00	HOOK	1	1	
7	5GM-21721-01-0L	COVER, SIDE 2	1	1	UR MAS
	5GM-21721-01-P8	COVER, SIDE 2	1	1	UR DRMD
	5GM-21721-01-PC	COVER, SIDE 2	1	1	UR DNBME
	5GM-21721-01-PD	COVER, SIDE 2	1		UR DNMA
8	90167-05079	SCREW, TAPPING	2	2	
9	97707-50012	SCREW, TAPPING	4	4	
10	90201-05725	WASHER, PLATE	1	1	
11	5GM-21779-00	DAMPER, LOCATING 2	1	1	
12	5GM-28379-00	HOOK	1	1	
13	5GM-2171L-00-0L	MOLE, SIDE COVER 1	1	1	UR MAS
	5GM-2171L-00-P8	MOLE, SIDE COVER 1	1	1	UR DRMD
	5GM-2171L-00-PC	MOLE, SIDE COVER 1	1	1	UR DNBME
	5GM-2171L-00-PD	MOLE, SIDE COVER 1	1		UR DNMA
14	97707-50016	SCREW, TAPPING	1	1	
15	97707-50012	SCREW, TAPPING	3	3	
16	5GM-28379-00	HOOK	1	1	
17	5GM-2171M-00-0L	MOLE, SIDE COVER 2	1	1	UR MAS
	5GM-2171M-00-P8	MOLE, SIDE COVER 2	1	1	UR DRMD

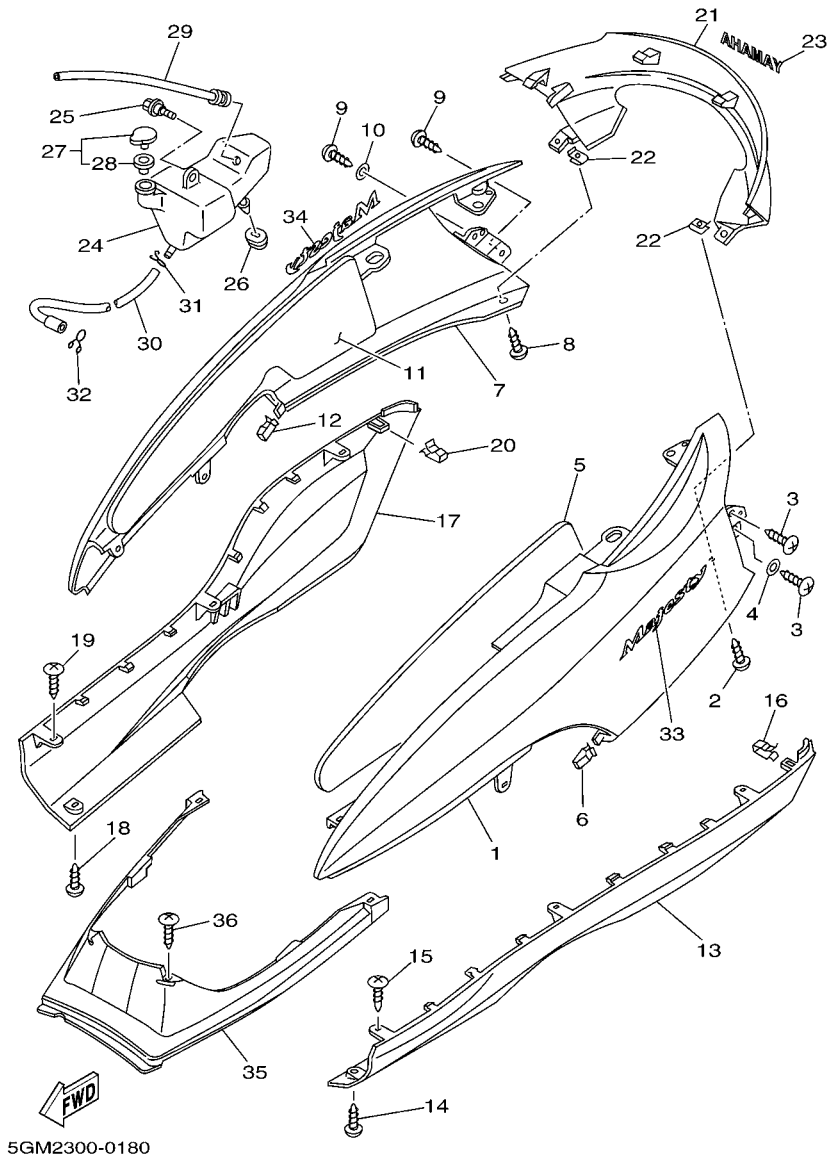
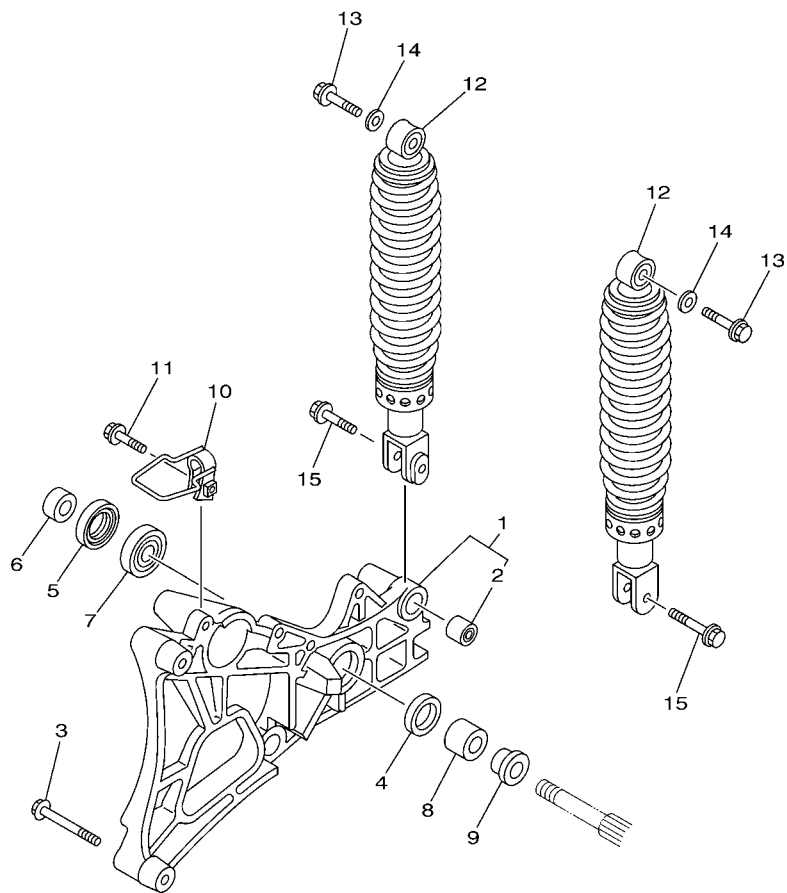

FIG. 18 SIDE COVER

REF. NO.	PART NO.	DESCRIPTION	SSJ9	SSJ8		REMARKS
17	5GM-2171M-00-PC	MOLE, SIDE COVER 2	1	1		UR DNBME
	5GM-2171M-00-PD	MOLE, SIDE COVER 2	1			UR DNMA
18	97707-50016	SCREW, TAPPING	1	1		
19	97707-50012	SCREW, TAPPING	3	3		
20	5GM-28379-00	HOOK	1	1		
21	5GM-2171N-00-0L	MOLE, SIDE COVER 3	1	1		UR MAS
	5GM-2171N-00-P8	MOLE, SIDE COVER 3	1	1		UR DRMD
	5GM-2171N-00-PC	MOLE, SIDE COVER 3	1	1		UR DNBME
	5GM-2171N-00-PD	MOLE, SIDE COVER 3	1			UR DNMA
22	90183-05042	NUT, SPRING	2	2		
23	99247-00080	EMBLEM, YAMAHA	1	1		UR MAS,DRMD
	99246-00080	EMBLEM, YAMAHA	1	1		UR DNBME,DNMA
24	5GM-21871-00	TANK, RECOVERY	1	1		
25	90109-063F1	BOLT	1	1		
26	90480-01288	GROMMET	1	1		
27	1AA-21815-00	CAP	1	1		
28	1AA-21874-00	.GASKET	1	1		
29	5GM-21816-00	PIPE 1	1	1		
30	5GM-21817-00	PIPE 2	1	1		
31	90467-08003	CLIP	1	1		
32	90467-10008	CLIP	1	1		
33	5GM-2173B-00	EMBLEM	1	1		
34	5GM-2173B-00	EMBLEM	1	1		
35	5GM-21731-00	COVER, SIDE 3	1	1		
36	97707-50016	SCREW, TAPPING	4	4		

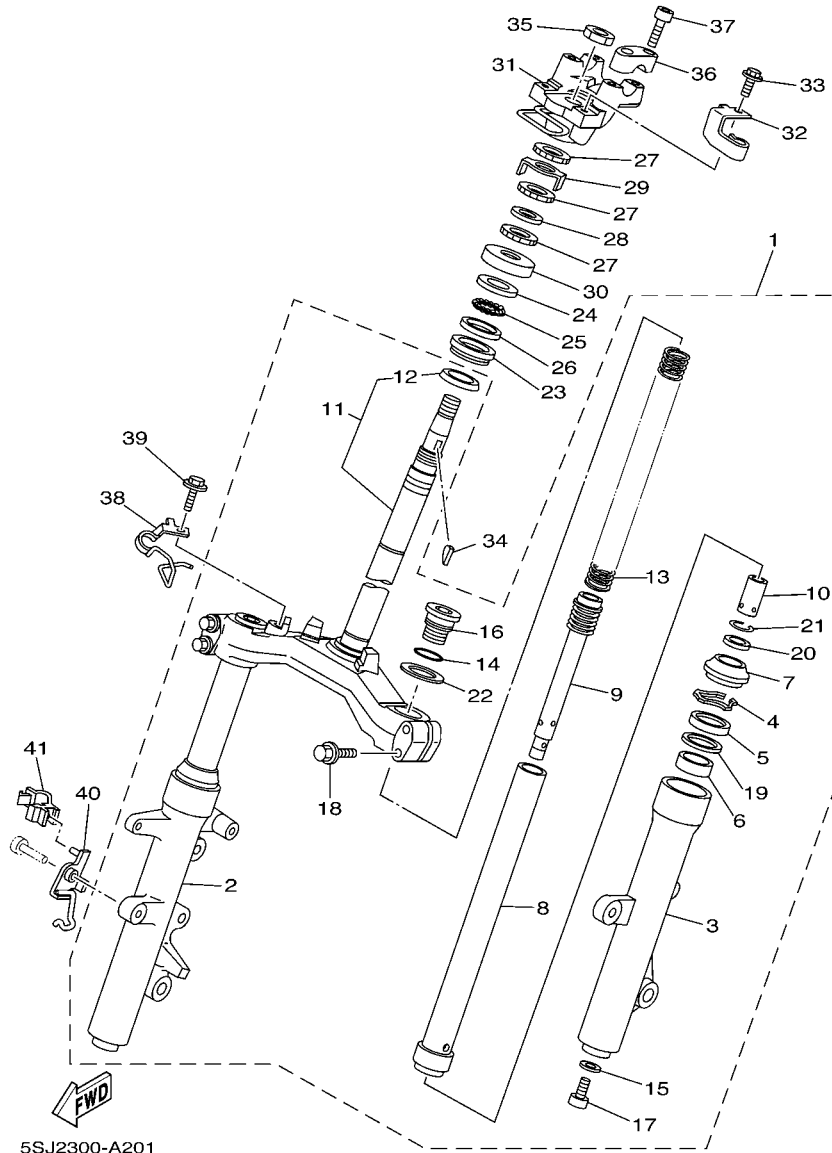

**FIG. 19 REAR ARM. SUSPENSION**



REF. NO.	PART NO.	DESCRIPTION	SSJ9	SSJ8		REMARKS
1	5GM-22100-00	REAR ARM ASSY	1	1		
2	164-22216-00	.BUSH, REAR SHOCK ABSORBER	1	1		
3	95817-08070	BOLT, FLANGE	2	2		
4	93109-28043	OIL SEAL	1	1		
5	93106-26005	OIL SEAL	1	1		
6	90387-15423	COLLAR	1	1		
7	93306-30212	BEARING	1	1		
8	90387-154E1	COLLAR	1	1		
9	90387-155F2	COLLAR	1	1		
10	5GM-25875-00	HOLDER, BRAKE HOSE 1	1	1		
11	95807-06025	BOLT, FLANGE	1	1		
12	5GM-22210-00	SHOCK ABSORBER ASSY, REAR	2			
	5SJ-22210-00	SHOCK ABSORBER ASSY, REAR		2		
13	95827-10035	BOLT, FLANGE	2	2		
14	90201-105A2	WASHER, PLATE	2	2		
15	95827-08030	BOLT, FLANGE	2	2		

  
5GM1010-0190



5SJ2300-A201

FIG. 20 STEERING

REF. NO.	PART NO.	DESCRIPTION	5S:J9	5S:J8		REMARKS
1	5GM-23100-01	FRONT FORK ASSY	1			
	5SJ-23100-00	FRONT FORK ASSY		1		
2	4HC-23136-11	.TUBE, OUTER (RIGHT)	1	1		
3	4HC-23126-10	.TUBE, OUTER (LEFT)	1	1		
4	22W-23153-L0	.RING, SNAP	2	2		
5	2UJ-23145-00	.OIL SEAL	2	2		
6	4HC-23125-20	.METAL, SLIDE 1	2	2		
7	2UJ-23144-00	.SEAL, DUST	2	2		
8	5GM-23110-00	.INNER TUBE COMP.1	2	2		
9	5GM-23170-00	.CYLINDER COMP., FRONT FORK	2			
	5SJ-23170-00	.CYLINDER COMP., FRONT FORK		2		
10	4HC-23173-20	.SPINDLE, TAPER	2	2		
11	5GM-23340-01	.UNDER BRACKET COMP.	1	1		
12	164-23462-00	..SEAL, STEERING	1	1		
13	5GM-23141-00	.SPRING, FRONT FORK	2	2		
14	3J2-23114-00	.O-RING	2	2		
15	509-23158-L0	.GASKET	2	2		
16	5RB-23111-00	.BOLT, CAP	2	2		
17	278-23181-50	.BOLT, HEXAGON SOCKET HEAD	2	2		
18	95027-08040	.BOLT, FLANGE	4	4		
19	22W-23146-L0	.WASHER, OIL SEAL	2	2		
20	4HC-23184-10	.CAP, AIR VALVE	2	2		
21	3G2-23183-00	.RING, SNAP	2	2		
22	3DM-23149-10	.WASHER, SPRING UPPER	2	2		
23	93399-99942	BEARING	1	1		
24	22F-23411-01	RACE, BALL 1	1	1		
25	22F-2341E-00	RETAINER, BALL BEARING	1	1		

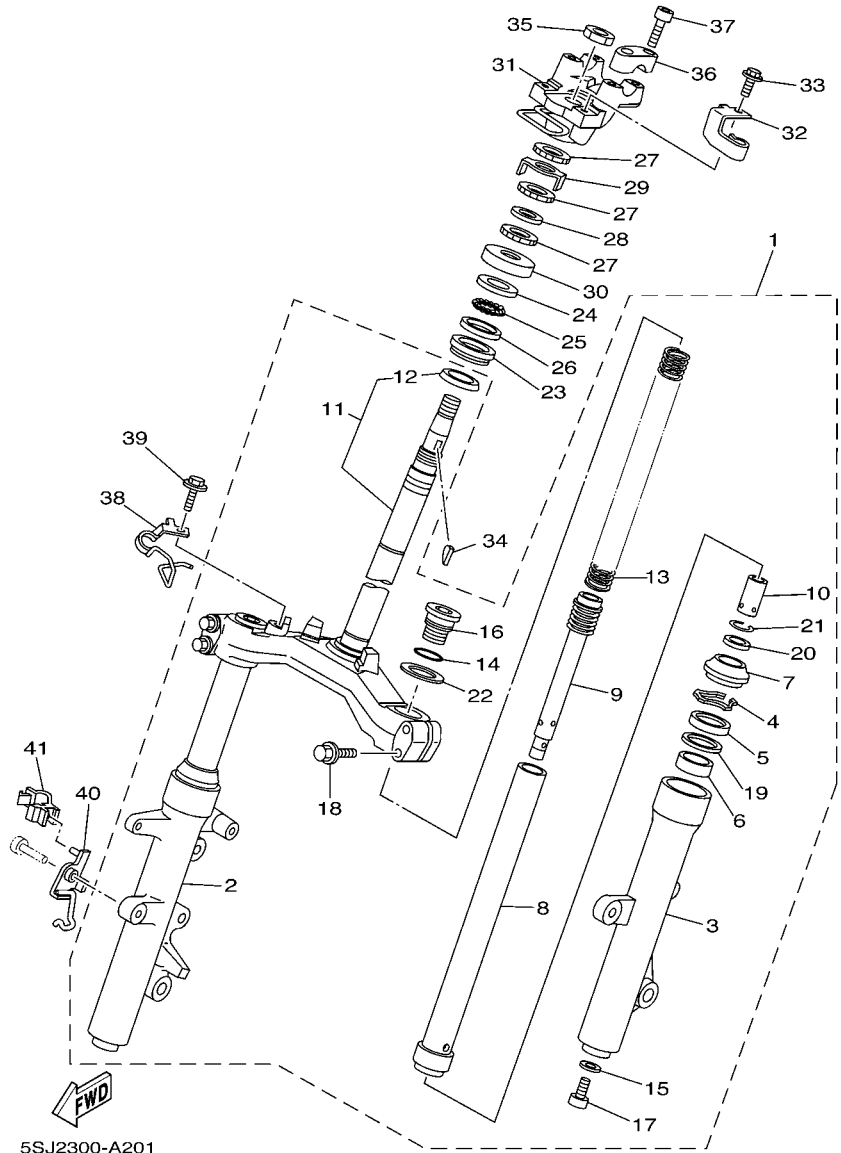

5SJ2300-A201

FIG. 20 STEERING

REF. NO.	PART NO.	DESCRIPTION	5S:J9	5S:J8		REMARKS
26	22F-23412-01	RACE, BALL 2	1	1		
27	90179-25615	NUT	3	3		
28	90202-26142	WASHER, PLATE	1	1		
29	3YF-23418-00	WASHER, SPECIAL	1	1		
30	3VP-23416-00	COVER, BALL RACE 2	1	1		
31	5SJ-23442-00	HOLDER, HANDLE LOWER	1	1		
32	5SJ-25887-00	HOLDER, BRAKE HOSE	1	1		
33	90105-05002	BOLT, FLANGE	1	1		
34	90280-03017	KEY, WOODRUFF	1	1		
35	90170-20386	NUT	1	1		
36	4H7-23441-10	HOLDER, HANDLE UPPER	2	2		
37	91317-08030	BOLT	4	4		
38	4HC-25875-01	HOLDER, BRAKE HOSE 1	1	1		
39	95807-06012	BOLT, FLANGE	1	1		
40	5RB-23317-00	HOLDER, CABLE	1	1		
41	90464-05188	CLAMP	1	1		

FIG. 21 FUEL TANK

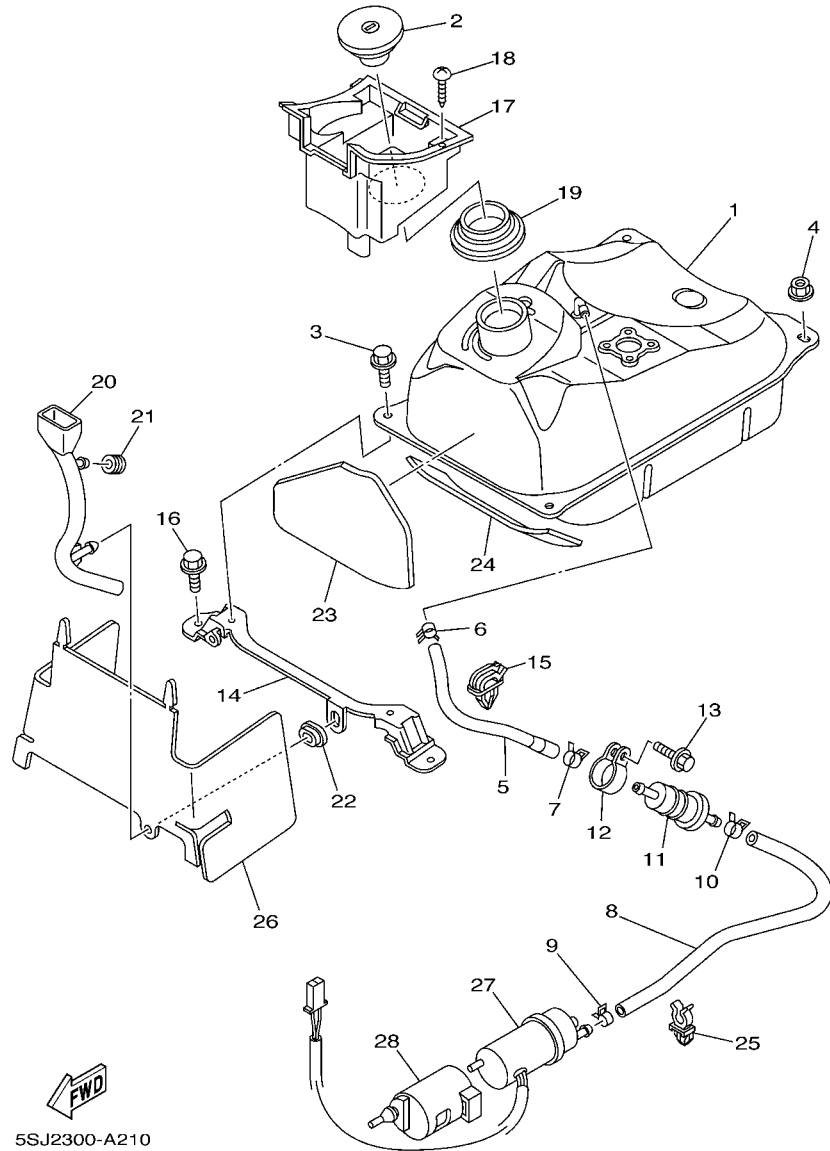

5SJ2300-A210

REF. NO.	PART NO.	DESCRIPTION	5S:J9	5S:J8		REMARKS
1	5GM-24110-11	FUEL TANK COMP.	1	1		
2	3KJ-24602-03	CAP ASSY	1	1		
3	95827-06012	BOLT, FLANGE	2	2		
4	95707-06500	NUT, FLANGE	2	2		
5	5GM-24311-00	PIPE, FUEL 1	1	1		
6	90467-10038	CLIP	1	1		
7	90467-12053	CLIP	1	1		
8	5GM-24312-00	PIPE 2	1	1		
9	90467-10038	CLIP	1	1		
10	90467-12053	CLIP	1	1		
11	1FK-24560-10	FILTER ASSY	1	1		
12	1AE-24366-00	CLAMP, FUEL PIPE 1	1	1		
13	95027-06012	BOLT, FLANGE	1	1		
14	5GM-24191-00	BRACKET, FUEL TANK 1	1	1		
15	90464-07001	CLAMP	1	1		
16	95827-06012	BOLT, FLANGE	2	2		
17	5GM-2414A-00	COVER, FILLER	1	1		
18	97707-50012	SCREW, TAPPING	2	2		
19	5GM-2414G-00	SEAL	1	1		
20	5GM-24667-00	GUIDE, PIPE	1	1		
21	90480-12237	GROMMET	1	1		
22	90480-01558	GROMMET	1	1		
23	5GM-24145-00	DAMPER, SIDE COVER	1	1		
24	5GM-24145-10	DAMPER, SIDE COVER	1	1		
25	90464-09008	CLAMP	2	2		
26	5GM-2414H-00	DAMPER, PLATE 1	1	1		
27	2GV-13907-00	FUEL PUMP COMP.	1	1		

**FIG. 21 FUEL TANK**

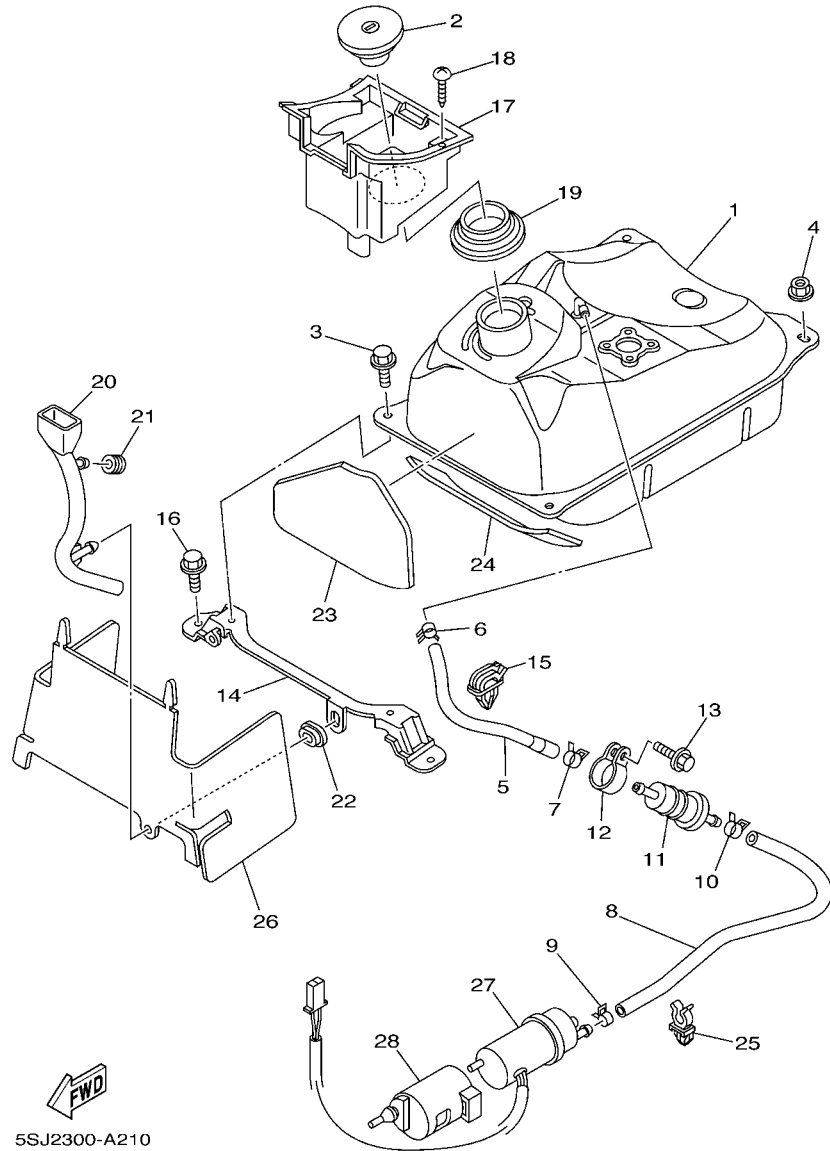

REF. NO.	PART NO.	DESCRIPTION	5S.J9	5S.JB	REMARKS
28	5GM-24492-00	BUSH, FUELE PUMP	1	1	

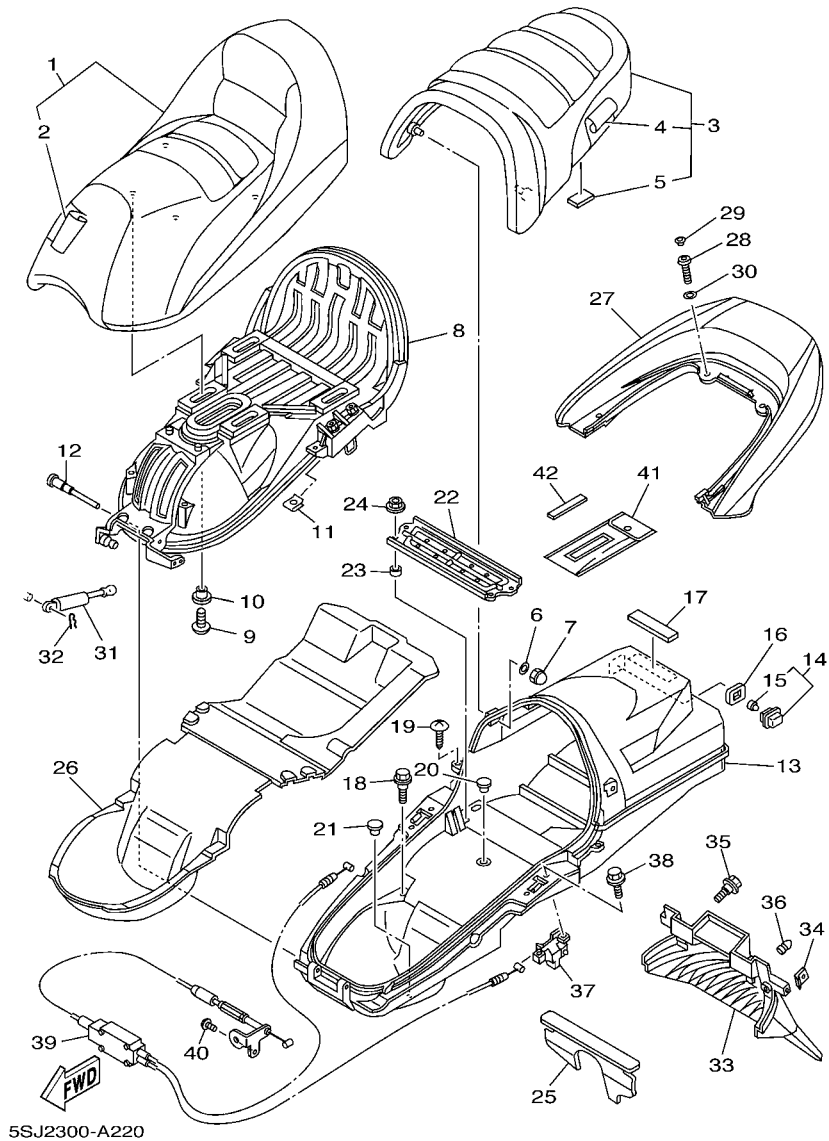

FIG. 22 SEAT

REF. NO.	PART NO.	DESCRIPTION	5S:J9	5S:J8		REMARKS
1	5SJ-24710-20	SINGLE SEAT ASSY	1	1		
2	5SJ-2470F-20	.SEAT COVER COMP.	1	1		
3	5GM-24750-A0	TANDEM SEAT ASSY	1	1		
4	5GM-2470F-B0	.SEAT COVER COMP.	1	1		
5	5GM-24747-00	.DAMPER, SEAT	2	2		
6	90201-06057	WASHER, PLATE	2	2		
7	90176-06003	NUT, CROWN	2	2		
8	5GM-2470E-02	BOTTOM PLATE COMP.	1	1		
9	90110-06202	BOLT, HEXAGON SOCKET HEAD	4	4		
10	90387-06500	COLLAR	4	4		
11	90183-05042	NUT, SPRING	2	2		
12	5GM-24774-00	PIN	1	1		
13	5GM-24704-01	BOX ASSY	1	1		
14	4HC-84770-00	LIGHT, ACCESORY	1	1		
15	4HC-84347-00	.BULB (12V-2W)	1	1		
16	5GM-2839M-00	SEAL, BOX 2	1	1		
17	22F-24182-00	DAMPER, LOCATING 2	1	1		
18	90109-063F1	BOLT	4	4		
19	97707-50016	SCREW, TAPPING	2	2		
20	90338-11125	PLUG	1	1		
21	5GM-2467E-00	CAP	1	1		
22	5GM-24738-00	BRACKET, SEAT	1	1		
23	90560-08326	SPACER	4	4		
24	95707-08500	NUT, FLANGE	4	4		
25	5GM-2177F-00	COVER	1	1		
26	5GM-24723-00	DAMPER, SEAT	1	1		
27	5GM-24773-00-0L	HANDLE, SEAT	1	1		UR MAS

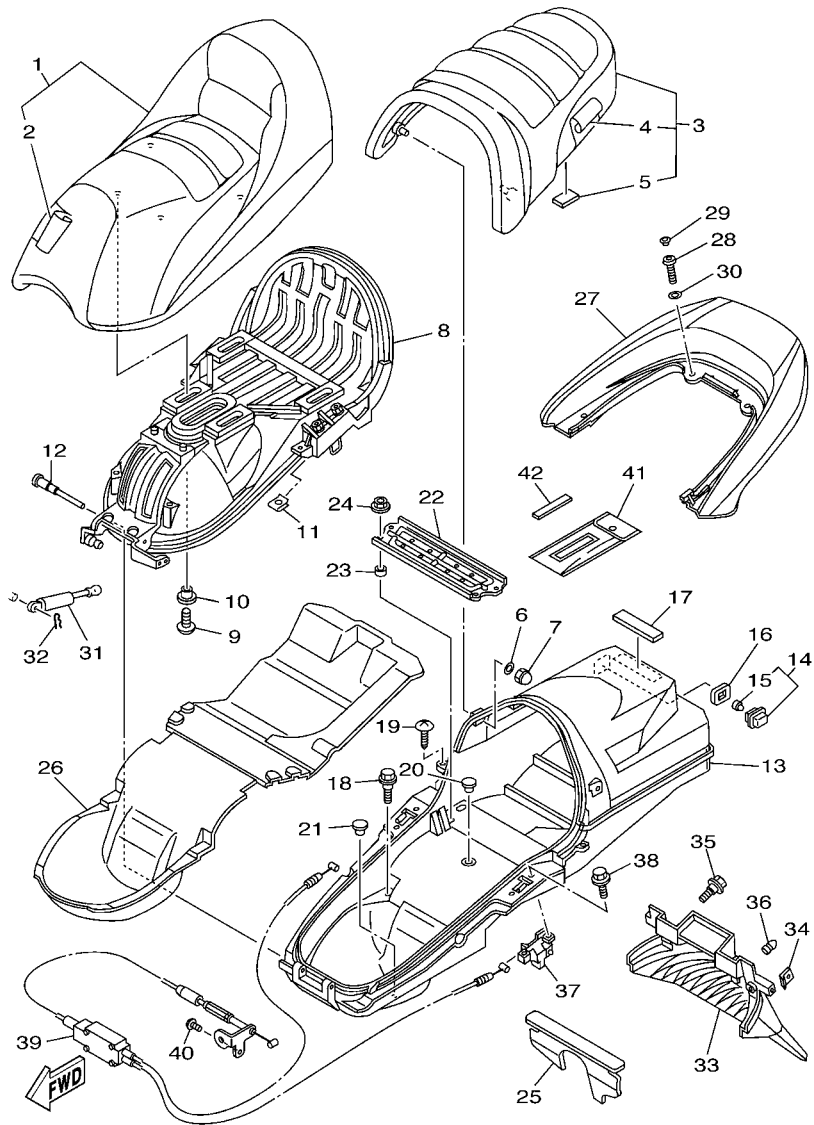
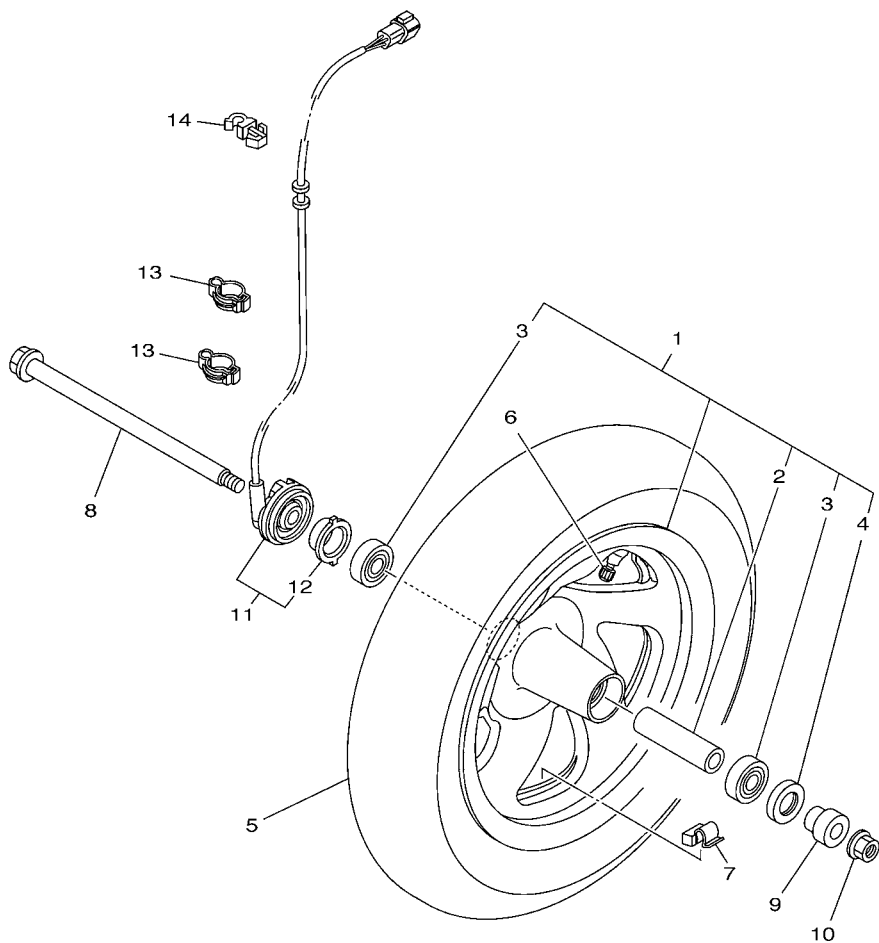

FIG. 22 SEAT

REF. NO.	PART NO.	DESCRIPTION	5S:J9	5S:J8		REMARKS
27	5GM-24773-00-P8	HANDLE, SEAT	1	1		UR DRMD
	5GM-24773-00-PC	HANDLE, SEAT	1	1		UR DNBME
	5GM-24773-00-PD	HANDLE, SEAT	1			UR DNMA
28	90109-084F7	BOLT	4	4		
29	341-23469-00	CAP, BOLT	4	4		
30	90201-08784	WASHER, PLATE	4	4		
31	5GM-2478G-01	STOPPER	1	1		
32	90468-18121	CLIP	1	1		
33	5GM-21629-00	GUARD, MUD	1	1		
34	90183-05042	NUT, SPRING	2	2		
35	90109-063F1	BOLT	2	2		
36	5A8-21639-00	DAMPER 2	1	1		
37	5GM-24780-01	SEAT LOCK ASSY	2	2		
38	90109-063F1	BOLT	4	4		
39	5GM-2478D-01	SEAT LOCK CABLE ASSY	1	1		
40	98507-05010	SCREW, PAN HEAD	1	1		
41	5GM-28100-00	TOOL KIT	1	1		
42	4KG-2814E-10	HOOK	1	1		

**FIG. 23 FRONT WHEEL**

REF. NO.	PART NO.	DESCRIPTION	5SJB	5SJB		REMARKS
1	5RB-25160-00-35	CAST WHEEL, FRONT	1	1		SL
2	5RB-25383-00	.COLLAR, WHEEL	1	1		
3	93306-30212	.BEARING	2	2		
4	93102-22014	.OIL SEAL	1	1		
5	94111-1214N	TIRE (110/90-12 64L MB67/TL)	1	1		UR INOUE
		TIRE (110/90-12 64L TL/TT)	1	1		UR LM MICHELIN
6	93900-00022	VALVE, RIM (TR413)	1	1		TAIHEIYO
7	5MT-25398-00	BALANCER, WHEEL (10G)	1	1		UN
	5MT-25398-10	BALANCER, WHEEL (20G)	1	1		UN
	5MT-25398-20	BALANCER, WHEEL (30G)	1	1		UN
8	4HC-25181-00	AXLE, WHEEL	1	1		
9	90387-151R0	COLLAR	1	1		
10	90185-14166	NUT, SELF-LOCKING	1	1		
11	5RB-83755-01	SENSOR, SPEED	1	1		
12	4YR-2517G-00	.ROTOR, SENSOR		1		
13	90465-14310	CLAMP	2	2		
14	90464-08051	CLAMP	1	1		



5SJ9300-B230

**D6**



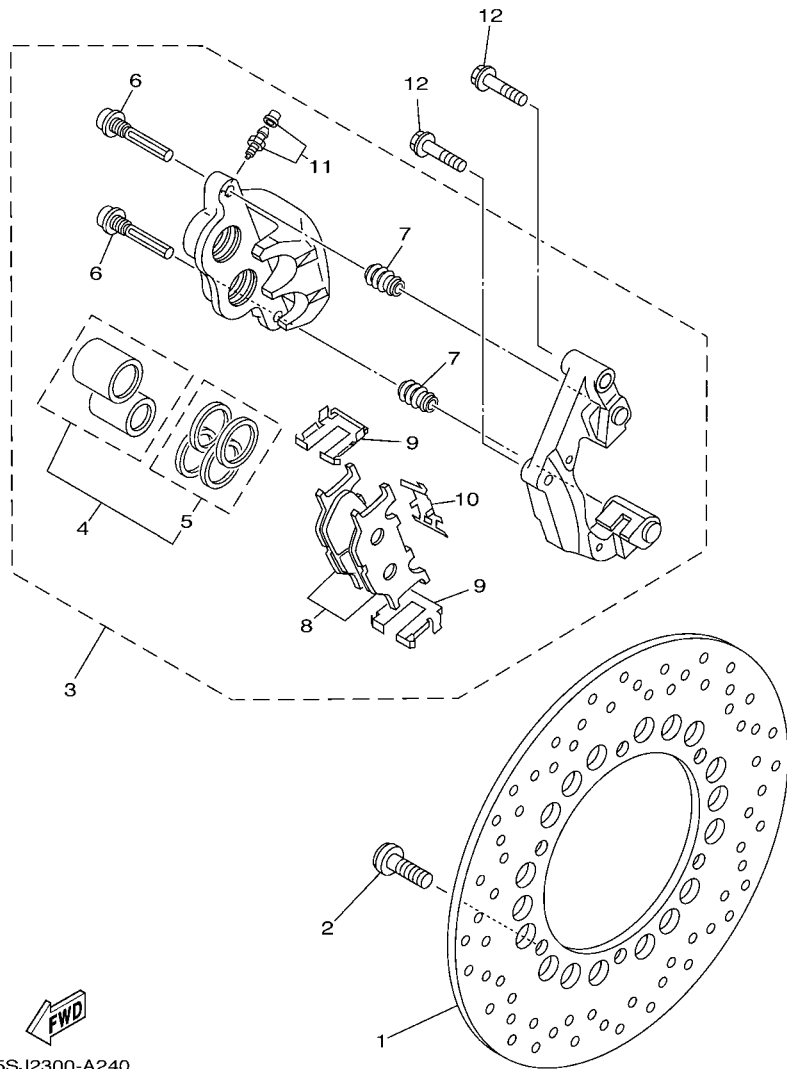

5SJ2300-A240

**FIG. 24 FRONT BRAKE CALIPER**

REF. NO.	PART NO.	DESCRIPTION	SSJ9	SSJ8	REMARKS
1	4HC-2582T-00	DISC, BRAKE (LEFT)	1	1	
2	90109-083G4	BOLT	6	6	
3	5SJ-2580U-00	CALIPER ASSY (RIGHT)	1	1	
4	5KS-W0057-00	.PISTON ASSY, CALIPER	1	1	
5	4FU-W0047-00	..CALIPER SEAL KIT	1	1	
6	5JW-25914-00	.PIN, SLIDE	2	2	
7	4TT-25937-00	.BOOT 2	2	2	
8	4HM-W0045-00	.BRAKE PAD KIT	1	1	
9	4BP-25919-00	.SUPPORT, PAD	2	2	
10	3YX-25929-00	.SPRING, ANTI RATTLE	1	1	
11	51L-W0048-00	.BLEED SCREW KIT	1	1	
12	90105-10638	BOLT, FLANGE	2	2	

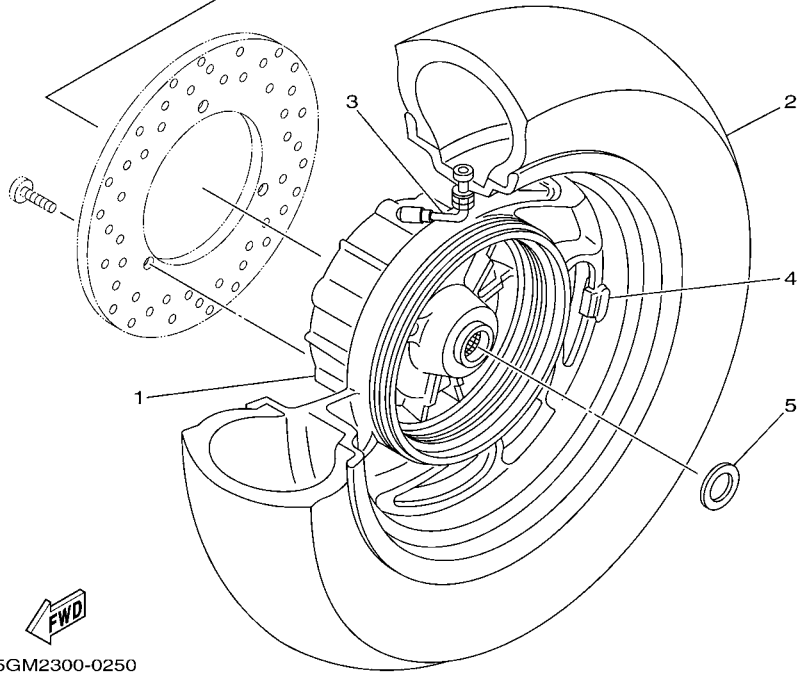
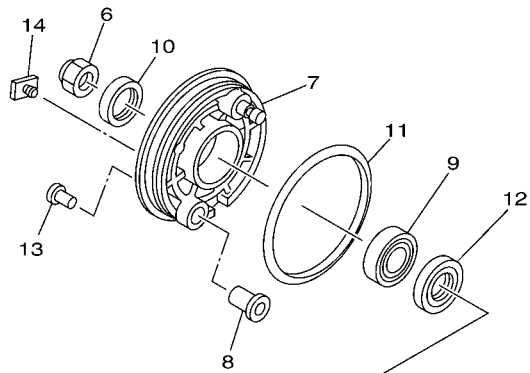

5GM2300-0250

FIG. 25 REAR WHEEL

REF. NO.	PART NO.	DESCRIPTION	SSJ9	SSJ8		REMARKS
1	5GM-25338-00-35	CAST WHEEL, REAR	1	1		SL
2	94113-1204P	TIRE (130/70-12 62L MB67/TL)	1	1		UR INOUE
	*	TIRE (130/70-12 62L TL/TT)	1	1		UR LM MICHELIN
3	93900-00025	VALVE, RIM (TR413)	1	1		
4	5MT-25398-00	BALANCER, WHEEL (10G)	1	1		UN
	5MT-25398-10	BALANCER, WHEEL (20G)	1	1		UN
	5MT-25398-20	BALANCER, WHEEL (30G)	1	1		UN
5	90201-220J8	WASHER, PLATE	1	1		
6	90185-14163	NUT, SELF-LOCKING	1	1		
7	5GM-25321-00-35	PLATE, BRAKE SHOE	1	1		SL
8	5GM-25328-00	BUSH, CAMSHAFT	1	1		
9	93306-30212	BEARING	1	1		
10	93109-28043	OIL SEAL	1	1		
11	5GM-25319-00	SEAL, HUB DUST	1	1		
12	93102-22014	OIL SEAL	1	1		
13	90338-10150	PLUG	1	1		
14	5GM-25683-00	SPACER	1	1		

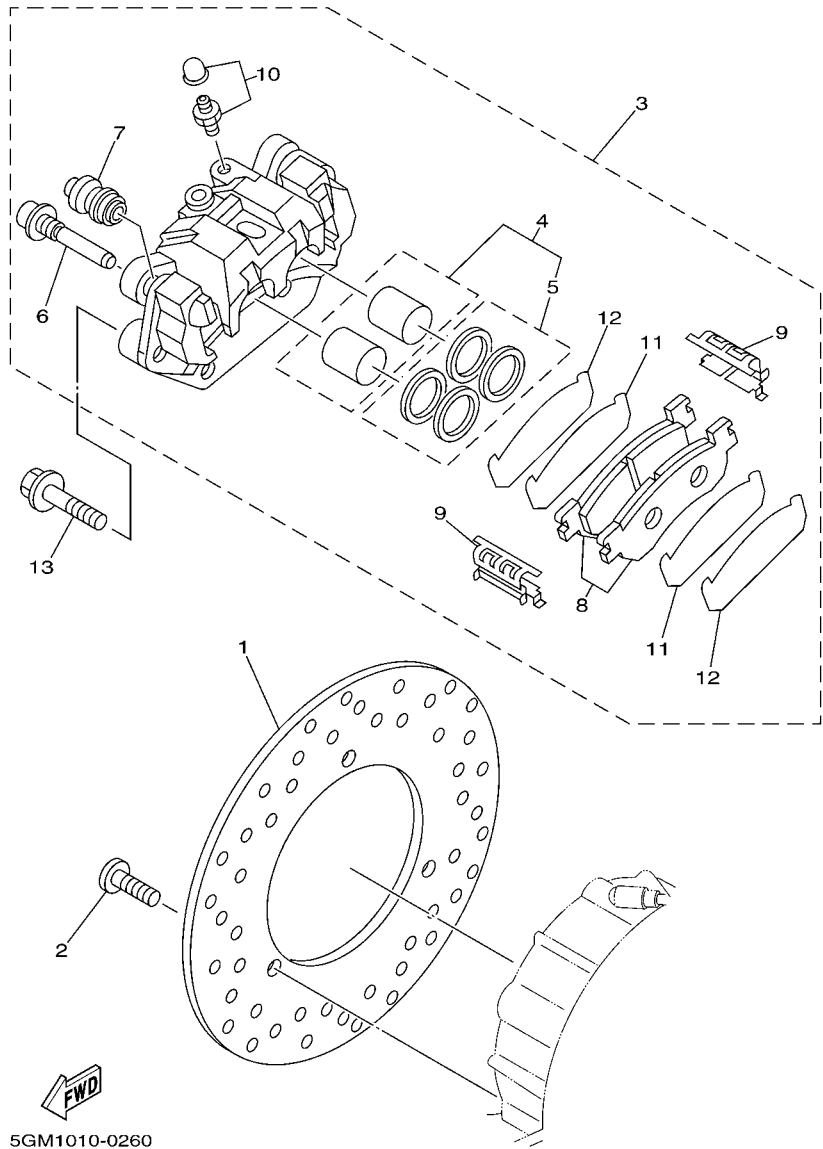

**FIG. 26 REAR BRAKE CALIPER**

REF. NO.	PART NO.	DESCRIPTION	SSJ9	SSJ8			REMARKS
1	5GM-2582W-00	DISC, REAR BRAKE 2	1	1			
2	90109-083G4	BOLT	3	3			
3	5GM-2580W-01	CALIPER ASSY, REAR 2	1	1			
4	5GM-W0057-00	.PISTON ASSY, CALIPER	1	1			
5	4TT-W0047-00	..CALIPER SEAL KIT	1	1			
6	5GM-25914-00	.PIN, SLIDE	2	2			
7	4TT-25937-00	.BOOT 2	2	2			
8	5GM-W0046-00	.BRAKE PAD KIT 2	1	1			
9	4TT-25919-00	.SUPPORT, PAD	2	2			
10	5GM-W0048-00	.BLEED SCREW KIT	1	1			
11	5EB-25828-00	.SHIM, CALIPER	2	2			
12	5GM-25828-00	.SHIM, CALIPER	2	2			
13	90105-10638	BOLT, FLANGE	3	3			

**FIG. 27 STEERING HANDLE. CABLE**

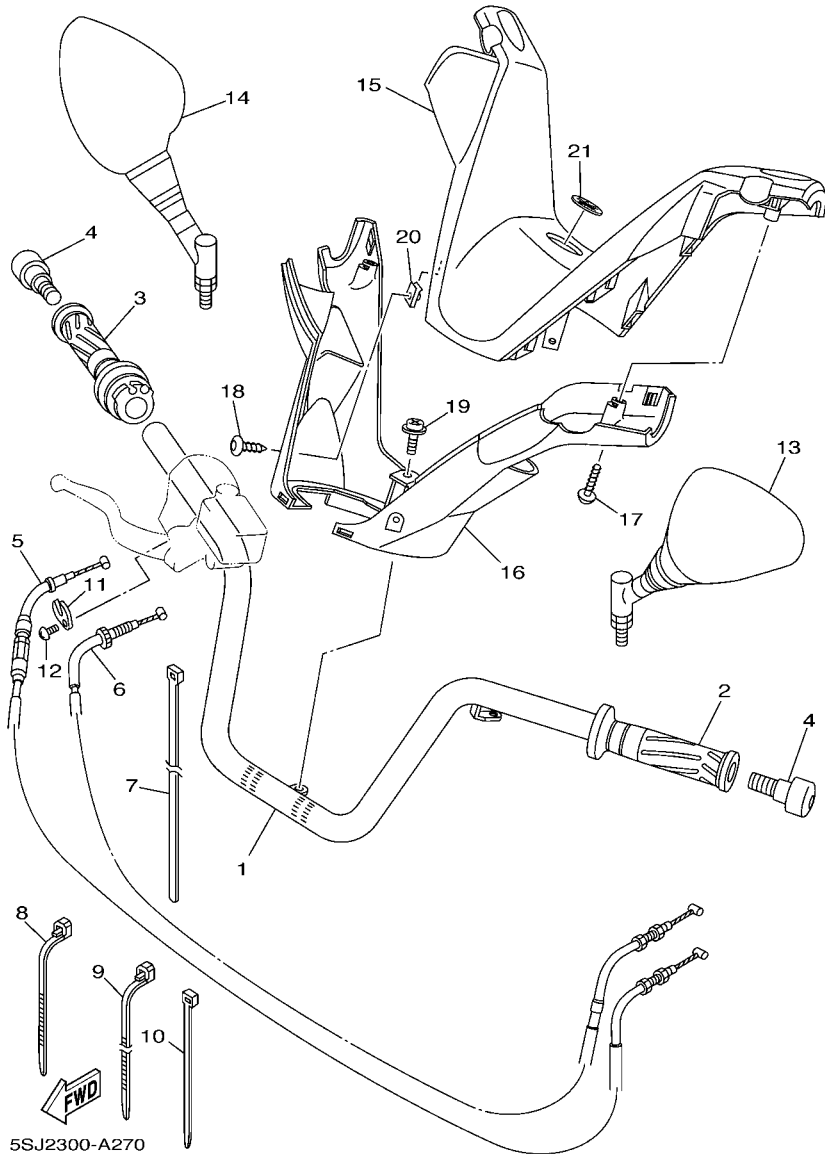

REF. NO.	PART NO.	DESCRIPTION	5S:J9	5S:J8		REMARKS
1	5SJ-26110-00	HANDLE COMP.	1	1		
2	4YR-26241-01	GRIP (LEFT)	1	1		
3	4YR-26240-01	GRIP ASSY	1	1		
4	33M-26246-00	END, GRIP	2	2		
5	5SJ-26311-00	CABLE, THROTTLE 1	1	1		
6	5SJ-26312-00	CABLE, THROTTLE 2	1	1		
7	90464-20258	CLAMP	1	1		
8	90464-15195	CLAMP	2	2		
9	90460-15126	CLAMP, HOSE	1	1		
10	90465-13152	CLAMP	1	1		
11	5H0-26393-00	HOLDER	1	1		
12	98507-05008	SCREW, PAN HEAD	1	1		
13	5CG-26280-01	REAR VIEW MIRROR ASSY (LEFT)	1	1		
14	5CG-26290-01	REAR VIEW MIRROR ASSY (RIGHT)	1	1		
15	5SJ-26143-00	COVER, HANDLEBAR UPPER 1	1	1		
16	5SJ-26144-00	COVER, HANDLEBAR LOWER 1	1	1		
17	90167-05080	SCREW, TAPPING	2	2		
18	90167-05079	SCREW, TAPPING	2	2		
19	90159-05028	SCREW, WITH WASHER	1	1		
20	90183-05042	NUT, SPRING	2	2		
21	5LV-2836B-01	TUNING FORK MARK	1	1		

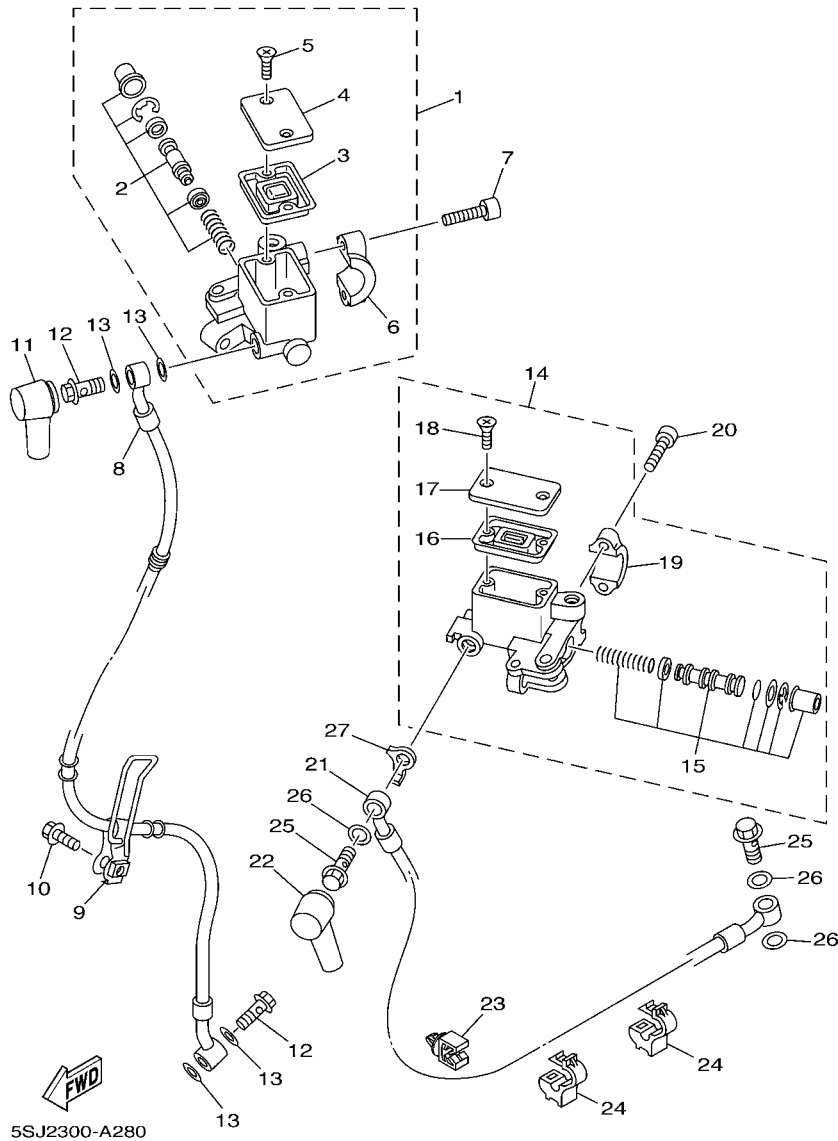

**FIG. 28 FRONT MASTER CYLINDER**

REF. NO.	PART NO.	DESCRIPTION	5S:J9	5S:J8		REMARKS
1	5RB-2583T-00	MASTER CYLINDER ASSY	1	1		
2	1JL-W0041-01	.CYLINDER KIT, MASTER	1	1		
3	3RW-25854-00	.DIAPHRAGM, RESERVOIR	1	1		
4	3RW-25852-00	.CAP, RESERVOIR	1	1		
5	36Y-2589H-00	.SCREW	2	2		
6	3RW-25867-00	.BRACKET, MASTER CYLINDER	1	1		
7	91317-06025	BOLT	2	2		
8	5SJ-25872-10	HOSE, BRAKE 1	1	1		
9	4HC-25876-00	HOLDER, BRAKE HOSE 2	1	1		
10	95807-06020	BOLT, FLANGE	1	1		
11	4L0-25862-01	BOOT, MASTER CYLINDER	1	1		
12	90401-10159	BOLT, UNION	2	2		
13	90201-10118	WASHER, PLATE	4	4		
14	5CG-2583T-A4	MASTER CYLINDER ASSY	1	1		
15	5CG-W0041-10	.CYLINDER KIT, MASTER	1	1		
16	3RW-25854-00	.DIAPHRAGM, RESERVOIR	1	1		
17	4GY-25852-01	.CAP, RESERVOIR	1	1		
18	36Y-2589H-00	.SCREW	2	2		
19	3RW-25867-00	.BRACKET, MASTER CYLINDER	1	1		
20	91317-06025	BOLT	2	2		
21	5SJ-2584A-10	BRAKE HOSE ASSY	1	1		
22	4L0-25862-01	BOOT, MASTER CYLINDER	1	1		
23	5GM-81677-00	CLAMP 1	1	1		
24	90464-05188	CLAMP	2	2		
25	90401-10159	BOLT, UNION	2	2		
26	90201-10118	WASHER, PLATE	3	3		
27	5CG-25844-00	WASHER, LOCK	1	1		

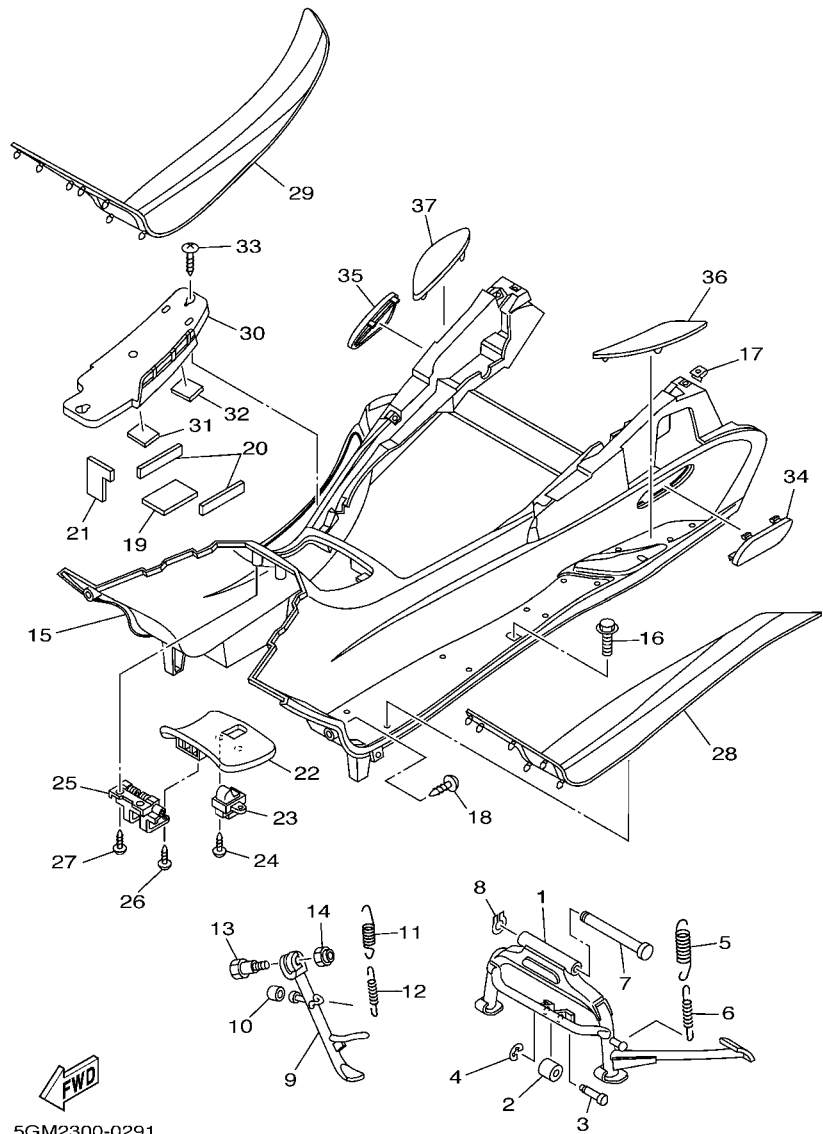

5GM2300-0291

FIG. 29 STAND. FOOTREST

REF. NO.	PART NO.	DESCRIPTION	SSJG	SSJB	REMARKS
1	4HC-27111-01	STAND, MAIN	1	1	
2	4HC-27114-00	STOPPER, MAIN STAND	1	1	
3	4HC-27112-00	SHAFT, MAIN STAND	1	1	
4	99001-04600	CIRCLIP	1	1	
5	90506-40175	SPRING, TENSION	1	1	
6	90506-20158	SPRING, TENSION	1	1	
7	58K-27112-02	SHAFT, MAIN STAND	1	1	
8	93430-12008	CIRCLIP	1	1	
9	5GM-27311-00	STAND, SIDE	1	1	
10	3VR-27114-00	STOPPER, MAIN STAND	1	1	
11	90506-26001	SPRING, TENSION	1	1	
12	90506-18224	SPRING, TENSION	1	1	
13	90109-10473	BOLT	1	1	
14	90185-10110	NUT, SELF-LOCKING	1	1	
15	5GM-27481-01	BOARD, FOOTREST	1	1	
16	90119-06060	BOLT, WITH WASHER	4	4	
17	90183-05042	NUT, SPRING	26	26	
18	97707-50016	SCREW, TAPPING	4	4	
19	5GM-27414-01	DAMPER, FOOTREST	1	1	
20	5GM-27424-00	DAMPER, FOOTREST 2	1	1	
21	5GM-27485-00	SEAL	1	1	
22	5GM-27453-00	COVER 1	1	1	
23	5GM-21780-00	LOCK ASSY	1	1	
24	97707-40512	SCREW, TAPPING	2	2	
25	5GM-2849E-00	HINGE 4	1	1	
26	97707-40010	SCREW, TAPPING	2	2	
27	97707-50016	SCREW, TAPPING	2	2	

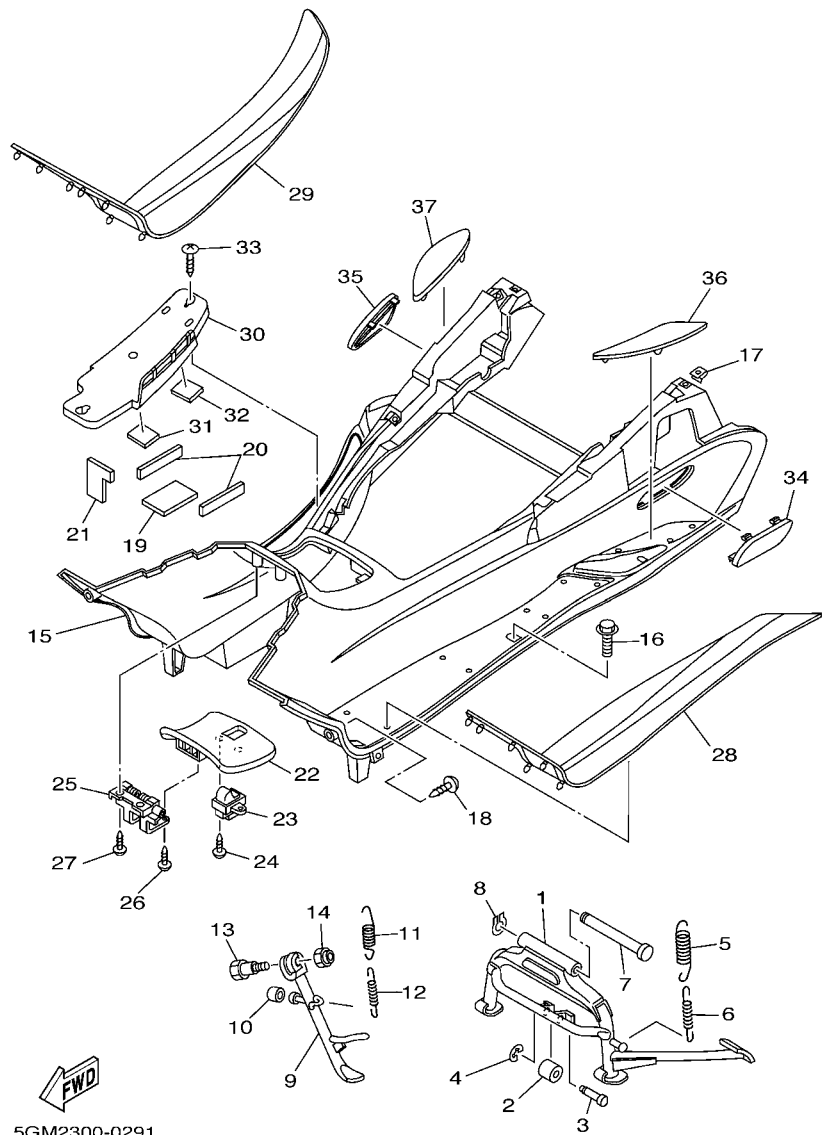

5GM2300-0291

FIG. 29 STAND. FOOTREST

REF. NO.	PART NO.	DESCRIPTION	SS.UG	SS.UB		REMARKS
28	5GM-27483-00	MAT 1	1	1		
29	5GM-27484-00	MAT 2	1	1		
30	5GM-27463-01	COVER 2	1	1		
31	5GM-27482-00	MOLD, FOOTREST	1	1		
32	5GM-27492-00	MOLD, FOOTREST 2	1	1		
33	97707-50012	SCREW, TAPPING	2	2		
34	5GM-27475-00	CAP 1	1	1		
35	5GM-27476-00	CAP 2	1	1		
36	5GM-27486-00	COVER 1	1	1		
37	5GM-27487-00	COVER 2	1	1		
-----						
-----						
-----						
-----						

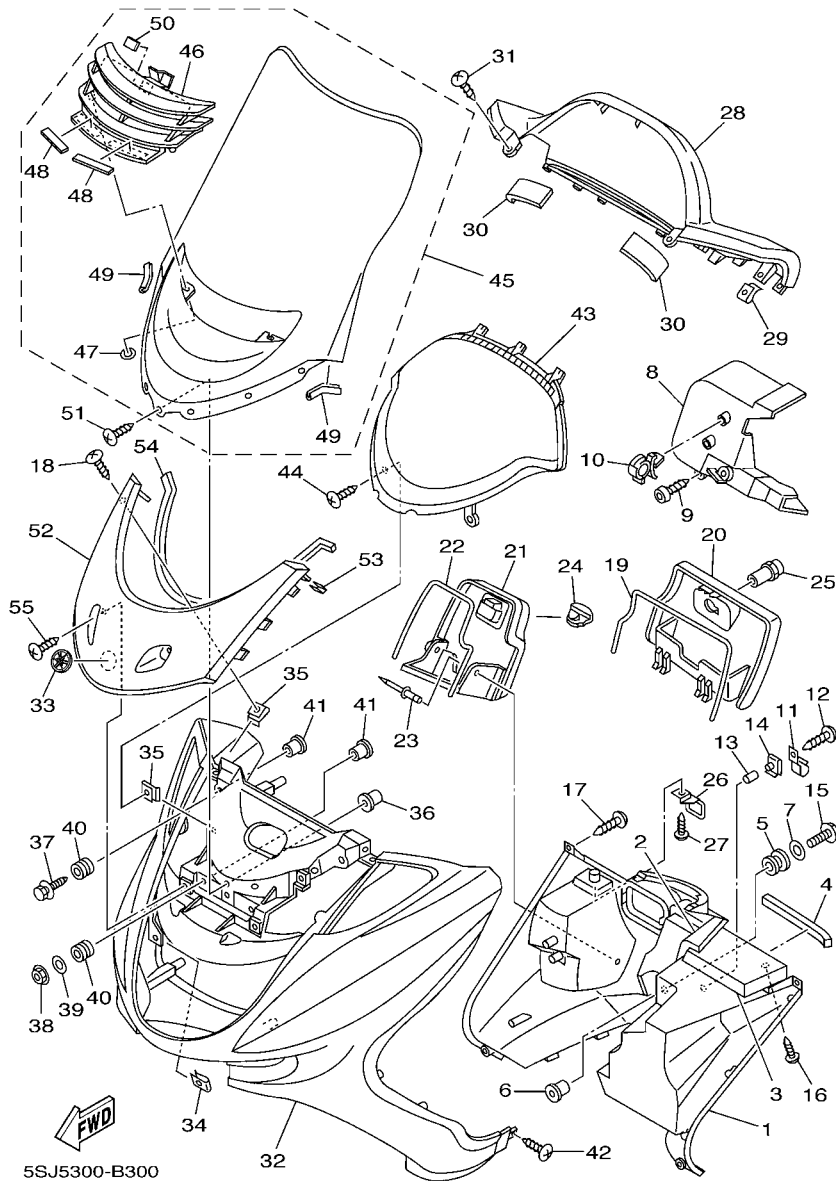

**FIG. 30 LEG SHIELD**

REF. NO.	PART NO.	DESCRIPTION	5SJ9	5SJ8	REMARKS
1	5SJ-28300-00	LEG SHIELD ASSY	1	1	
2	5GM-28415-00	DAMPER 1	1	1	
3	5GM-28416-00	DAMPER 2	1	1	
4	5GM-28435-00	DAMPER 4	1	1	
5	90480-13398	GROMMET	1	1	
6	90387-065J6	COLLAR	1	1	
7	90201-086J0	WASHER, PLATE	1	1	
8	5GM-2835U-02	PANEL 1	1	1	
9	3KJ-24453-00	SCREW	2	2	
10	90464-18246	CLAMP	1	1	
11	4HC-21796-01	HINGE	2	2	
12	97707-40512	SCREW, TAPPING	2	2	
13	90445-057G5	HOSE (L10)	1	1	
14	90183-04027	NUT, SPRING	2	2	
15	90119-06096	BOLT, WITH WASHER	1	1	
16	90167-05079	SCREW, TAPPING	4	4	
17	97707-50016	SCREW, TAPPING	4	4	
18	90167-05079	SCREW, TAPPING	4	4	
19	5GM-28371-00	DAMPER	1	1	
20	5GM-2839K-00	LID 1	1	1	
21	5SJ-2478A-00	LID ASSY	1	1	
22	5SJ-28372-00	DAMPER	1	1	
23	90269-08066	RIVET	1	1	
24	5GM-2837G-00	LOCK 1	1	1	
25	4BH-21780-11	LOCK ASSY	1	1	
26	5GM-2837H-00	LOCK 2	1	1	
27	97707-40512	SCREW, TAPPING	1	1	



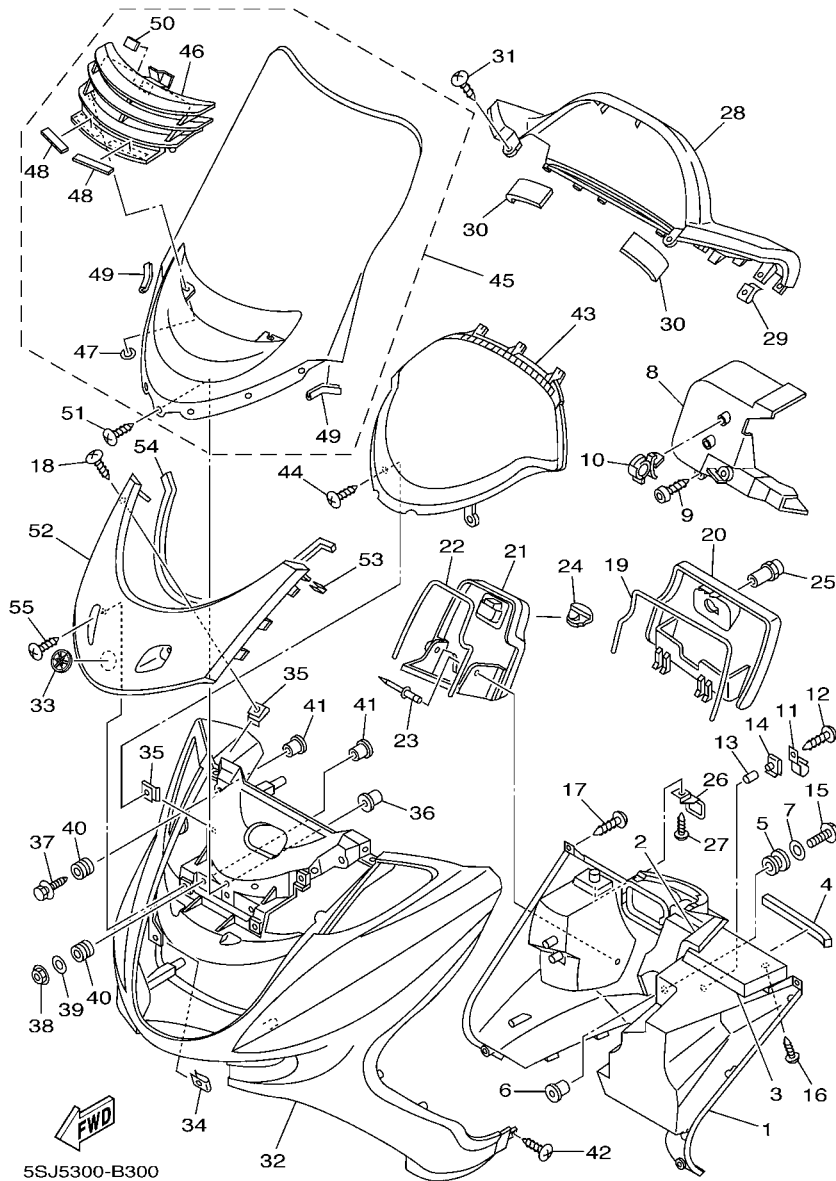

**FIG. 30 LEG SHIELD**

REF. NO.	PART NO.	DESCRIPTION	5SJB	5SJB	REMARKS
28	5SJ-2836K-00	PANEL, INNER 1	1	1	
29	90183-05042	NUT, SPRING	4	4	
30	5GM-2836T-00	DAMPER, LOCATING 1	2	2	
31	97707-50012	SCREW, TAPPING	2	2	
32	5GM-28351-01-0L	BODY, COWLING	1	1	UR MAS
	5GM-28351-01-P8	BODY, COWLING	1	1	UR DRMD
	5GM-28351-01-PC	BODY, COWLING	1	1	UR DNBME
	5GM-28351-01-PD	BODY, COWLING	1	1	UR DNMA
33	5GM-2836B-01	TUNING FORK MARK	1	1	
34	90183-06053	NUT, SPRING	4	4	
35	90183-05042	NUT, SPRING	6	6	
36	90179-05523	NUT	7	7	
37	90119-06163	BOLT, WITH WASHER	2	2	
38	95704-06500	NUT, FLANGE	2	2	
39	90201-06057	WASHER, PLATE	2	2	
40	90480-13398	GROMMET	4	4	
41	90387-067N5	COLLAR	4	4	
42	97707-50012	SCREW, TAPPING	2	2	
43	5GM-2836L-00	PANEL, INNER 2	1	1	
44	97707-50012	SCREW, TAPPING	2	2	
45	5RB-28380-10	WINDSCREEN ASSY	1	1	
46	5GM-2838B-00	.GRILL ASSY	1	1	
47	90183-05004	.NUT, SPRING	2	2	
48	5GM-28344-00	.TAPE	2	2	
49	5GM-2834E-00	.DAMPER 1	2	2	
50	5GM-2834F-00	.DAMPER	1	1	
51	90150-05024	SCREW, ROUND HEAD	7	7	

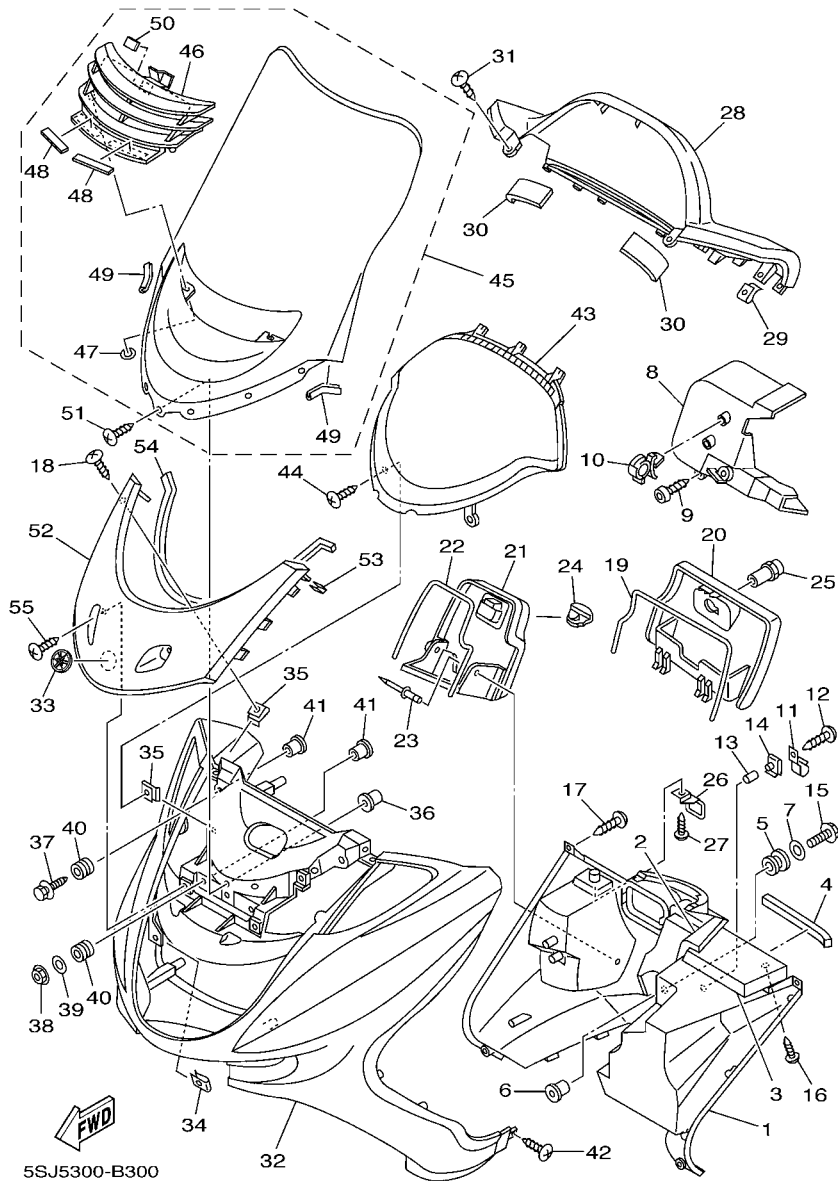
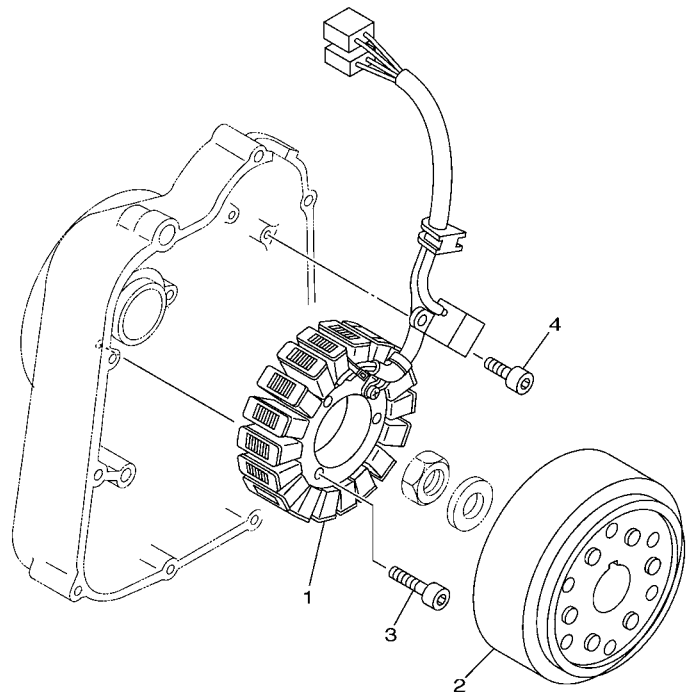

FIG. 30 LEG SHIELD

REF. NO.	PART NO.	DESCRIPTION	5S:J9	5S:J8		REMARKS
52	5GM-28345-01-0L	MOLE 1	1	1		UR MAS
	5GM-28345-01-P8	MOLE 1	1	1		UR DRMD
	5GM-28345-01-PC	MOLE 1	1	1		UR DNBME
	5GM-28345-01-PD	MOLE 1	1			UR DNMA
53	5GM-28379-00	HOOK	2	2		
54	5GM-28347-00	MOLE 3	1	1		
55	90167-05079	SCREW, TAPPING	2	2		

**FIG. 31 GENERATOR**



REF. NO.	PART NO.	DESCRIPTION	SSJ9	SSJ8		REMARKS
1	5GM-81410-00	STATOR ASSY	1	1		
2	5GM-81450-00	ROTOR ASSY	1	1		
3	91317-06030	BOLT	3	3		
4	91317-05012	BOLT	2	2		
-----						
-----						
-----						
-----						
-----						
-----						
-----						
-----						
-----						
-----						

  
5GM1010-0311

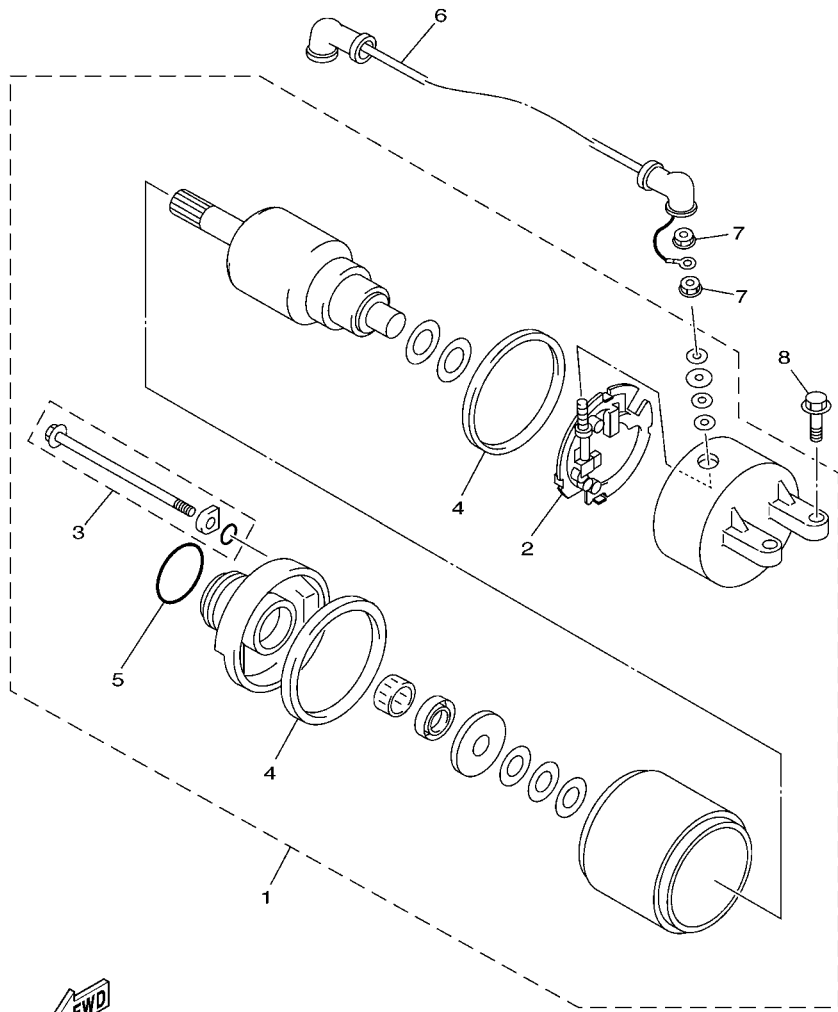

5GM1010-0321

FIG. 32 STARTING MOTOR

REF. NO.	PART NO.	DESCRIPTION	SSJ9	SSJ8	REMARKS
1	4HC-81890-00	MOTOR ASSY	1	1	
2	3KS-81840-00	.BRUSH HOLDER ASSY	1	1	
3	3WP-81826-00	.BOLT	2	2	
4	11H-81844-00	.GASKET	2	2	
5	1FK-81847-00	.O-RING	1	1	
6	5GM-81815-00	CORD, STARTER MOTOR	1	1	
7	4XV-8182A-00	NUT	2	2	
8	95817-06025	BOLT, FLANGE	2	2	

**FIG. 33 FLASHER LIGHT**

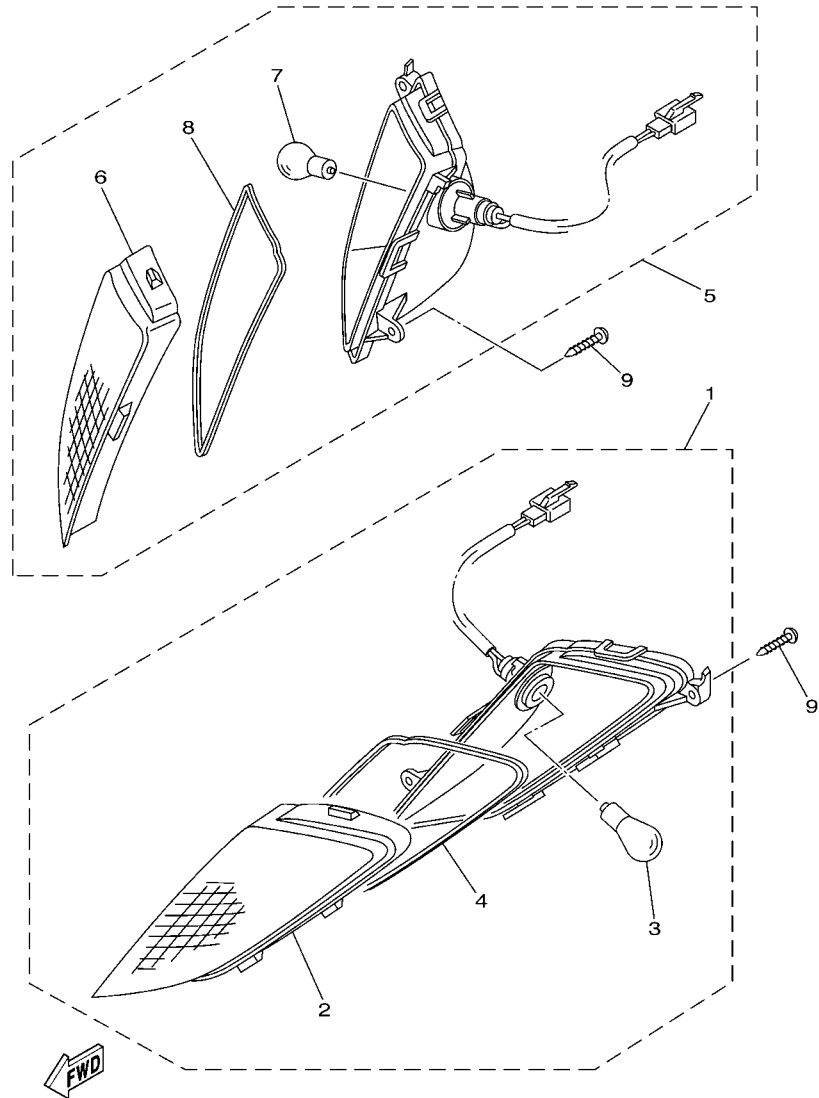

5GM7700-0331

REF. NO.	PART NO.	DESCRIPTION	SSJ9	SSJ8		REMARKS
1	5GM-83310-11	FRONT FLASHER LIGHT ASSY 1	1	1		
2	5GM-83312-00	.LENS, FLASHER	1	1		
3	32H-83331-00	.BULB, FLASHER (12V-21W)	1	1		
4	5GM-83313-00	.GASKET, FLASHER LENS	1	1		
5	5GM-83320-11	FRONT FLASHER LIGHT ASSY 2	1	1		
6	5GM-83322-00	.LENS, FLASHER 2	1	1		
7	32H-83331-00	.BULB, FLASHER (12V-21W)	1	1		
8	5GM-83313-00	.GASKET, FLASHER LENS	1	1		
9	97707-50016	SCREW, TAPPING	4	4		

FIG. 34 METER

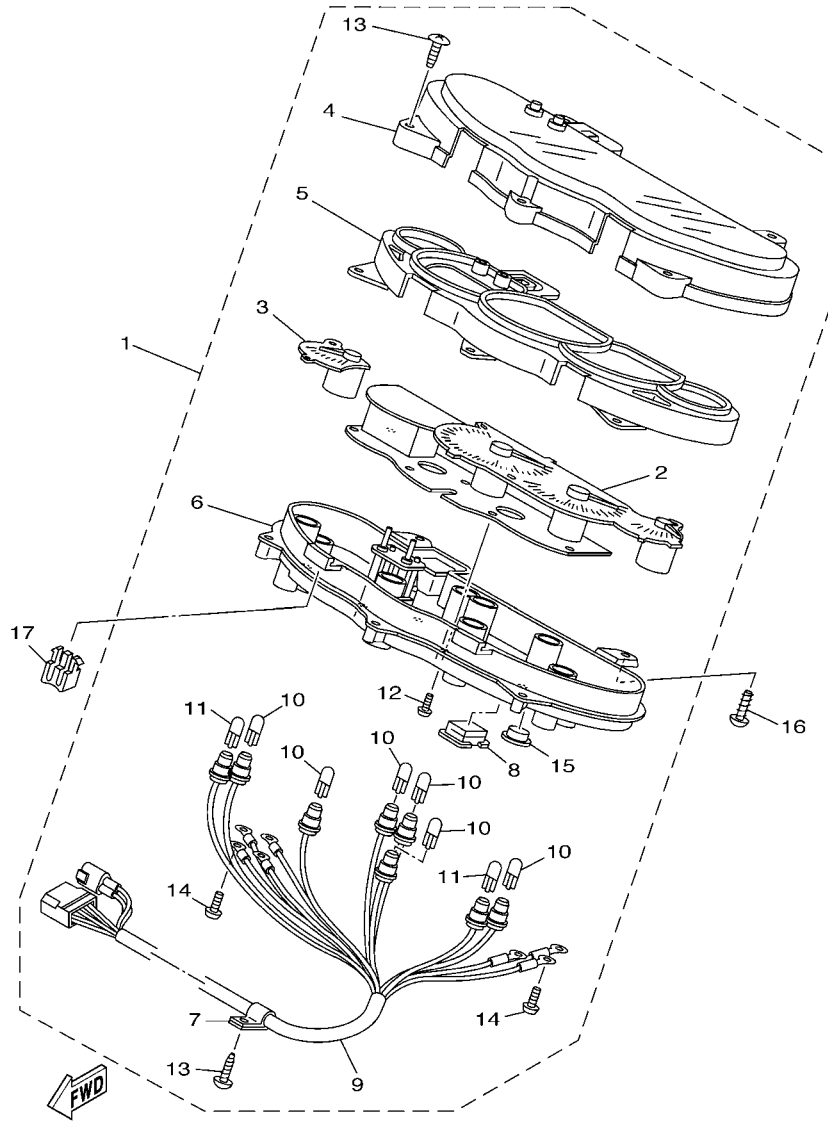

5SJ2300-A340

REF. NO.	PART NO.	DESCRIPTION	5S:J9	5S:J8		REMARKS
1	5SJ-83500-01	SPEEDOMETER ASSY	1	1		UR
	5SJ-83500-51	SPEEDOMETER ASSY	1			UR FOR GBR
2	5SJ-83510-01	.SPEEDOMETER ASSY	1	1		UR
	5SJ-83510-51	.SPEEDOMETER ASSY	1			UR FOR GBR
3	5SJ-8350F-00	.FUEL METER MOVEMENT ASSY	1	1		
4	5SJ-83511-00	.LENS, SPEEDOMETER	1	1		
5	5SJ-83612-00	.COVER, METER PANEL	1	1		
6	5SJ-8353H-00	.CASE, UNDER	1	1		
7	4HC-83595-00	.CLAMP	1	1		
8	5EA-8352K-00	.PLUG, BLIND	1	1		
9	5SJ-83509-00	.SOCKET CORD ASSY	1	1		
10	1YT-83517-00	.BULB (12V-1.7W T10)	6	6		
11	4R0-83517-00	.BULB (12V-3.4W T10)	2	2		
12	97607-30214	.SCREW,WITH WASHER	6	6		
13	97707-40016	.SCREW, TAPPING	5	5		
14	5GM-83616-00	.SCREW, TAPPING	7	7		
15	2GG-8352K-00	.PLUG, BLIND	1	1		
16	97707-50014	SCREW, TAPPING	2	2		
17	4HC-2837G-00	LOCK 1	2	2		

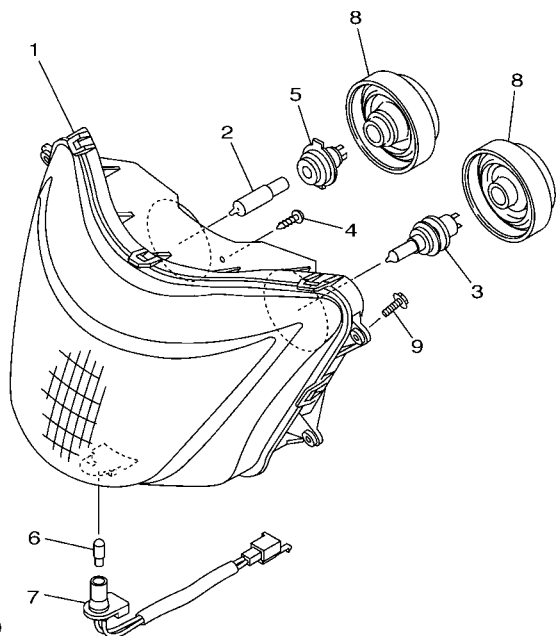
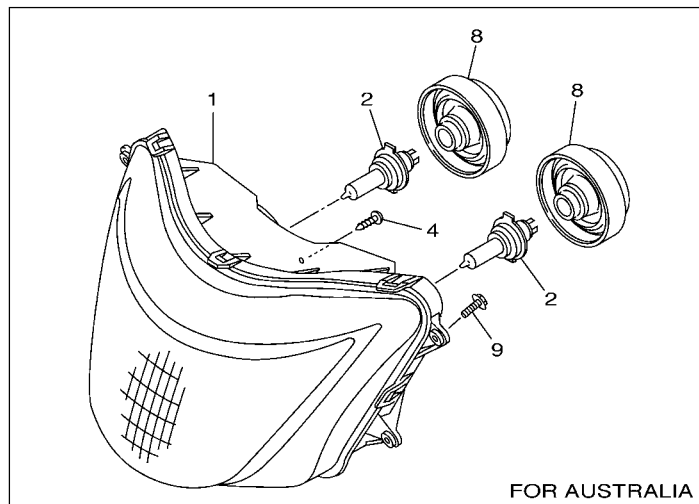

5S.J9300-B350



FIG. 35 HEADLIGHT

REF. NO.	PART NO.	DESCRIPTION	5S.J9	5S.JB	REMARKS
1	5GM-84310-00	HEADLIGHT UNIT ASSY		1	
	5GM-84310-10	HEADLIGHT UNIT ASSY	1		UR
	5GM-84310-20	HEADLIGHT UNIT ASSY	1		UR FOR GBR
2	4SV-84314-00	BULB (12V-55W)	1		(H7)HALOGEN
	4SV-84314-10	BULB (12V-35/35W)		2	
3	8G9-84314-00	BULB (12V-60/55W)	1		(H4)HALOGEN
4	97702-40912	SCREW, TAPPING	5	5	
5	4SV-84350-00	SOCKET CORD ASSY 2	1		
6	4SV-84347-00	BULB (12V-5W)	1		
7	4XV-84312-00	SOCKET CORD ASSY 1	1		
8	5GM-84397-00	COVER, SOCKET	2	2	
9	90119-06052	BOLT, WITH WASHER	4	4	

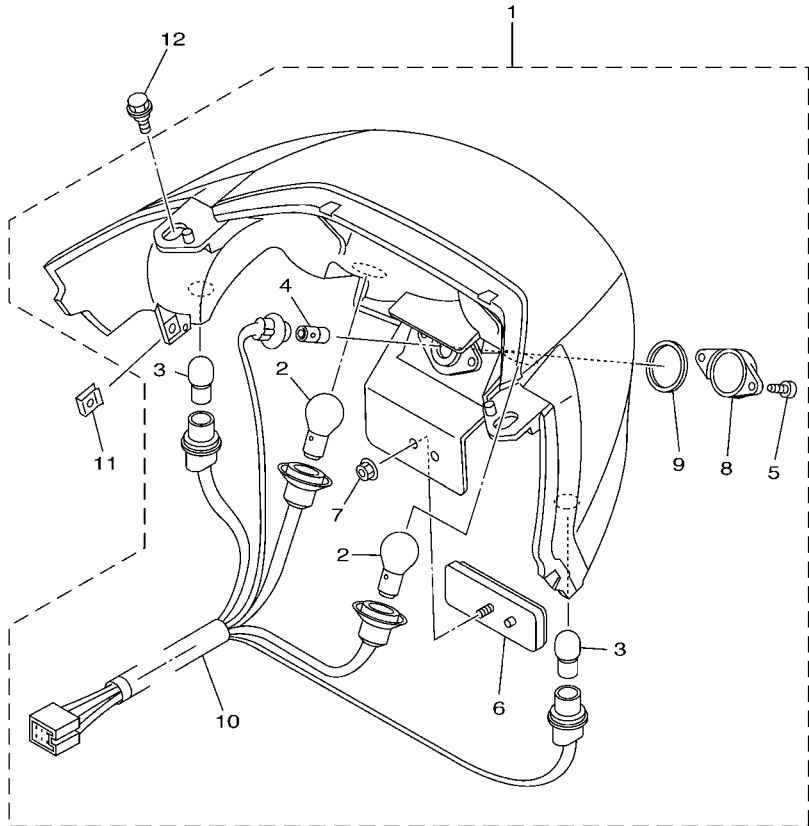

FIG. 36 TAILLIGHT

REF. NO.	PART NO.	DESCRIPTION	5SJB	5SJB		REMARKS
1	5SJ-84710-00	TAILLIGHT UNIT ASSY	1	1		
2	1A2-84714-41	.BULB (12V-21/5W)	2	2		
3	5GM-83311-00	.BULB (12V-18W)	2	2		
4	4HC-84744-00	.BULB (12V-5W)	1	1		
5	97702-40114	.SCREW, TAPPING	2	2		
6	3Y6-85130-02	.REAR REFLECTOR ASSY	1	1		
7	95702-05500	.NUT, FLANGE	1	1		
8	4HC-84743-00	.LENS, LICENCE LIGHT	1	1		
9	4HC-84545-00	.GASKET, LENS	1	1		
10	5SJ-84735-00	.CORD ASSY	1	1		
11	90183-05042	NUT, SPRING	2	2		
12	90109-063F1	BOLT	2	2		



5SJ2300-A360



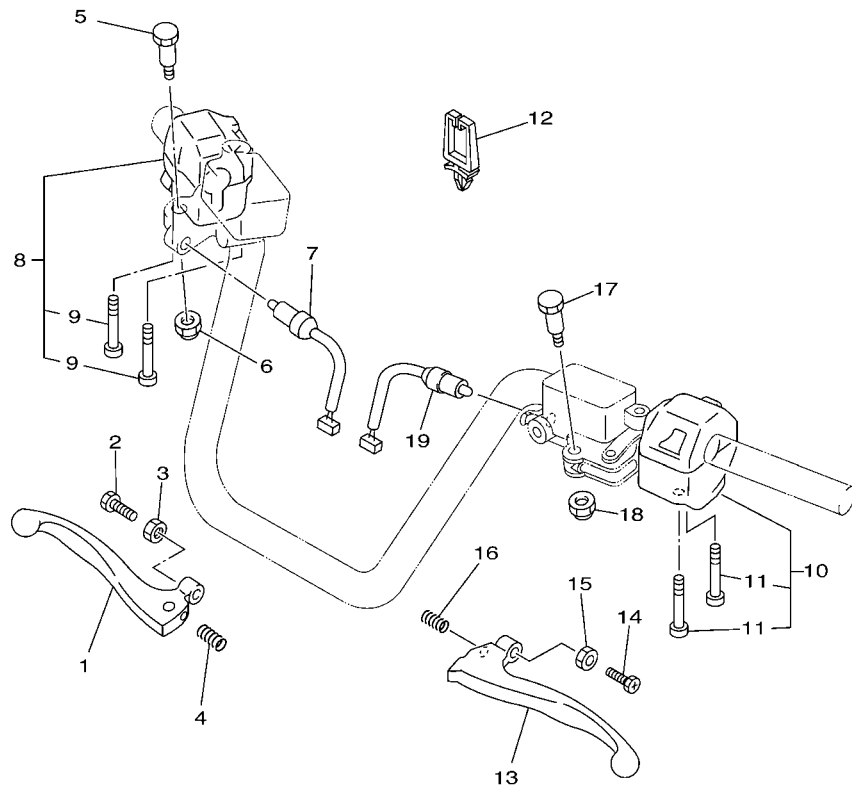

5SJ2300-A370

FIG. 37 HANDLE SWITCH. LEVER

REF. NO.	PART NO.	DESCRIPTION	5SJB	5SJB	REMARKS
1	5CG-83922-01	LEVER 2	1	1	
2	90143-06024	SCREW, HEXAGON	1	1	
3	90170-06010	NUT	1	1	
4	90501-10312	SPRING, COMPRESSION	1	1	
5	90109-06577	BOLT	1	1	
6	95607-06100	NUT, U	1	1	
7	4FU-83980-00	FRONT STOP SWITCH ASSY	1	1	
8	5SJ-83975-00	SWITCH, HANDLE 2	1	1	
9	98507-05045	.SCREW, PAN HEAD	2	2	
10	5SJ-83972-10	SWITCH, HANDLE 4	1	1	
11	98507-05050	.SCREW, PAN HEAD	2	2	
12	90464-05141	CLAMP	1	1	
13	5CG-83912-11	LEVER 1	1	1	
14	90143-06024	SCREW, HEXAGON	1	1	
15	90170-06010	NUT	1	1	
16	90501-10312	SPRING, COMPRESSION	1	1	
17	90109-06577	BOLT	1	1	
18	95607-06100	NUT, U	1	1	
19	4FU-83980-00	FRONT STOP SWITCH ASSY	1	1	

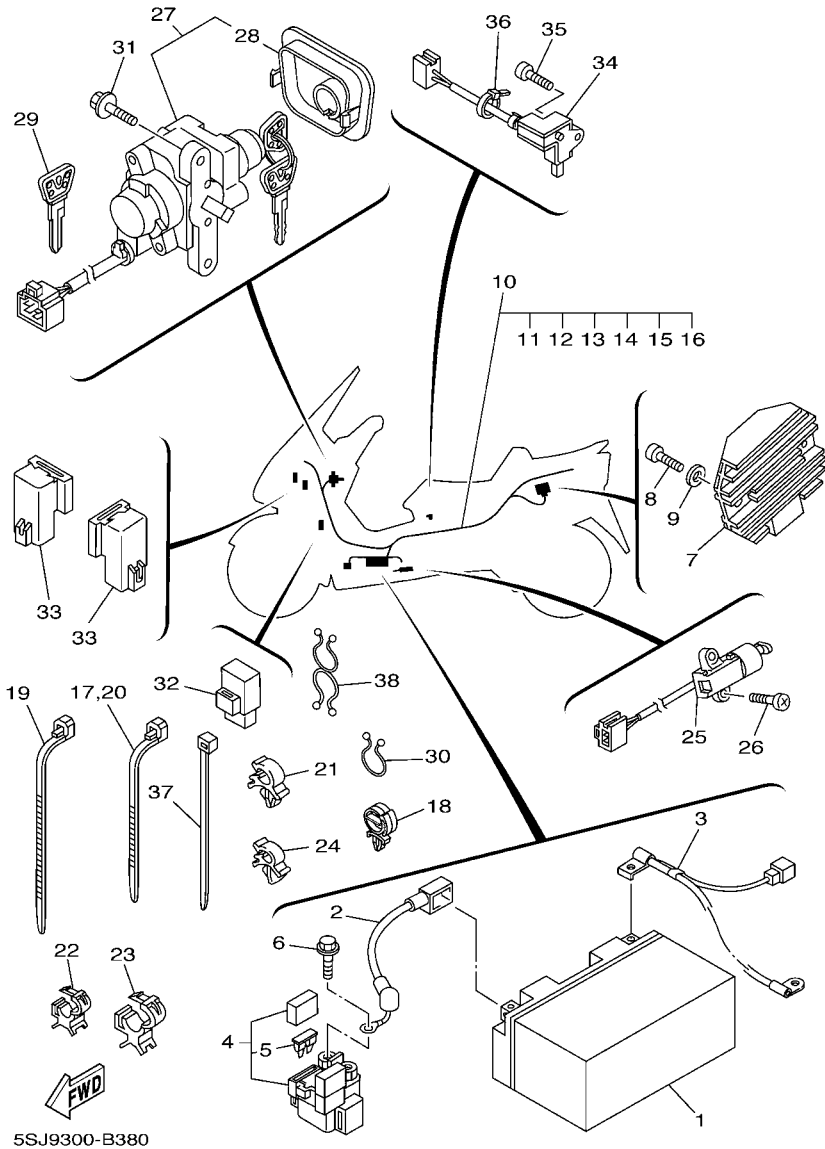

FIG. 38 ELECTRICAL 1

REF. NO.	PART NO.	DESCRIPTION	5S:J9	5S:J8	REMARKS
1	4UC-82100-01	BATTERY (GS GT7B-4)	1	1	
2	5GM-82115-00	WIRE, PLUS LEAD	1	1	
3	5GM-82116-00	WIRE, MINUS LEAD	1	1	
4	4DN-81940-00	STARTER RELAY ASSY	1	1	
5	1AE-82151-00	.FUSE (30A-BL)	2	2	
6	95027-06008	BOLT, FLANGE	2	2	
7	4XY-81960-00	RECTIFIER & REGULATOR ASSY	1	1	
8	98507-06025	SCREW, PAN HEAD	2	2	
9	92907-06600	WASHER, PLATE	2	2	
10	5SJ-82590-10	WIRE HARNESS ASSY	1		
	5SJ-82590-30	WIRE HARNESS ASSY		1	
11	3WP-81980-00	.DIODE ASSY	1		
12	4WA-81980-00	.DIODE ASSY	1	1	
13	5JJ-82151-40	.FUSE (4A-BL)	2	2	
14	5JJ-82151-10	.FUSE (15A-BL)	3	3	
15	5JJ-82151-00	.FUSE (7.5A-BL)	2	2	
16	5JJ-82151-30	.FUSE (10A-BL)	2	2	
17	90464-13073	CLAMP	1	1	
18	90464-20181	CLAMP	1	1	
19	90464-15195	CLAMP	1	1	
20	90464-13073	CLAMP	3	3	
21	90464-11003	CLAMP	5	5	
22	90464-10190	CLAMP	2	2	
23	90464-15192	CLAMP	4	4	
24	90464-07001	CLAMP	3	3	
25	5RT-82566-50	SWITCH, SIDE STAND	1	1	
26	90157-05079	SCREW, PAN HEAD	2	2	

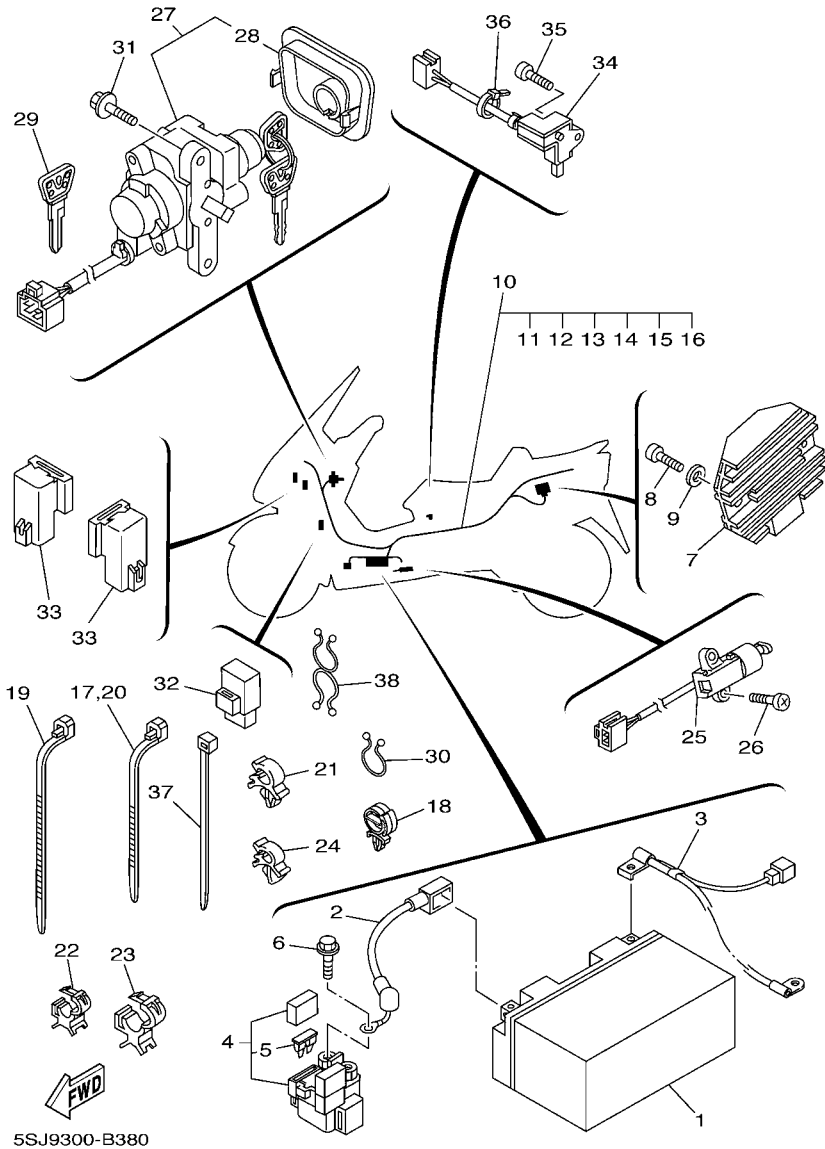

FIG. 38 ELECTRICAL 1

REF. NO.	PART NO.	DESCRIPTION	5S:J9	5S:J8		REMARKS
27	5SJ-82501-10	MAIN SWITCH STEERING LOCK	1			
	5SJ-82501-30	MAIN SWITCH STEERING LOCK		1		
28	5SJ-82552-10	.CAP. SWITCH	1			
	5SJ-82552-20	.CAP. SWITCH		1		
29	4BH-82511-09	BLANK KEY	1	1		AP
30	341-82594-00	CLAMP		1		
31	90109-066A7	BOLT	2	2		
32	4HC-81950-00	RELAY ASSY	1	1		
33	29U-81950-93	RELAY ASSY	2			
	29U-81950-93	RELAY ASSY		1		
34	5GM-81860-00	SWITCH ASSY	1	1		
35	98907-03008	SCREW, BIND	1	1		
36	5Y9-12491-00	CLAMP 1	1	1		
37	5Y9-12491-00	CLAMP 1	2	2		
38	90464-14134	CLAMP	1	1		

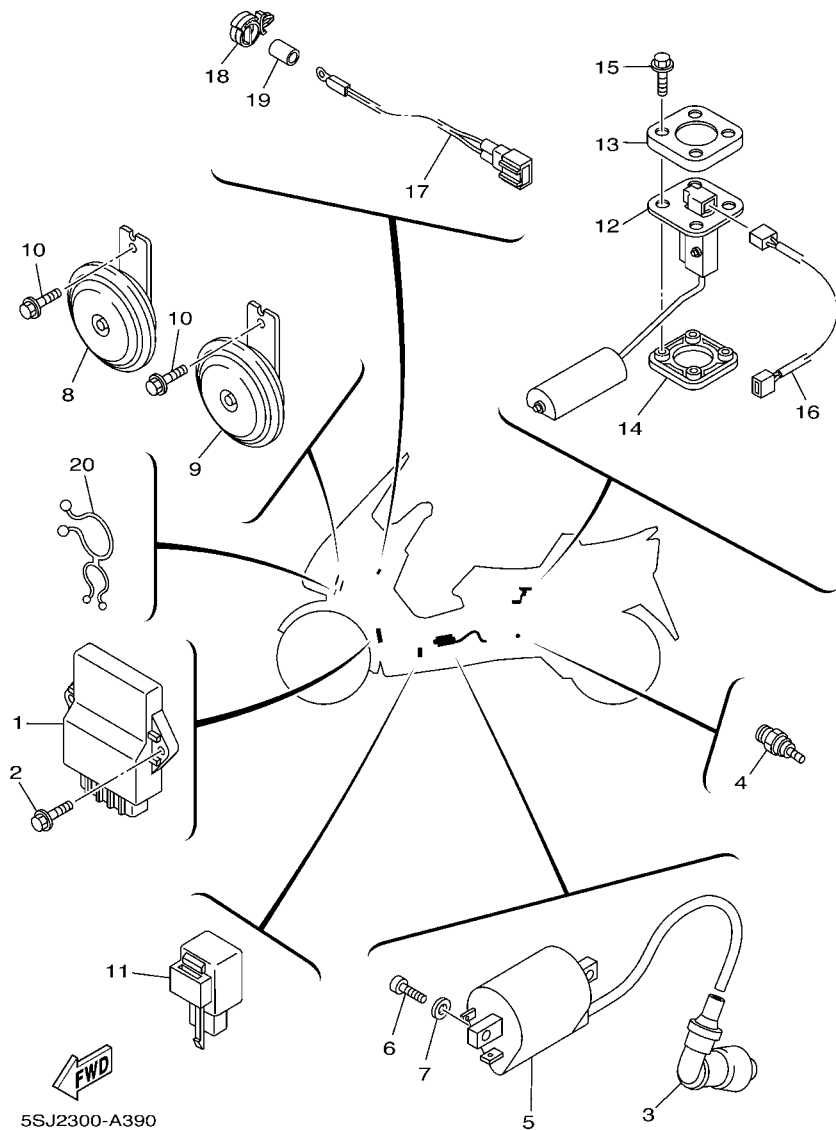

FIG. 39 ELECTRICAL 2

REF. NO.	PART NO.	DESCRIPTION	5S:J9	5S:J8		REMARKS
1	5SJ-82305-10	IGNITOR UNIT ASSY	1	1		
2	95027-06016	BOLT, FLANGE	2	2		
3	4BP-82370-00	PLUG CAP ASSY	1	1		
4	46X-83591-00	THERMO UNIT	1	1		
5	4HC-82310-00	IGNITION COIL ASSY	1	1		
6	98507-05016	SCREW, PAN HEAD	2	2		
7	92907-05600	WASHER, PLATE	2	2		
8	3TB-83371-01	HORN	1	1		
9	5GM-83371-10	HORN	1	1		
10	95807-06010	BOLT, FLANGE	2	2		
11	3GM-83350-01	FLASHER RELAY ASSY	1	1		
12	5GM-85752-00	SENDER UNIT ASSY, FUEL METER	1	1		
13	2JG-85757-00	RETAINER	1	1		
14	4US-85753-00	GASKET, SENDER UNIT	1	1		
15	90119-05071	BOLT, WITH WASHER	4	4		
16	5GM-82509-00	WIRE, SUB LEAD	1	1		
17	JT2-85700-00	THERMISTOR ASSY	1	1		
18	90464-18246	CLAMP	1	1		
19	5SJ-83535-00	TUBE	1	1		
20	90464-25098	CLAMP	1			

NUMERICAL INDEX

PART NO.	GRID NO.	PART NO.	GRID NO.	PART NO.	GRID NO.	PART NO.	GRID NO.	PART NO.	GRID NO.	PART NO.	GRID NO.
5GM-11101-00	B - 2	4HC-12446-00	B - 6	5H0-14397-00	B - 11	4HC-15351-00	B - 9	4HC-21480-00	C - 9	5GM-23110-00	C - 14
4GA-1111F-00	B - 5	5GM-12450-01	B - 6	4KL-14404-00	B - 11	2T4-15363-00	B - 15	4HC-21511-01-OL	C - 10	5RB-23111-00	C - 14
4G0-11133-10	B - 2	4HC-12459-00	B - 6	4HC-14411-00	B - 10	4HC-15363-00	C - 3	4HC-21511-01-PH	C - 10	3J2-23114-00	C - 14
4KB-11145-00	B - 5	5GM-12461-10	B - 7	5GM-14412-01	B - 10	4HC-15378-00	B - 15	4HC-21511-01-PM	C - 10	4HC-23125-20	C - 14
4HC-11160-00	B - 2	4JH-12462-00	B - 7	5GM-1441A-00	B - 10	1UF-15379-00	C - 9	4HC-21511-01-PN	C - 10	4HC-23126-10	C - 14
4HC-11166-00	B - 2	5GM-12476-00	B - 7	4HC-14429-00	B - 11	5GM-15407-00	C - 3	5GM-21552-00	C - 10	4HC-23136-11	C - 14
4HC-11181-01	B - 2	5GM-12481-00	B - 7	5GM-14437-00	B - 10	5GM-15411-00	C - 3	5GM-21629-00	D - 5	5GM-23141-00	C - 14
3GC-11186-00	B - 2	5GM-12482-00	B - 7	4HC-14451-00	B - 10	4HC-14451-00	C - 3	5A8-21639-00	D - 5	2UJ-23144-00	C - 14
3GC-11187-00	B - 2	5GM-12483-00	B - 7	4HC-14452-00	B - 10	5GM-15421-00	B - 15	5GM-21711-01-OL	C - 11	2UJ-23145-00	C - 14
4HC-11311-00	B - 2	5GM-12484-00	B - 7	4HC-14453-01	B - 10	5GM-15431-00	C - 3	5GM-21711-01-P8	C - 11	22W-23146-L0	C - 14
4HC-11351-00	B - 2	5GM-12485-00	B - 7	17W-14462-00	C - 3	5GM-15451-00	C - 3	5GM-21711-01-PC	C - 11	3DM-23149-10	C - 14
5GM-11400-10	B - 3	5Y9-12491-00	E - 11	4HC-14472-00	B - 10	4HC-15453-00	C - 3	5GM-21711-01-PD	C - 11	22W-23153-L0	C - 14
4HC-11603-00	B - 3	4HC-12576-00	B - 7	4KL-14536-00	B - 11	4HC-15461-00	B - 15	5GM-2171L-00-OL	C - 11	509-23158-L0	C - 14
4HC-11605-00	B - 3	4HC-12577-00	B - 7	5GM-14565-00	B - 12	5GM-15471-00	C - 3	5GM-2171L-00-P8	C - 11	5GM-23170-00	C - 14
4HC-11607-00	B - 3	4HC-12591-00	B - 7	4HC-14592-00	B - 11	4HC-15472-00	C - 3	5GM-2171L-00-PC	C - 11	5SJ-23170-00	C - 14
4HC-11631-01	B - 3	4HC-13300-00	B - 9	5GM-14611-10	B - 13	3KJ-15481-00	C - 3	5GM-2171M-00-PD	C - 11	4HC-23173-20	C - 14
4JH-11633-00	B - 3	4HC-13325-00	B - 9	3MT-14613-00	B - 13	5GM-15491-00	C - 3	5GM-2171M-00-OL	C - 11	278-23181-50	C - 14
4HC-11636-01	B - 3	51Y-13411-00	B - 9	4HC-14628-00	B - 13	4HC-15492-00	B - 15	5GM-2171M-00-P8	C - 11	3G2-23183-00	C - 14
4HC-11638-01	B - 3	4HC-13475-00	B - 9	5RB-14711-00	B - 13	5GM-15499-00	C - 3	5GM-2171M-00-PC	C - 12	4HC-23184-10	C - 14
5GM-12111-00	B - 4	5GM-13542-00	B - 14	4BH-14714-00	B - 13	4HC-15512-00	C - 5	5GM-2171M-00-PD	C - 12	5RB-23317-00	C - 15
4HC-12113-00	B - 4	4HC-13586-11	B - 10	5SJ-14718-00	B - 13	4HC-15517-00	C - 5	5GM-2171N-00-OL	C - 12	5GM-23340-01	C - 14
4HC-12114-00	B - 4	4HC-13595-00	B - 10	5GM-14728-00	B - 13	2HT-15521-00	C - 5	5GM-2171N-00-P8	C - 12	22F-23411-01	C - 14
4G0-12116-01	B - 4	2GV-13907-00	D - 2	5GM-14738-00	B - 13	4HC-15590-00	C - 5	5GM-2171N-00-PC	C - 12	22F-23412-01	C - 15
4G0-12117-00	B - 4	4HC-14103-00	B - 11	5RB-14748-00	B - 13	5GM-16111-00	C - 8	5GM-2171N-00-PD	C - 12	3VP-23416-00	C - 15
4G0-12118-00	B - 4	5GM-14105-00	B - 11	5RB-14758-00	B - 13	5GM-16151-00	C - 8	5GM-21721-01-OL	C - 11	3YF-23418-00	C - 15
5H0-12119-00	B - 4	5GM-1410A-10	B - 11	4BD-14766-00	B - 13	5GM-16611-00	C - 6	5GM-21721-01-P8	C - 11	22F-2341E-00	C - 14
5H0-12121-01	B - 4	4KL-14115-00	B - 11	5RB-14766-00	B - 13	5GM-16620-00	C - 6	5GM-21721-01-PC	C - 11	4H7-23441-10	C - 15
5H0-12146-00	B - 4	4HC-14147-00	B - 11	5SJ-14799-00	B - 13	5KD-16626-10	C - 6	5GM-21721-01-PD	C - 11	5SJ-23442-00	C - 15
36X-12151-00	B - 4	4HC-14196-00	B - 12	5GM-14803-00	B - 14	5GM-17211-00	C - 8	5GM-21731-00	C - 12	164-23462-00	C - 14
3Y1-12156-00	B - 4	4HC-14197-00	B - 12	5GM-14806-00	B - 14	5GM-17411-00	C - 8	5GM-2173B-00	C - 12	341-23469-00	D - 5
4HC-12157-00	B - 5	5GM-14197-00	B - 12	5GM-14815-00	B - 13	5GM-17421-00	C - 8	5GM-21778-00	C - 11	5GM-24110-11	D - 2
2NX-12159-00	B - 4	5GM-14243-00	B - 12	5GM-1482K-00	B - 13	4HC-17611-00	C - 6	5GM-21779-00	C - 11	3HA-24141-00	C - 9
4HC-12170-00	B - 5	4JP-14243-01	B - 11	5GM-14871-01	B - 13	5GM-17620-00	C - 6	5GM-2177F-00	D - 4	5GM-24145-00	D - 2
4HC-12176-00	B - 5	4KL-14272-01	B - 11	5GM-14881-00	B - 13	4HC-17623-00	C - 6	5GM-21780-00	D - 12	5GM-24145-10	D - 2
2UJ-12210-01	B - 5	4HC-14286-00	B - 12	5GM-14882-00	B - 14	4CW-17632-01	C - 6	4BH-21780-11	D - 14	5GM-2414A-00	D - 2
4RF-12213-00	B - 5	5GM-14294-00	B - 10	5GM-14883-00	B - 14	5CG-17639-00	C - 6	4HC-21796-01	D - 14	5GM-2414G-00	D - 2
4HC-12231-00	B - 5	5GM-14301-11	B - 11	4HC-1490A-00	B - 11	5CG-17641-00	C - 6	1AA-21815-00	C - 12	5GM-2414H-00	D - 2
4HC-12241-00	B - 5	4HC-14340-01	B - 11	4HC-1490H-08	B - 11	5GM-17644-00	C - 6	5GM-21816-00	C - 12	22F-24182-00	D - 4
5GM-12405-00	B - 7	4UC-14341-00	B - 12	5GM-1490J-00	B - 11	5GM-17649-00	C - 2	5GM-21817-00	C - 12	5GM-24191-00	D - 2
4HC-12411-00	B - 7	4UC-14341-10	B - 12	4HC-14958-00	B - 11	4HC-17653-00	C - 6	5GM-21871-00	C - 12	5GM-24311-00	D - 2
4HC-12413-00	B - 7	38V-14342-71	B - 12	5GM-15100-00	B - 15	4HC-17654-00	C - 6	1AA-21874-00	C - 12	5GM-24312-00	D - 2
5GM-12420-01	B - 6	50M-14343-64	B - 12	36Y-15189-00	C - 4	5GM-17660-00	C - 6	5GM-22100-00	C - 13	1AE-24366-00	D - 2
4HC-12421-00	B - 6	50M-14355-00	B - 12	5GM-15199-00	B - 15	4CW-17664-00	C - 6	5GM-22210-00	C - 13	3KJ-24453-00	D - 14
4HC-12422-01	B - 6	4KL-14384-00	B - 11	5GM-15316-00	C - 3	4HC-17670-10	C - 6	5SJ-22210-00	C - 13	5GM-24492-00	D - 3
5GM-12426-00	B - 6	25N-14385-00	B - 11	5GM-15326-00	C - 3	5GM-21110-02	C - 9	164-22216-00	B - 15	214-24535-00	B - 11
4HC-12428-10	B - 6	4KL-14386-00	B - 11	5GM-15335-00	C - 3	5CG-21279-00	C - 10		C - 13	1FK-24560-10	D - 2
11H-12438-10	B - 6	4HC-14390-00	B - 11	5GM-15337-00	C - 3	5GM-21417-00	C - 9	5SJ-23100-00	C - 14	3KJ-24602-03	D - 2
5GM-12443-00	B - 7	4KL-14397-00	B - 11	5GM-15338-00	C - 3	5CG-21420-01	C - 9	5GM-23100-01	C - 14	5GM-24667-00	D - 2

NUMERICAL INDEX

PART NO.	GRID NO.	PART NO.	GRID NO.	PART NO.	GRID NO.	PART NO.	GRID NO.	PART NO.	GRID NO.	PART NO.	GRID NO.
5GM-2467E-00	D - 4	3RW-25867-00	D - 11	5GM-27486-00	D - 13	1FK-81847-00	E - 4	5SJ-83511-00	E - 6	5GM-W0048-00	D - 9
5GM-24704-01	D - 4	5SJ-25872-10	D - 11	5GM-27487-00	D - 13	5GM-81860-00	E - 11	1YT-83517-00	E - 6	5GM-W0057-00	D - 9
5GM-2470E-02	D - 4	5GM-25875-00	C - 13	5GM-27492-00	D - 13	4HC-81890-00	E - 4	4R0-83517-00	E - 6	5KS-W0057-00	D - 7
5SJ-2470F-20	D - 4	4HC-25875-01	C - 15	5GM-28100-00	D - 5	4DN-81940-00	E - 10	2GG-8352K-00	E - 6	90101-10303	B - 5
5GM-2470F-B0	D - 4	4HC-25876-00	D - 11	4KG-2814E-10	D - 5	4HC-81950-00	E - 11	5EA-8352K-00	E - 6	90105-05002	C - 15
5SJ-24710-20	D - 4	5SJ-25887-00	C - 15	5SJ-28300-00	D - 14	29U-81950-93	E - 11	5SJ-83535-00	E - 12	90105-10023	C - 9
5GM-24723-00	D - 4	36Y-2589H-00	D - 11	5GM-28344-00	D - 15	4XY-81960-00	E - 10	5SJ-8353H-00	E - 6	90105-10638	D - 7
5GM-24738-00	D - 4	5GM-25914-00	D - 9	5GM-28345-01-0L	E - 2	3WP-81980-00	E - 10	46X-83591-00	E - 12		D - 9
5GM-24747-00	D - 4	5JW-25914-00	D - 7	5GM-28345-01-P8	E - 2	4WA-81980-00	E - 10	4HC-83595-00	E - 6	90109-06030	C - 3
5GM-24750-A0	D - 4	4BP-25919-00	D - 7	5GM-28345-01-PC	E - 2	4UC-82100-01	E - 10	5SJ-83612-00	E - 6	90109-060F3	C - 10
5GM-24773-00-0L	D - 4	4TT-25919-00	D - 9	5GM-28345-01-PD	E - 2	5GM-82115-00	E - 10	5GM-83616-00	E - 6	90109-063F1	C - 12
5GM-24773-00-P8	D - 5	3YX-25929-00	D - 7	5GM-28347-00	E - 2	5GM-82116-00	E - 10	5RB-83755-01	D - 6		D - 4
5GM-24773-00-PC	D - 5	4TT-25937-00	D - 7	5GM-2834E-00	D - 15	1AE-82151-00	E - 10	5CG-83912-11	E - 9		E - 8
5GM-24773-00-PD	D - 5		D - 9	5GM-2834F-00	D - 15	5JJ-82151-00	E - 10	5CG-83922-01	E - 9	90109-06577	E - 9
5GM-24774-00	D - 4	5SJ-26110-00	D - 10	5GM-28351-01-0L	D - 15	5JJ-82151-10	E - 10	5SJ-83972-10	E - 9	90109-066A7	E - 11
5GM-24780-01	D - 5	5SJ-26143-00	D - 10	5GM-28351-01-P8	D - 15	5JJ-82151-30	E - 10	5SJ-83975-00	E - 9	90109-067E6	B - 10
5SJ-2478A-00	D - 14	5SJ-26144-00	D - 10	5GM-28351-01-PC	D - 15	5JJ-82151-40	E - 10	4FU-83980-00	E - 9	90109-082F5	B - 15
5GM-2478D-01	D - 5	4YR-26240-01	D - 10	5GM-28351-01-PD	D - 15	5SJ-82305-10	E - 12	5GM-84310-00	E - 7	90109-083G4	D - 7
5GM-2478G-01	D - 5	4YR-26241-01	D - 10	5SJ-28356-10	C - 9	4HC-82310-00	E - 12	5GM-84310-10	E - 7		D - 9
5RB-25160-00-35	D - 6	33M-26246-00	D - 10	5GM-2835U-02	D - 14	4BP-82370-00	E - 12	5GM-84310-20	E - 7	90109-084F7	D - 5
4YR-2517G-00	D - 6	5CG-26280-01	D - 10	5GM-2836B-01	D - 15	5SJ-82501-10	E - 11	4XV-84312-00	E - 7	90109-10473	D - 12
4HC-25181-00	D - 6	5CG-26290-01	D - 10	5LV-2836B-01	D - 10	5SJ-82501-30	E - 11	4SV-84314-00	E - 7	90110-06202	D - 4
5GM-25319-00	D - 8	5SJ-26311-00	D - 10	5SJ-2836K-00	D - 15	5GM-82509-00	E - 12	8G9-84314-00	E - 7	90111-06015	B - 13
5GM-25321-00-35	D - 8	5SJ-26312-00	D - 10	5GM-2836L-00	D - 15	4BH-82511-09	E - 11	4SV-84314-10	E - 7	90111-06020	B - 13
5GM-25328-00	D - 8	4HC-2637G-00	B - 6	5GM-2836T-00	D - 15	5SJ-82552-10	E - 11	4HC-84347-00	D - 4	90116-08591	B - 15
5GM-25338-00-35	D - 8	5H0-26393-00	D - 10	5GM-28371-00	D - 14	5SJ-82552-20	E - 11	4SV-84347-00	E - 7	90119-05071	E - 12
5RB-25383-00	D - 6	4HC-27111-01	D - 12	5SJ-28372-00	D - 14	5GH-82560-00	B - 8	4SV-84350-00	E - 7	90119-06044	C - 10
5MT-25398-00	D - 6	4HC-27112-00	D - 12	5GM-28379-00	C - 11	5GM-82560-00	B - 8	5GM-84397-00	E - 7	90119-06052	E - 7
	D - 8	58K-27112-02	D - 12		E - 2	5RT-82566-50	E - 10	4HC-84545-00	E - 8	90119-06060	C - 10
5MT-25398-10	D - 6	3VR-27114-00	D - 12	4HC-2837G-00	E - 6	5SJ-82590-10	E - 10	5SJ-84710-00	E - 8		D - 12
	D - 8	4HC-27114-00	D - 12	5GM-2837G-00	D - 14	5SJ-82590-30	E - 10	1A2-84714-41	E - 8	90119-06096	D - 14
5MT-25398-20	D - 6	5GM-27311-00	D - 12	5GM-2837H-00	D - 14	341-82594-00	E - 11	5SJ-84735-00	E - 8	90119-06118	B - 8
	D - 8	5GM-27414-01	D - 12	5RB-28380-10	D - 15	5GM-83310-11	E - 5	4HC-84743-00	E - 8	90119-06163	D - 15
5GM-25683-00	D - 8	5GM-27415-00	C - 9	5GM-2838B-00	D - 15	5GM-83311-00	E - 8	4HC-84744-00	E - 8	90143-06024	E - 9
5SJ-2580U-00	D - 7	5GM-27424-00	C - 9	5GM-2839K-00	D - 14	5GM-83312-00	E - 5	4HC-84770-00	D - 4	90149-06184	C - 10
5GM-2580W-01	D - 9		D - 12	5GM-2839M-00	D - 4	5GM-83313-00	E - 5	3Y6-85130-02	E - 8	90150-05024	D - 15
5EB-25828-00	D - 9	5GM-27445-00	C - 9	5GM-28415-00	D - 14	5GM-83320-11	E - 5	JT2-85700-00	E - 12	90153-06029	B - 2
5GM-25828-00	D - 9	5GM-27452-00	C - 9	5GM-28416-00	D - 14	5GM-83322-00	E - 5	5GM-85752-00	E - 12	90154-06014	C - 10
4HC-2582T-00	D - 7	5GM-27453-00	D - 12	5GM-28435-00	D - 14	32H-83331-00	E - 5	4US-85753-00	E - 12	90157-04088	C - 6
5GM-2582W-00	D - 9	5GM-27462-00	C - 9	5GM-2849E-00	D - 12	3GM-83350-01	E - 12	2JG-85757-00	E - 12	90157-05079	E - 10
5RB-2583T-00	D - 11	5GM-27463-01	D - 13	5GM-81410-00	E - 3	3TB-83371-01	E - 12	5GM-85885-00	B - 12	90159-05028	D - 10
5CG-2583T-A4	D - 11	5GM-27475-00	D - 13	5GM-81450-00	E - 3	5GM-81450-00	E - 12	1JL-W0041-01	D - 11	90167-05003	C - 3
5CG-25844-00	D - 11	5GM-27476-00	D - 13	5GM-81677-00	D - 11	5SJ-83500-01	E - 6	5CG-W0041-10	D - 11	90167-05079	C - 11
5SJ-2584A-10	D - 11	5GM-27481-01	D - 12	5GM-81815-00	E - 4	5SJ-83500-51	E - 6	4HM-W0045-00	D - 7		D - 10
3RW-25852-00	D - 11	5GM-27482-00	D - 13	3WP-81826-00	E - 4	5SJ-83509-00	E - 6	5GM-W0046-00	D - 9		D - 14
4GY-25852-01	D - 11	5GM-27483-00	D - 13	4XV-8182A-00	E - 4	5SJ-8350F-00	E - 6	4FU-W0047-00	D - 7	90167-05080	D - 10
3RW-25854-00	D - 11	5GM-27484-00	D - 13	3KS-81840-00	E - 4	5SJ-83510-01	E - 6	4TT-W0047-00	D - 9	90170-06010	E - 9
4L0-25862-01	D - 11	5GM-27485-00	D - 12	11H-81844-00	E - 4	5SJ-83510-51	E - 6	51L-W0048-00	D - 7	90170-06128	B - 4

NUMERICAL INDEX

PART NO.	GRID NO.	PART NO.	GRID NO.	PART NO.	GRID NO.	PART NO.	GRID NO.	PART NO.	GRID NO.	PART NO.	GRID NO.
90170-16425	B - 3	90269-08066	D - 14	90464-20258	D - 10	91317-08030	C - 15	93440-10085	B - 2	95817-10045	C - 9
90170-20386	C - 15	90280-03017	C - 15	90464-23199	B - 6	92017-06012	B - 13	93603-12221	B - 9	95817-10050	B - 13
90170-36279	C - 7	90280-05013	B - 3	90464-25098	E - 12	92017-06025	B - 9	93603-22028	B - 6	95817-12120	C - 9
90176-06003	D - 4	90338-08174	B - 10	90465-13152	D - 10	92907-05600	E - 12		B - 9	95827-06012	D - 2
90176-08026	B - 2	90338-10150	D - 8	90465-14310	D - 6	92907-06200	B - 13	93604-10011	B - 5	95827-08030	C - 13
90179-05523	D - 15	90338-11125	D - 4	90467-07138	B - 14	92907-06600	C - 3	93900-00022	D - 6	95827-10035	C - 13
90179-14469	C - 6	90340-12059	B - 15	90467-08003	C - 12		E - 10	93900-00025	D - 8	97007-05012	B - 7
90179-25615	C - 15	90387-064W3	B - 10	90467-09006	B - 14	93101-10090	B - 6	94111-1214N	D - 6	97007-06012	B - 5
90183-04027	D - 14	90387-06500	D - 4	90467-10008	B - 10	93101-14092	C - 3	94113-1204P	D - 8	97607-30214	E - 6
90183-05004	D - 15	90387-065J6	D - 14		C - 12	93101-28139	C - 6	94581-63104	B - 5	97702-40114	E - 8
90183-05042	C - 10	90387-067N5	D - 15	90467-10038	B - 7	93102-22014	D - 6	94701-00333	B - 2	97702-40912	E - 7
	C - 12	90387-0714B	B - 8		D - 2		D - 8	95024-06010	B - 7	97707-40010	D - 12
	D - 4	90387-1006J	B - 15	90467-11032	B - 10	93102-25299	C - 8	95027-06008	E - 10	97707-40016	E - 6
	D - 10	90387-151R0	D - 6	90467-12053	D - 2	93102-30284	B - 15	95027-06012	D - 2	97707-40512	D - 12
	D - 12	90387-15423	C - 13	90467-13062	B - 13	93102-32298	C - 8	95027-06016	E - 12		D - 14
	D - 15	90387-154E1	C - 13	90467-13064	B - 2	93104-41119	C - 6	95027-06020	B - 2	97707-50012	C - 11
	E - 8	90387-155F2	C - 13	90467-16181	B - 13	93106-26005	C - 13	95027-06030	B - 6		D - 2
90183-06053	D - 15	90387-1906E	C - 6	90467-16195	B - 14	93109-28043	C - 13	95027-06035	B - 6		D - 13
90185-10110	D - 12	90401-10159	D - 11	90467-22100	B - 7		D - 8	95027-06040	C - 3		D - 15
90185-10154	C - 9	90430-06014	B - 2	90467-26131	B - 7	93210-09165	B - 4	95027-06070	B - 15	97707-50014	E - 6
90185-12072	C - 9		B - 6	90468-12069	B - 3	93210-14104	B - 15	95027-06100	B - 15	97707-50016	C - 10
90185-14163	D - 8	90430-08119	B - 15	90468-18121	D - 5	93210-15171	B - 5	95027-06120	B - 2		C - 11
90185-14166	D - 6	90430-12213	B - 15	90480-01288	C - 12	93210-16275	B - 6	95027-08040	B - 15		D - 4
90201-047R9	C - 6	90445-057G5	D - 14	90480-01558	D - 2		B - 15		C - 14		D - 12
90201-05725	C - 11	90445-135J8	B - 15	90480-10332	B - 13	93210-16325	C - 4	95607-06100	E - 9		D - 14
90201-06057	D - 4	90446-11303	B - 10	90480-12237	D - 2	93210-19123	C - 3	95607-06200	B - 14		E - 5
	D - 15	90450-28014	B - 7	90480-13398	D - 14	93210-27672	C - 2	95607-08200	B - 13	97707-50125	B - 10
90201-06380	B - 14	90450-60001	B - 10	90480-13598	B - 10	93210-33133	B - 6	95617-06615	B - 2	97801-05010	B - 11
90201-08512	B - 6	90460-15126	D - 10	90480-14323	B - 7	93210-35520	B - 9	95617-08620	B - 2	97801-05014	B - 12
	B - 9	90464-05141	E - 9	90480-16301	B - 8	93210-35537	B - 10	95702-05500	E - 8	98501-04012	B - 11
90201-08609	B - 2	90464-05188	C - 15	90501-10312	E - 9	93210-43713	C - 6	95704-06500	D - 15	98507-05008	D - 10
90201-086J0	D - 14		D - 11	90501-14001	B - 7	93210-57634	B - 2	95707-06500	B - 10	98507-05010	D - 5
90201-08784	D - 5	90464-07001	D - 2	90501-18576	B - 9	93210-92448	B - 2		D - 2	98507-05016	E - 12
90201-10118	D - 11		E - 10	90501-505J6	C - 6	93211-17733	C - 6	95707-08500	C - 9	98507-05045	E - 9
90201-10591	B - 5	90464-08051	D - 6	90506-18224	D - 12	93306-00006	B - 6		D - 4	98507-05050	E - 9
90201-105A2	C - 9	90464-09008	D - 2	90506-20158	D - 12	93306-00518	B - 5	95807-06008	B - 7	98507-06020	C - 3
	C - 13	90464-10190	E - 10	90506-26001	D - 12	93306-20204	B - 5	95807-06010	B - 7	98507-06025	E - 10
90201-12166	C - 5	90464-11003	E - 10	90506-40175	D - 12	93306-20570	C - 8		E - 12	98901-04006	B - 11
90201-144M8	C - 6	90464-11004	B - 14	90560-08326	D - 4	93306-27205	C - 8	95807-06012	C - 9	98907-03008	E - 11
90201-156R4	C - 8	90464-13001	B - 10	91317-05012	E - 3	93306-30201	C - 8		C - 15	99001-04600	D - 12
90201-160F6	B - 3	90464-13073	E - 10	91317-06014	B - 5	93306-30212	C - 13	95807-06014	B - 14	99001-06600	B - 9
90201-16242	B - 15	90464-14134	E - 11		B - 15		D - 6	95807-06020	B - 13	99001-07600	B - 6
90201-220J8	D - 8	90464-15192	E - 10	91317-06016	B - 6		D - 8		D - 11	99001-08600	C - 6
90201-232K5	C - 8	90464-15195	D - 10	91317-06020	B - 7	93306-30321	C - 8	95807-06025	C - 13	99009-10400	B - 6
90202-26142	C - 15		E - 10	91317-06025	D - 11	93306-90603	C - 2	95807-08016	C - 9	99009-12400	C - 5
90208-21001	C - 8	90464-18246	D - 14	91317-06030	E - 3	93311-41566	C - 8	95817-06025	E - 4	99009-16400	B - 15
90208-25001	C - 8		E - 12	91317-06035	B - 6	93399-99942	C - 14	95817-08016	B - 15	99009-25400	C - 8
90215-06184	B - 5	90464-20181	E - 10	91317-08016	C - 5	93430-12008	D - 12	95817-08070	C - 13	99246-00080	C - 12

NUMERICAL INDEX

PART NO.	GRID NO.	PART NO.	GRID NO.	PART NO.	GRID NO.	PART NO.	GRID NO.	PART NO.	GRID NO.
99247-00080	C - 12								
99530-10114	B - 2								
	B - 15								
	C - 3								
99530-14016	B - 2								