

PARTS CATALOGUE

YP250 (5GM9) EUROPE

YAMAHA
GENUINE
Parts & Accessories

115GM-300E1

YP250
PARTS CATALOGUE
©2001 by Yamaha Motor Co., Ltd.
1st Edition, Jan. 2001
All rights reserved.
Any reprinting or unauthorized use
without the written permission of
Yamaha Motor Co., Ltd.
is expressly prohibited.
Printed in Japan

A3



A4

FOREWORD

This Parts Catalogue is related to the parts for the model(s) in the below frame. When you are ordering replacement parts, please refer to this Parts Catalogue and quote both part numbers and part names correctly.

YP250(5GM9)

1. Modifications or additions which have been made after issue of the Parts Catalogue will be announced in the Yamaha Parts News. It is advisable that you make necessary corrections to the Parts Catalogue according to the Yamaha Parts News.

2. Abbreviations

The Following abbreviations are used in this Parts Catalogue.

“UR” Use specified parts number.

“UN” Use as many as needed.

“AP” Alternate Parts

“LM” Local Made (Parts need to be ordered locally)

“F#” Frame No. (Applicable machine No.)

3. Parts, which are to be supplied in an assembly, are listed with a dot(.) in front of the part name as shown below.

EXAMPLE

CARBURETOR ASSY

.JET, PILOT

.NOZZLE, MAIN

4. Number of component for assembly

The numeral appearing to the right of each component part indicates the quantity of parts for each assembly unit.

EXAMPLE

PART NO.	DESCRIPTION	Q'TY	REMARKS
2F5-83310-60	FRONT FLASHER LIGHT ASSY	2	
115-83311-60	.BULB (6V-18W)	1	
1M1-83309-60	.REFLECTOR	1	

5. Applicable colors of graphics are represented in the “REMARKS” as shown below.

PART NO.	DESCRIPTION	Q'TY	REMARKS
2N4-24110-00-X5	FUEL TANK COMP.	1	MXR
3J1-24240-10	.GRAPHIC, FUEL TANK	1	FOR MXR

6. Applicable Serial No.

Engine Serial No.

Frame Serial No.

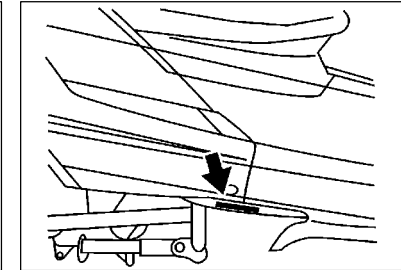
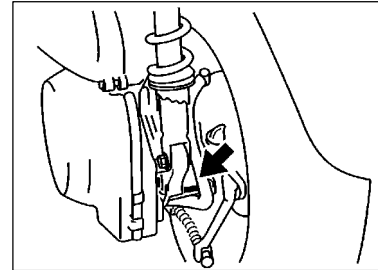

7. Note that the illustrations for reference in finding parts numbers, not to be used for assembling. When assembling, please use the applicable service manual.

8. The asterisk (*) before a reference number indicates modification items after the first edition.

MODEL LABEL

(1) A label called "Model Label" is affixed in the location as indicated in (3) below.
When using this parts catalogue, please be sure to cross-refer the "model code – production code No." in the catalogue to the "model code – production code No." indicated on the Model Label affixed onto the product concerned.

(2) "Model Label" Indication

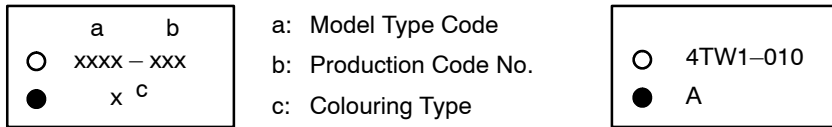

(3) Model Label Affixing Location

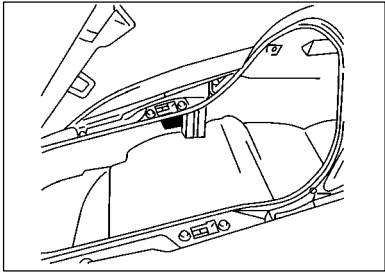

(4) Model Code – Production Code Number of Model Listed in This Parts Catalog

Model Code	Production Code No.	Country (destination)	Model Code	Production Code No.	Country (destination)
5GM9	020	BELGIUM			
	030	SWITZERLAND			
	060	ENGLAND			
	070	GREECE			
	080	ITALY			
	081				
	090	HOLLAND			
	100	NORWAY			
	110	PORTUGAL			
120	SWEDEN				

(5) Colouring Information

Model Code	Colouring type code	Colour code	Colour Name	Abbreviation
5GM9	A	000L	MARBLE SILVER	MAS
	B	0627	VERY DARK BLUE COCKTAIL 4	VDBC4
	C	00JY	MIYABI MAROON	MYM
	D	0781	VERY DARK BLUE METALLIC A	VDBMA

FIG. 1 CYLINDER

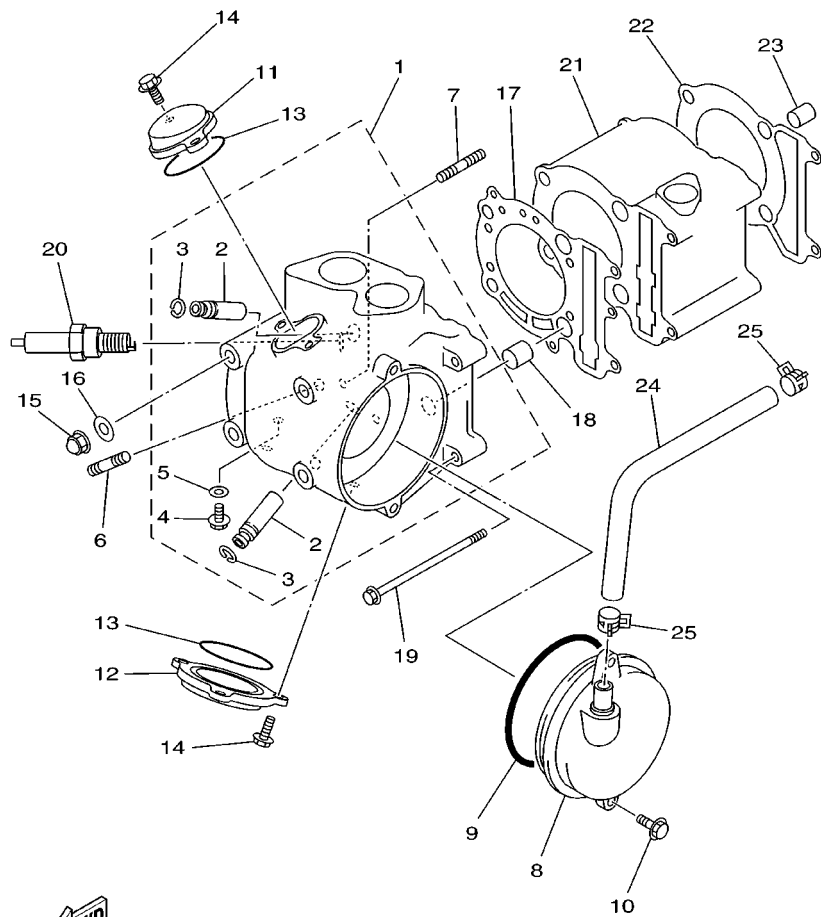

5GM1010-0010

REF. NO.	PART NO.	DESCRIPTION	5GM9				REMARKS
1	5GM-11101-00	CYLINDER HEAD ASSY	1				
2	4G0-11133-10	.GUIDE, INTAKE VALVE	2				
3	93440-10085	.CIRCLIP	2				
4	90153-06029	.SCREW, HEXAGON	1				
5	90430-06014	.GASKET	1				
6	95617-08620	BOLT, STUD	2				
7	95617-06615	BOLT, STUD	2				
8	4HC-11160-00	BREATHER ASSY	1				
9	93210-92448	O-RING	1				
10	95027-06020	BOLT, FLANGE	2				
11	3GC-11186-00	COVER, CYLINDER HEAD SIDE 2	1				
12	3GC-11187-00	COVER, CYLINDER HEAD SIDE 3	1				
13	93210-57634	O-RING	2				
14	95027-06020	BOLT, FLANGE	5				
15	90176-08026	NUT, CROWN	4				
16	90201-08609	WASHER, PLATE	4				
17	4HC-11181-01	GASKET, CYLINDER HEAD 1	1				
18	99530-14016	PIN, DOWEL	2				
19	95027-06120	BOLT, FLANGE	2				
20	94701-00333	PLUG, SPARK (NGK DR8EA)	1				
21	4HC-11311-00	CYLINDER 1	1				
22	4HC-11351-00	GASKET, CYLINDER	1				
23	99530-10114	PIN, DOWEL	2				
24	4HC-11166-00	PIPE, BREATHER 1	1				
25	90467-13064	CLIP	2				

FIG. 2 CRANKSHAFT. PISTON

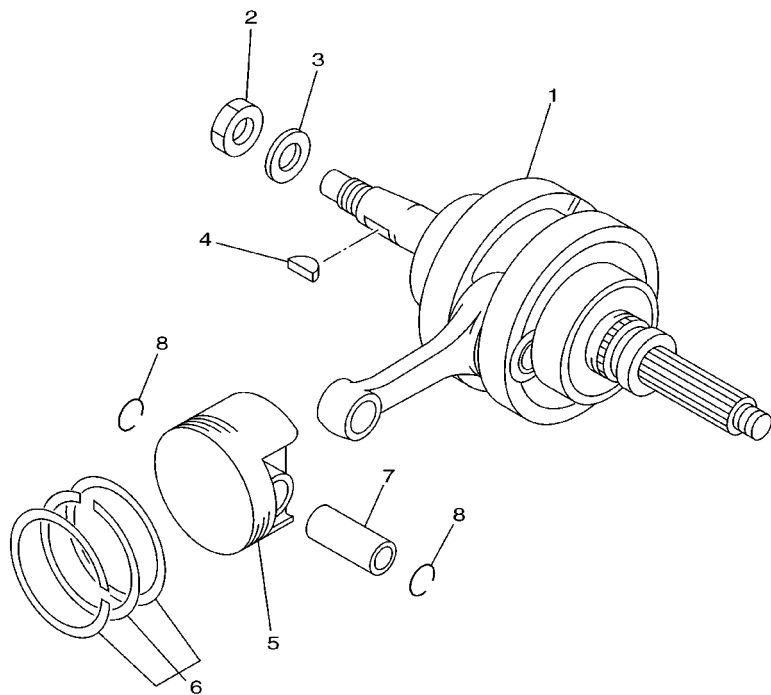

REF. NO.	PART NO.	DESCRIPTION	5GM9				REMARKS
1	5GM-11400-00	CRANKSHAFT ASSY	1				
2	90170-16425	NUT	1				
3	90201-160F6	WASHER, PLATE	1				
4	90280-05013	KEY, WOODRUFF	1				
5	4HC-11631-01	PISTON (STD)	1				
	4HC-11636-01	PISTON (0.50MM O/S)	1				AP
	4HC-11638-01	PISTON (1.00MM O/S)	1				AP
6	4HC-11603-00	PISTON RING SET (STD)	1				
	4HC-11605-00	PISTON RING SET (0.50MM O/S)	1				AP
	4HC-11607-00	PISTON RING SET (1.00MM O/S)	1				AP
7	4JH-11633-00	PIN, PISTON	1				
8	90468-12069	CLIP	2				



5GM1010-0020

FIG. 3 VALVE

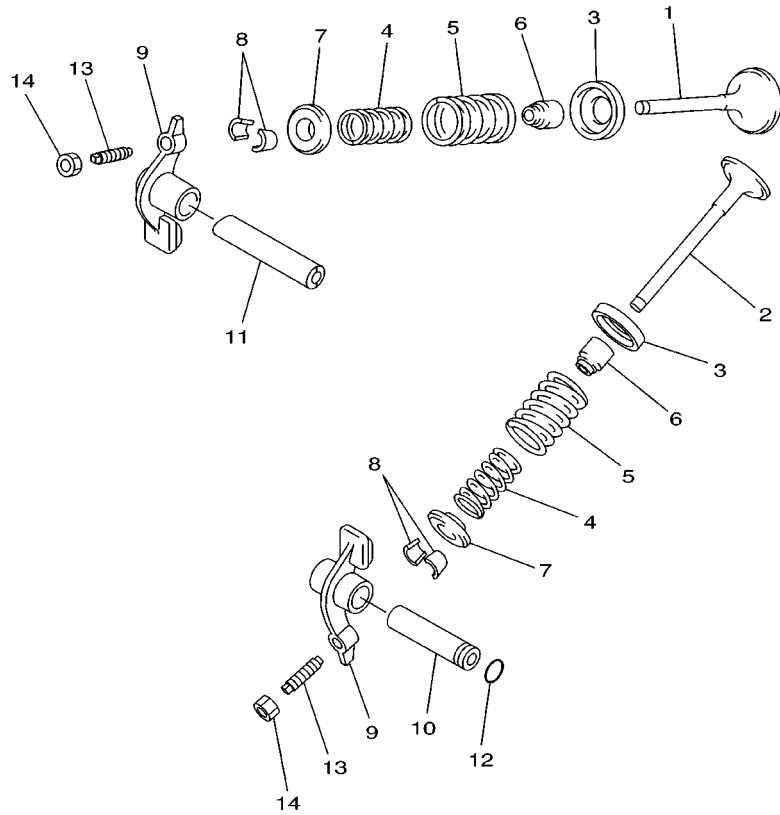

REF. NO.	PART NO.	DESCRIPTION	5GM9				REMARKS
1	5GM-12111-00	VALVE, INTAKE	1				
2	5H0-12121-01	VALVE, EXHAUST	1				
3	4G0-12116-01	SEAT, VALVE SPRING	2				
4	4HC-12113-00	SPRING, VALVE INNER	2				
5	4HC-12114-00	SPRING, VALVE OUTER	2				
6	5H0-12119-00	SEAL, VALVE STEM	2				
7	4G0-12117-00	RETAINER, VALVE SPRING	2				
8	4G0-12118-00	COTTER, VALVE	4				
9	36X-12151-00	ARM, VALVE ROCKER	2				
10	3Y1-12156-00	SHAFT, ROCKER 2	1				
11	5H0-12146-00	SHAFT, ROCKER	1				
12	93210-09165	O-RING	1				
13	2NX-12159-00	SCREW, VALVE ADJUSTING	2				
14	90170-06128	NUT	2				



4HC1010-5030

FIG. 4 CAMSHAFT. CHAIN

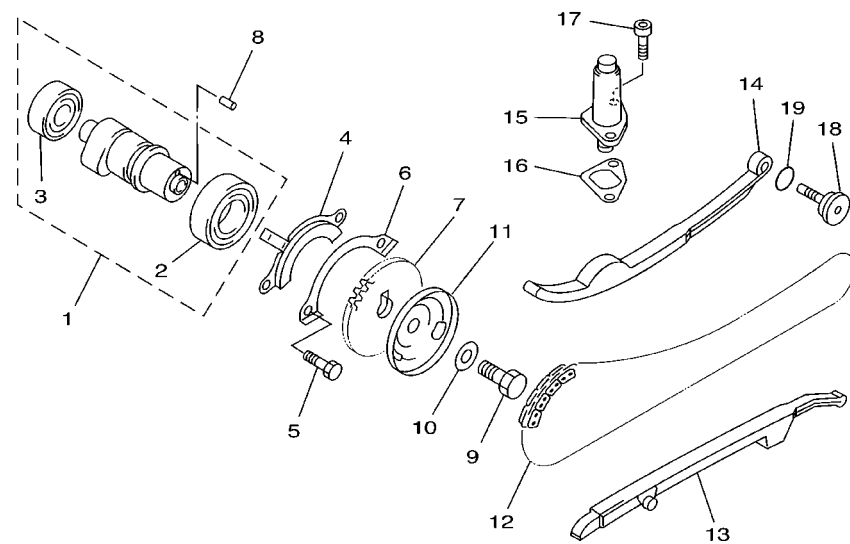

REF. NO.	PART NO.	DESCRIPTION	5GM9				REMARKS
1	4HC-12170-00	CAMSHAFT ASSY 1	1				
2	93306-00518	.BEARING	1				
3	93306-20204	.BEARING (B6202Z)	1				
4	4GA-1111F-00	PLATE	1				
5	97007-06012	BOLT	2				
6	90215-06184	WASHER, LOCK	1				
7	4HC-12176-00	SPROCKET, CAM CHAIN	1				
8	93604-10011	PIN, DOWEL	1				
9	90101-10303	BOLT	1				
10	90201-10591	WASHER, PLATE	1				
11	4KB-11145-00	PLATE, BREATHER 2	1				
12	94581-63104	CHAIN	1				
13	4HC-12231-00	GUIDE, STOPPER 1	1				
14	4HC-12241-00	GUIDE, STOPPER 2	1				
15	2UJ-12210-01	TENSIONER ASSY, CAM CHAIN	1				
16	4RF-12213-00	GASKET, TENSIONER CASE	1				
17	91317-06014	BOLT	2				
18	4HC-12157-00	BOLT	1				
19	93210-15171	O-RING	1				



4HC1010-5040

FIG. 5 WATER PUMP

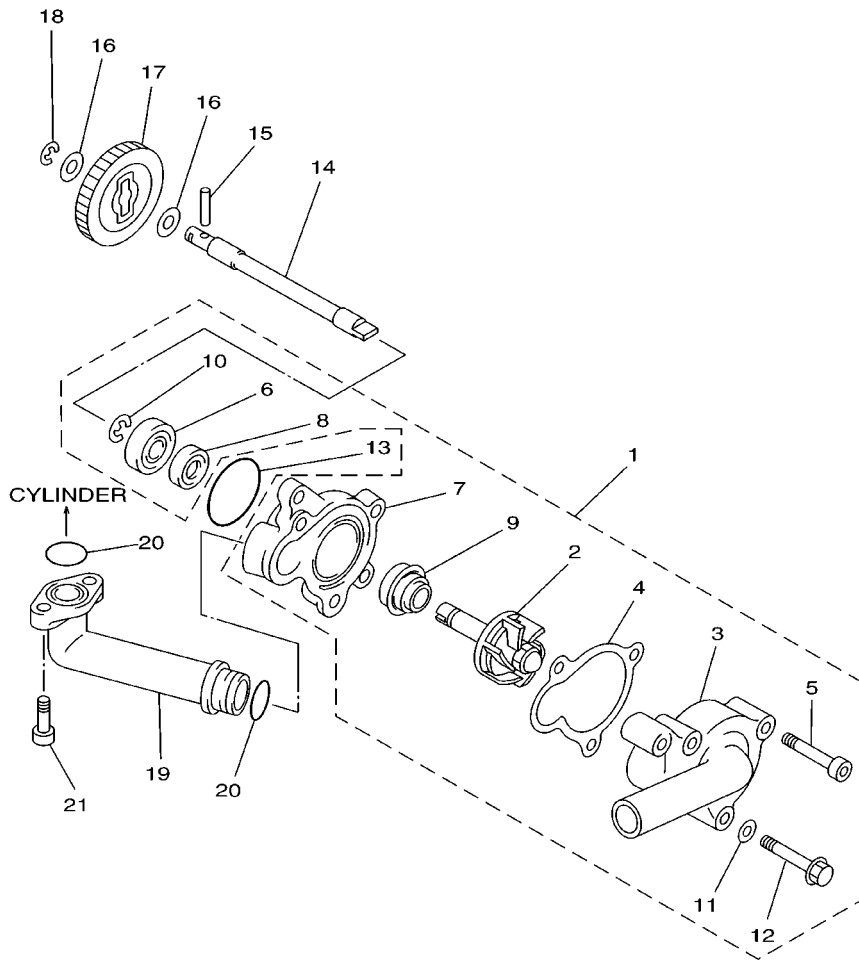

REF. NO.	PART NO.	DESCRIPTION	5GM9	REMARKS
1	5GM-12420-01	WATER PUMP ASSY	1	
2	5GM-12450-01	.IMPELLER SHAFT ASSY	1	
3	4HC-12422-01	.COVER, HOUSING	1	
4	4HC-12428-10	.GASKET, HOUSING COVER 2	1	
5	91317-06035	.BOLT	2	
6	93306-00006	.BEARING (B6000)	1	
7	4HC-12421-00	.HOUSING, WATER PUMP	1	
8	93101-10090	.OIL SEAL	1	
9	11H-12438-00	.SEAL, MECHANICAL	1	
10	99009-10400	.CIRCLIP	1	
11	90430-06014	.GASKET	1	
12	95027-06035	.BOLT, FLANGE	1	
13	93210-33133	O-RING	1	
14	5GM-12426-00	SHAFT	1	
15	93603-22028	PIN, DOWEL	1	
16	90201-08512	WASHER, PLATE	2	
17	4HC-12459-00	GEAR, IMPELLER SHAFT	1	
18	99001-07600	CIRCLIP	1	
19	4HC-12446-00	JOINT	1	
20	93210-16275	O-RING	2	
21	91317-06016	BOLT	2	



5GM1010-0050

FIG. 6 RADIATOR. HOSE

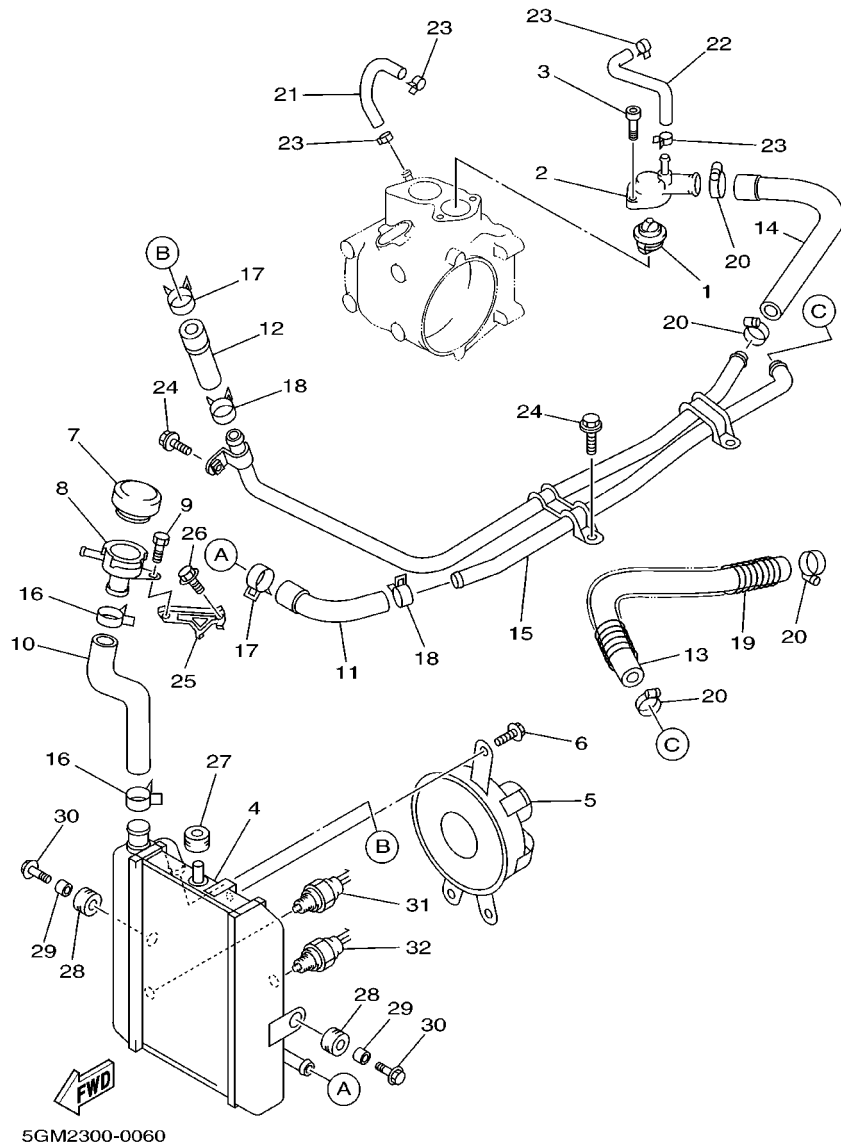

REF. NO.	PART NO.	DESCRIPTION	5GM9				REMARKS
1	4HC-12411-00	THERMOSTAT	1				
2	4HC-12413-00	COVER, THERMOSTAT	1				
3	91317-06020	BOLT	2				
4	5GM-12461-10	RADIATOR ASSY	1				
5	5GM-12405-00	BLOWER ASSY	1				
6	95024-06010	BOLT, FLANGE	3				
7	4JH-12462-00	CAP, RADIATOR	1				
8	4HC-12591-00	SUPT, FILLER NECK	1				
9	97007-05012	BOLT	1				
10	5GM-12481-00	PIPE 1	1				
11	5GM-12482-00	PIPE 2	1				
12	5GM-12483-00	PIPE 3	1				
13	5GM-12484-00	PIPE 4	1				
14	5GM-12485-00	PIPE 5	1				
15	5GM-12476-00	PIPE 6	1				
16	90467-26131	CLIP	2				
17	90467-23177	CLIP	2				
18	90467-22100	CLIP	2				
19	90501-14001	SPRING, COMPRESSION	1				
20	90460-27219	CLAMP, HOSE	4				
21	4HC-12576-00	HOSE 1	1				
22	4HC-12577-00	HOSE 2	1				
23	90467-10038	CLIP	4				
24	95807-06010	BOLT, FLANGE	3				
25	5GM-12443-00	STAY	1				
26	95807-06008	BOLT, FLANGE	1				
27	90480-14323	GROMMET	1				

FIG. 6 RADIATOR. HOSE

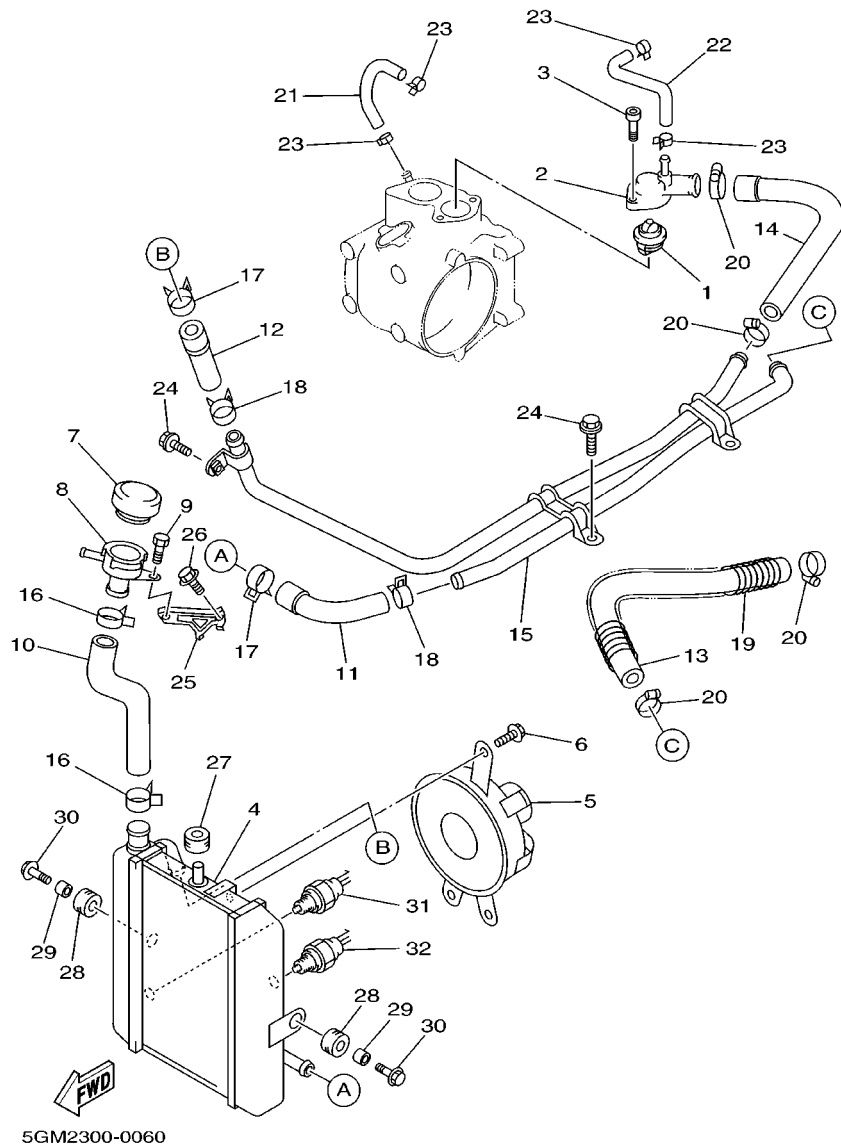

REF. NO.	PART NO.	DESCRIPTION	5GM9				REMARKS
28	90480-16301	GROMMET	2				
29	90387-0714B	COLLAR	2				
30	90119-06118	BOLT, WITH WASHER	2				
31	5GM-82560-00	THERMO SWITCH ASSY	1				
32	5GH-82560-00	THERMO SWITCH ASSY	1				

FIG. 7 OIL PUMP

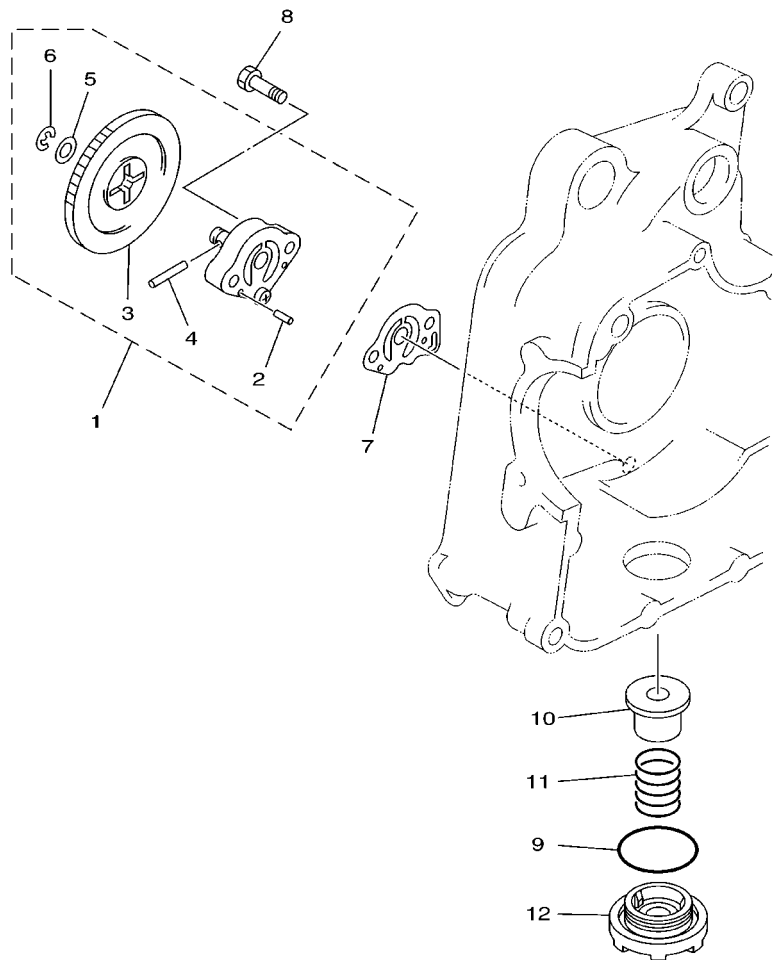

REF. NO.	PART NO.	DESCRIPTION	5GM9					REMARKS
1	4HC-13300-00	OIL PUMP ASSY	1					
2	93603-12221	.PIN, DOWEL	2					
3	4HC-13325-00	.GEAR, PUMP DRIVEN	1					
4	93603-22028	.PIN, DOWEL	1					
5	90201-08512	.WASHER, PLATE	1					
6	99001-06600	.CIRCLIP	1					
7	4HC-13475-00	GASKET	1					
8	92017-06025	BOLT, BUTTON HEAD	2					
9	51Y-13411-00	STRAINER, OIL	1					
10	90501-18576	SPRING, COMPRESSION	1					
11	4HC-15351-00	PLUG, DRAIN	1					
12	93210-35520	O-RING	1					

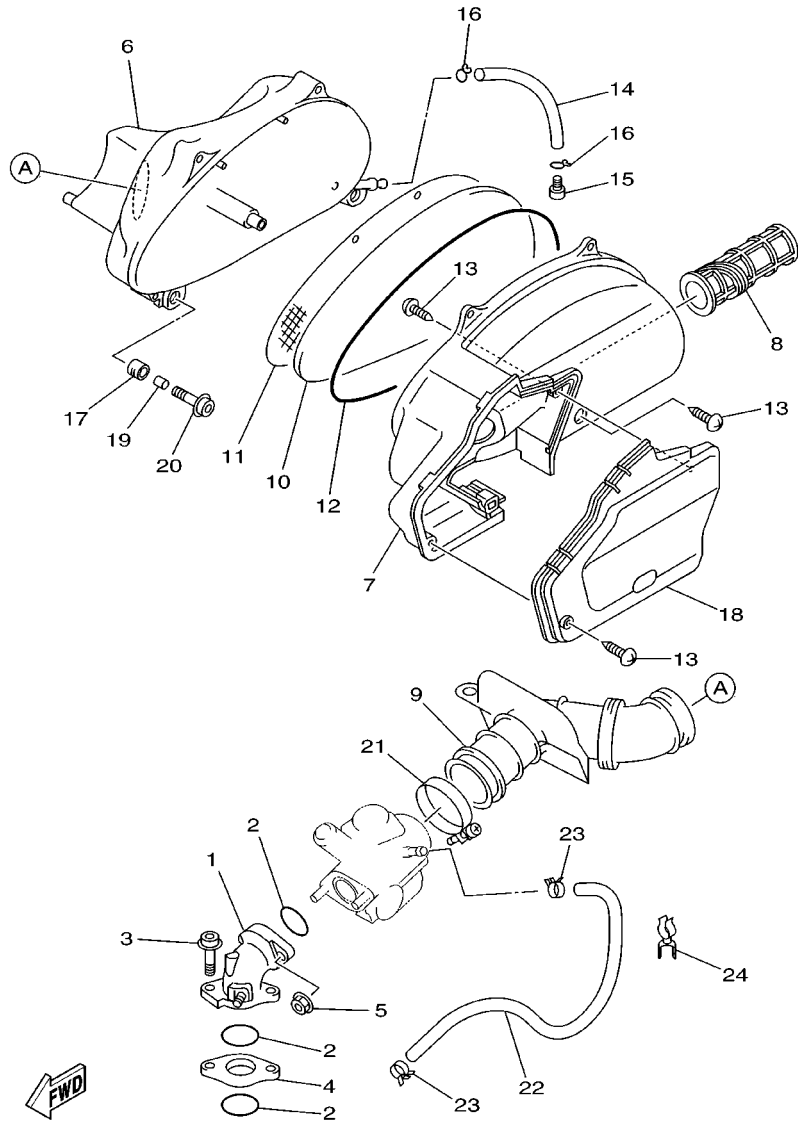

5GM1010-0070



5GM1010-0080

FIG. 8 INTAKE

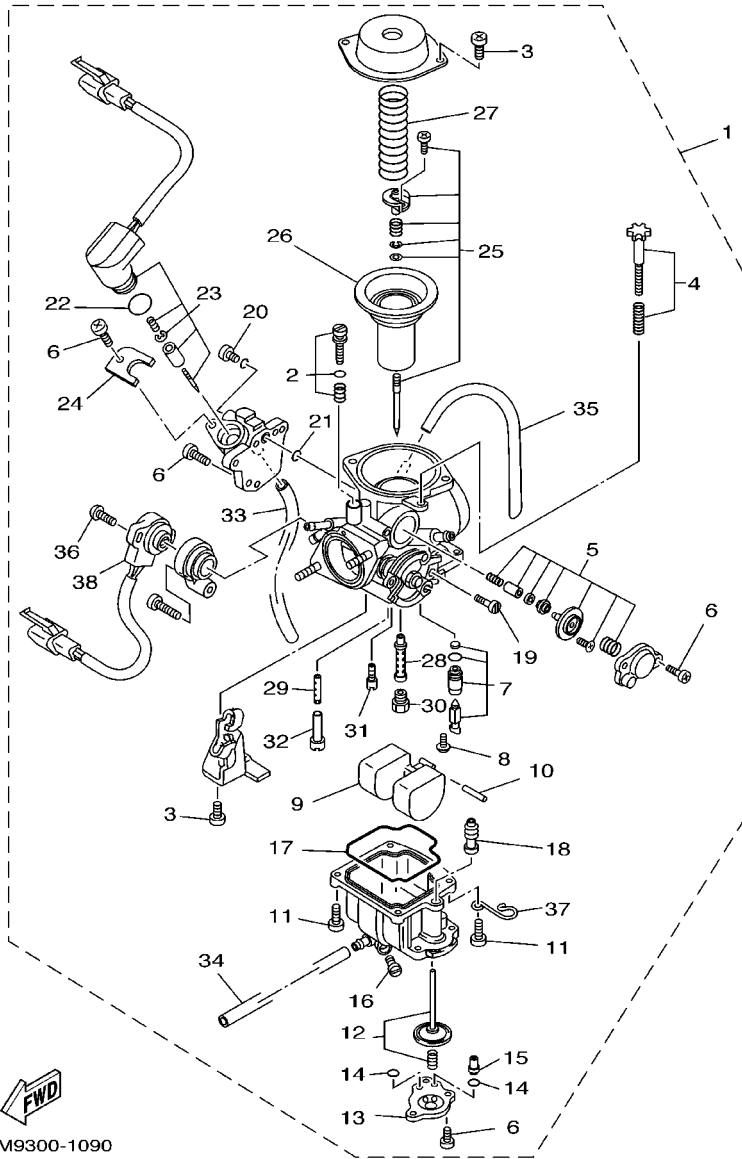
REF. NO.	PART NO.	DESCRIPTION	5GM9				REMARKS
1	4HC-13586-11	JOINT, CARBURETOR 1	1				
2	93210-35537	O-RING	3				
3	90109-067E6	BOLT	2				
4	4HC-13595-00	JOINT	1				
5	95707-06500	NUT, FLANGE	2				
6	4HC-14411-00	CASE, AIR CLEANER 1	1				
7	5GM-14412-01	CAP, CLEANER CASE 1	1				
8	5GM-14437-00	DUCT	1				
9	4HC-14453-01	JOINT, AIR CLEANER 1	1				
10	4HC-14451-00	ELEMENT, AIR CLEANER	1				
11	4HC-14472-00	PLATE, ELEMENT	1				
12	4HC-14452-00	SEAL	1				
13	97707-50125	SCREW, TAPPING	7				
14	90446-11303	HOSE	1				
15	90338-08174	PLUG	1				
16	90467-10008	CLIP	2				
17	90480-13598	GROMMET	2				
18	5GM-1441A-00	COVER, CLEANER CASE 1	1				
19	90387-064W3	COLLAR	2				
20	90109-067E6	BOLT	2				
21	90450-60001	HOSE CLAMP ASSY	1				
22	5GM-14294-00	HOSE	1				
23	90467-11032	CLIP	2				
24	90464-13001	CLAMP	1				



5GM9300-1090

FIG. 9 CARBURETOR

REF. NO.	PART NO.	DESCRIPTION	5GM9				REMARKS
1	5GM-14301-10	CARBURETOR ASSY 1	1				
2	5GM-14105-00	.PILOT SCREW SET	1				
3	97801-05010	.SCREW, PAN HEAD	4				
4	4HC-14103-00	.THROTTLE SCREW SET	1				
5	4HC-1490A-00	.DIAPHRAGM SET 1	1				
6	214-24535-00	.SCREW, LEVER FITTING	9				
7	4HC-14390-00	.NEEDLE VALVE ASSY	1				
8	98901-04006	.SCREW, BIND	1				
9	25N-14385-00	.FLOAT	1				
10	4KL-14386-00	.PIN, FLOAT	1				
11	98501-04012	.SCREW, PAN HEAD	4				
12	4HC-1490H-08	.DIAPHRAGM SET 5	1				
13	4HC-14958-00	.COVER, DIAPHRAGM	1				
14	389-14147-00	.O-RING	2				
15	4KL-14272-01	.VALVE, CHECK SEAT	1				
16	4KL-14115-00	.PLUG, DRAIN	1				
17	4KL-14384-00	.GASKET, FLOAT CHAMBER	1				
18	4KL-14404-00	.DUST CUP COMP.	1				
19	4HC-14429-00	.SCREW	1				
20	4HC-14592-00	.SCREW	1				
21	4KL-14536-00	.GASKET	1				
22	4KL-14397-00	.O-RING	1				
23	5GM-1410A-10	.STARTER SET	1				
24	4JP-14243-01	.PLATE	1				
25	5GM-1490J-00	.NEEDLE SET	1				
26	4HC-14340-00	.VALVE ASSY	1				
27	4HC-14286-00	.SPRING	1				

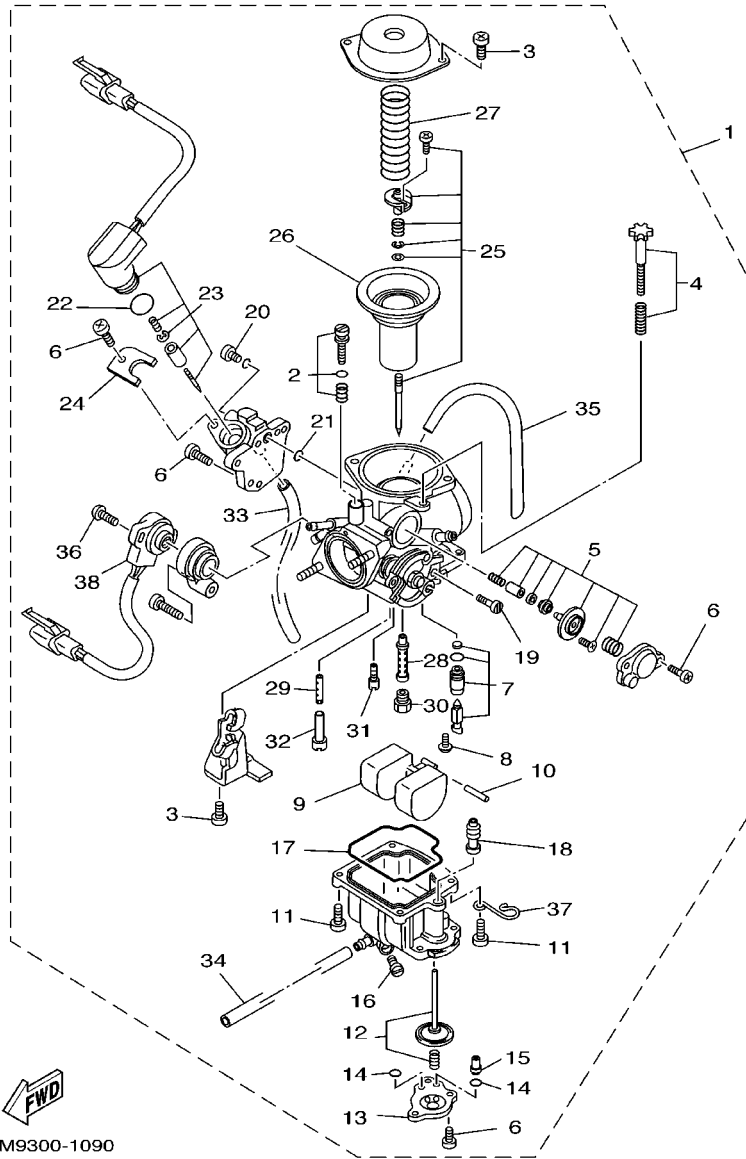

5GM9300-1090

FIG. 9 CARBURETOR

REF. NO.	PART NO.	DESCRIPTION	5GM9				REMARKS
28	4UC-14341-00	.NOZZLE, MAIN	1				
29	4UC-14341-10	.NOZZLE, MAIN	1				
30	50M-14343-64	.JET, MAIN (#128)	1				
31	38V-14342-22	.JET, PILOT (#44)	1				
32	50M-14355-00	.PLUG	1				
33	4HC-14197-00	.PIPE	1				
34	4HC-14196-00	.PIPE	1				
35	5GM-14197-00	.PIPE	1				
36	5GM-14565-00	.SCREW	1				
37	5GM-14243-00	.PLATE	1				
38	5GM-85885-00	.THROTTLE SENSOR ASSY	1				

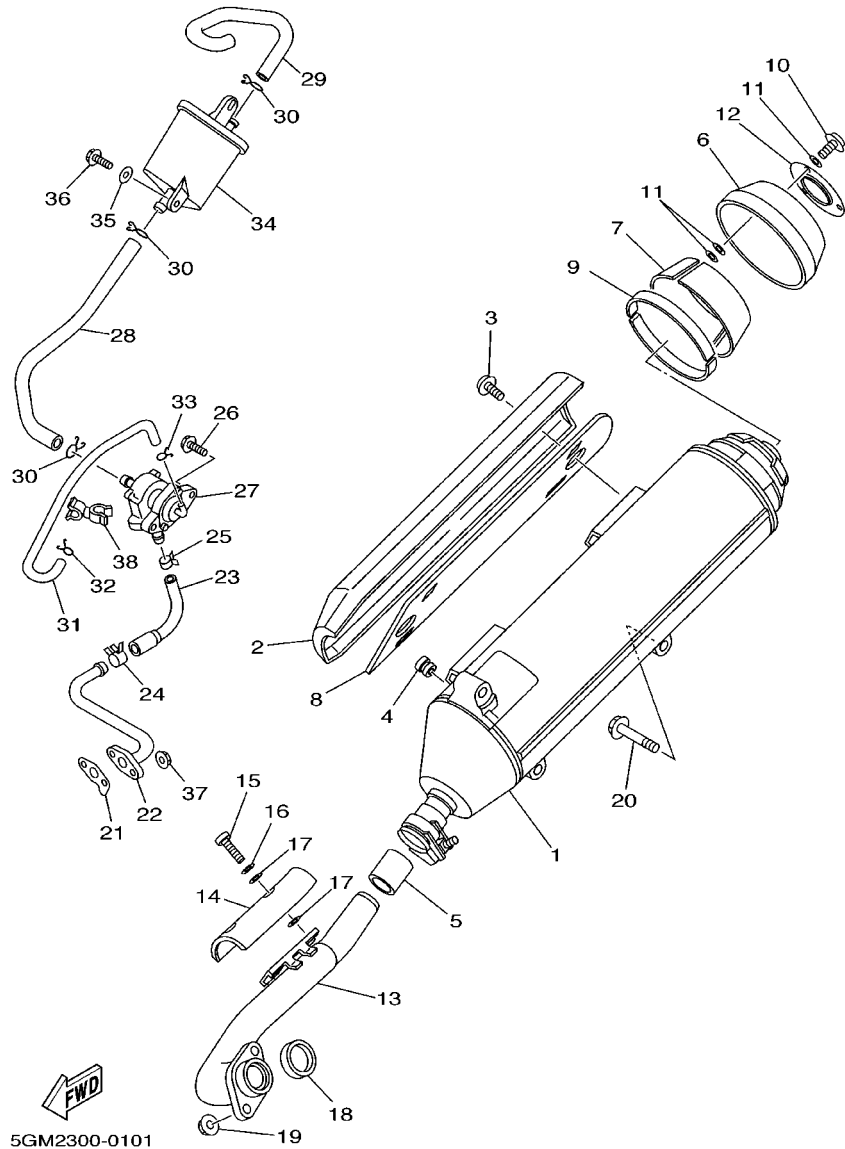
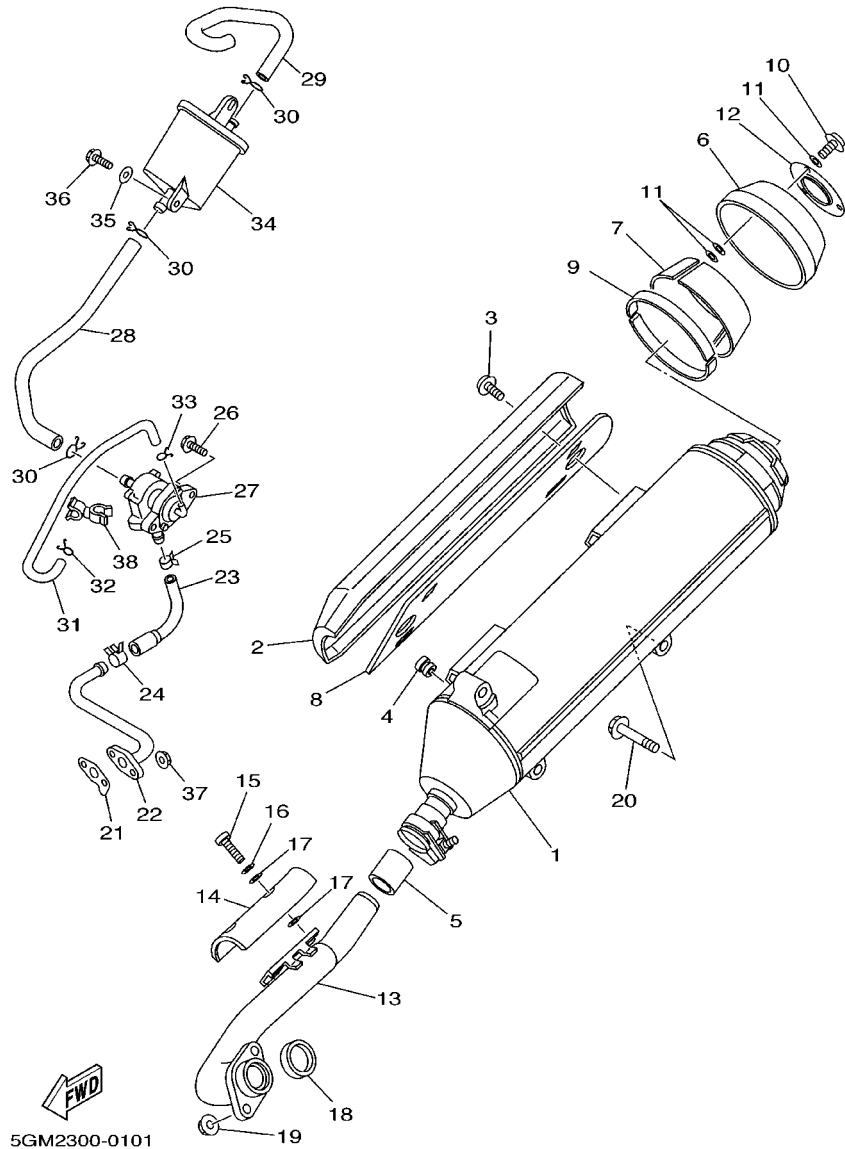

FIG. 10 EXHAUST

REF. NO.	PART NO.	DESCRIPTION	5GM9	REMARKS
1	5GM-14711-01	MUFFLER 1	1	
2	5GM-14718-00	PROTECTOR, MUFFLER 1	1	
3	90111-06015	BOLT	2	
4	90480-10332	GROMMET	2	
5	4BH-14714-00	GASKET, MUFFLER	1	
6	5GM-14799-00	CAP	1	
7	5GM-14728-00	PROTECTOR, MUFFLER 2	2	
8	5GM-14738-00	PROTECTOR, MUFFLER 3	1	
9	5GM-14748-00	PROTECTOR, MUFFLER 4	2	
10	90111-06020	BOLT	3	
11	5GM-14766-00	WASHER, PROTECTOR	9	
12	5GM-1482K-00	PLATE	1	
13	5GM-14611-00	PIPE, EXHAUST 1	1	
14	4HC-14628-00	PROTECTOR, EXHAUST PIPE	1	
15	92017-06012	BOLT, BUTTON HEAD	2	
16	92907-06200	WASHER	2	
17	4BD-14766-00	WASHER, PROTECTOR	4	
18	3MT-14613-00	GASKET, EXHAUST PIPE	1	
19	95607-08200	NUT, SELF-LOCKING	2	
20	95817-10050	BOLT, FLANGE	3	
21	5GM-14815-00	GASKET	1	
22	5GM-14871-01	PIPE 1	1	
23	5GM-14881-00	HOSE, BEND 1	1	
24	90468-08104	CLIP	1	
25	90467-14117	CLIP	1	
26	95807-06020	BOLT, FLANGE	2	
27	5GM-14803-00	AIR INDUCTION SYSTEM ASSY	1	

FIG. 10 EXHAUST



REF. NO.	PART NO.	DESCRIPTION	5GM9				REMARKS
28	5GM-14882-00	HOSE, BEND 2	1				
29	5GM-14883-00	HOSE, BEND 3	1				
30	90467-16195	CLIP	3				
31	5GM-13542-00	HOSE, VACUUM SENSING 1	1				
32	90467-09006	CLIP	1				
33	90467-07138	CLIP	1				
34	5GM-14806-00	AIR FILTER	1				
35	90201-06380	WASHER, PLATE	2				
36	95807-06014	BOLT, FLANGE	2				
37	95607-06200	NUT, SELF U-FLANGE	2				
38	90464-11004	CLAMP	1				

FIG. 11 CRANKCASE

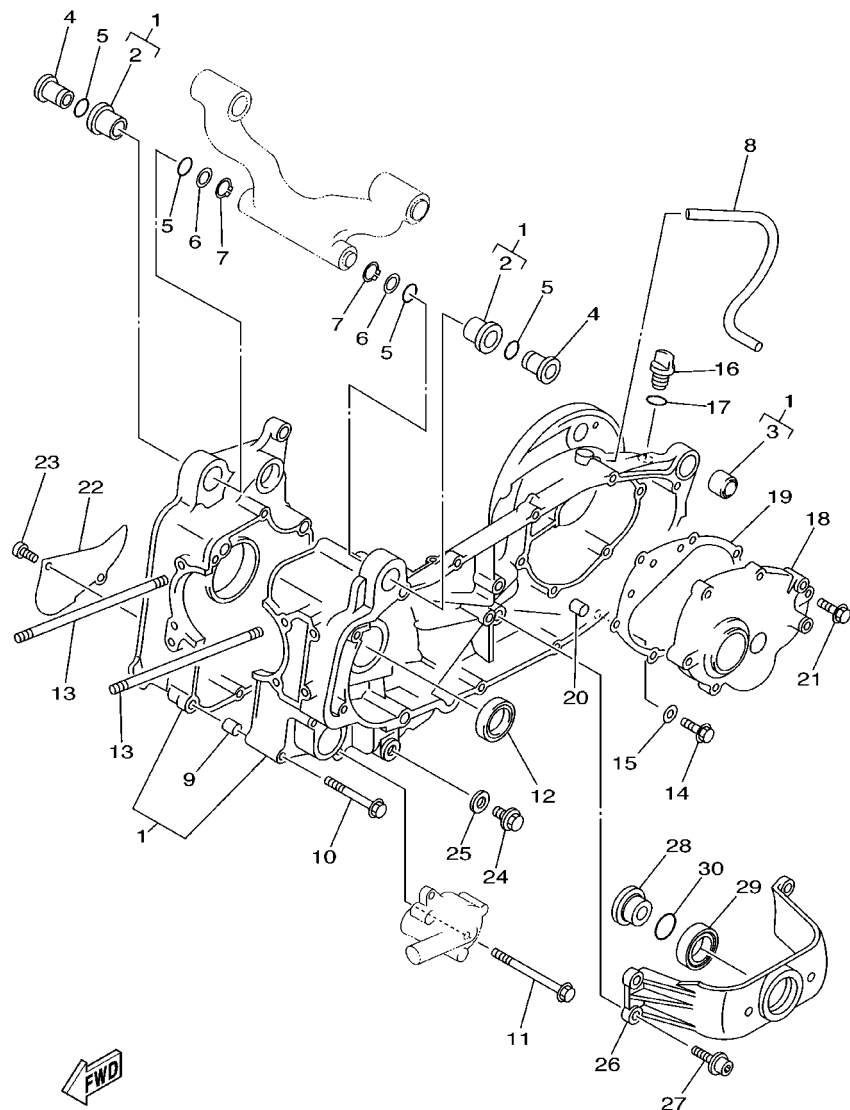

5GM1010-0111

REF. NO.	PART NO.	DESCRIPTION	5GM9				REMARKS
1	5GM-15100-00	CRANKCASE ASSY	1				
2	4HC-15378-00	.HOLDER	2				
3	164-22216-00	.BUSH, REAR SHOCK ABSORBER	1				
4	90387-1006J	COLLAR	2				
5	93210-16275	O-RING	4				
6	90201-16242	WASHER, PLATE	2				
7	99009-16400	CIRCLIP	2				
8	90445-135J8	HOSE (L330)	1				
9	99530-10114	PIN, DOWEL	2				
10	95027-06070	BOLT, FLANGE	4				
11	95027-06100	BOLT, FLANGE	5				
12	93102-30284	OIL SEAL	1				
13	90116-08591	BOLT, STUD	4				
14	95817-08016	BOLT, FLANGE	1				
15	90430-08119	GASKET	1				
16	2T4-15363-00	PLUG, OIL	1				
17	93210-14104	O-RING	1				
18	5GM-15421-00	COVER, CRANKCASE 2	1				
19	4HC-15461-00	GASKET, CRANKCASE COVER 2	1				
20	99530-10114	PIN, DOWEL	2				
21	95027-08040	BOLT, FLANGE	6				
22	4HC-15492-00	COVER	1				
23	91317-06014	BOLT	2				
24	90340-12059	PLUG, STRAIGHT SCREW	1				
25	90430-12213	GASKET	1				
26	5GM-15199-00	BRACKET	1				
27	90109-082F5	BOLT	4				

FIG. 11 CRANKCASE

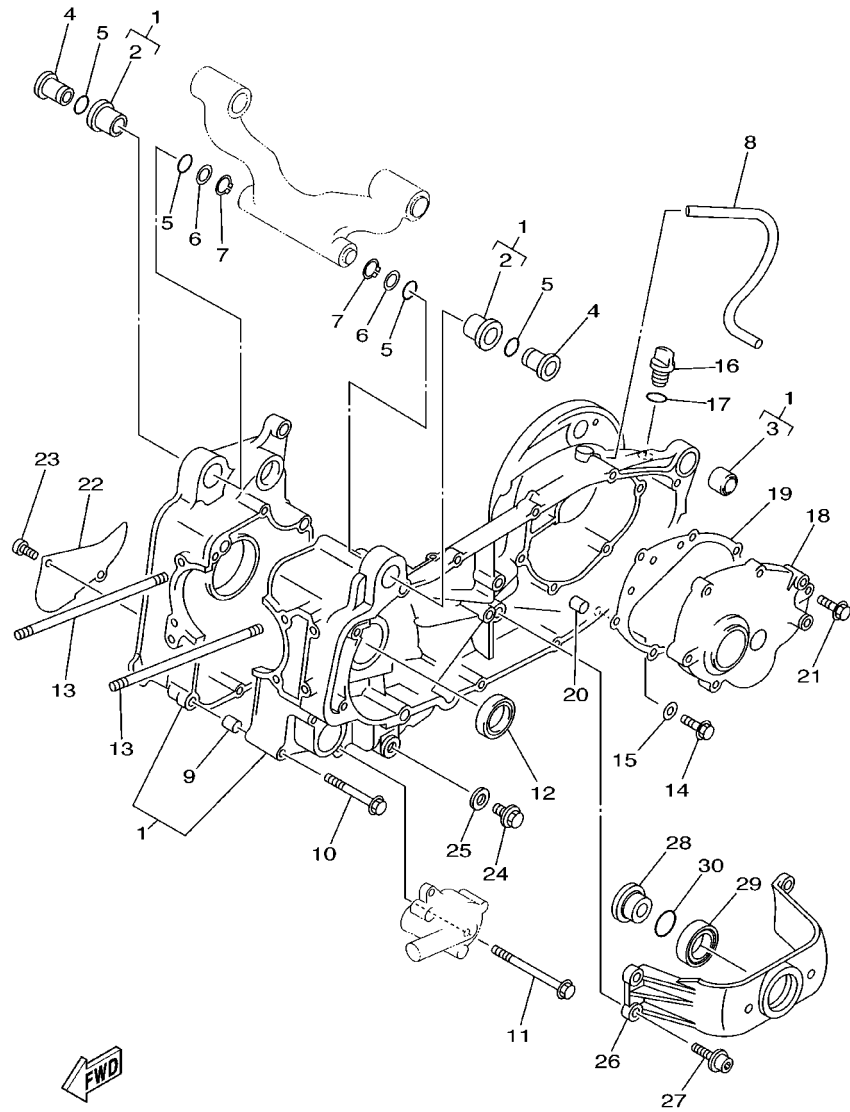

5GM1010-0111

REF. NO.	PART NO.	DESCRIPTION	5GM9					REMARKS
28	5GM-17649-00	SPACER	1					
29	93306-90603	BEARING	1					
30	93210-27672	O-RING	1					

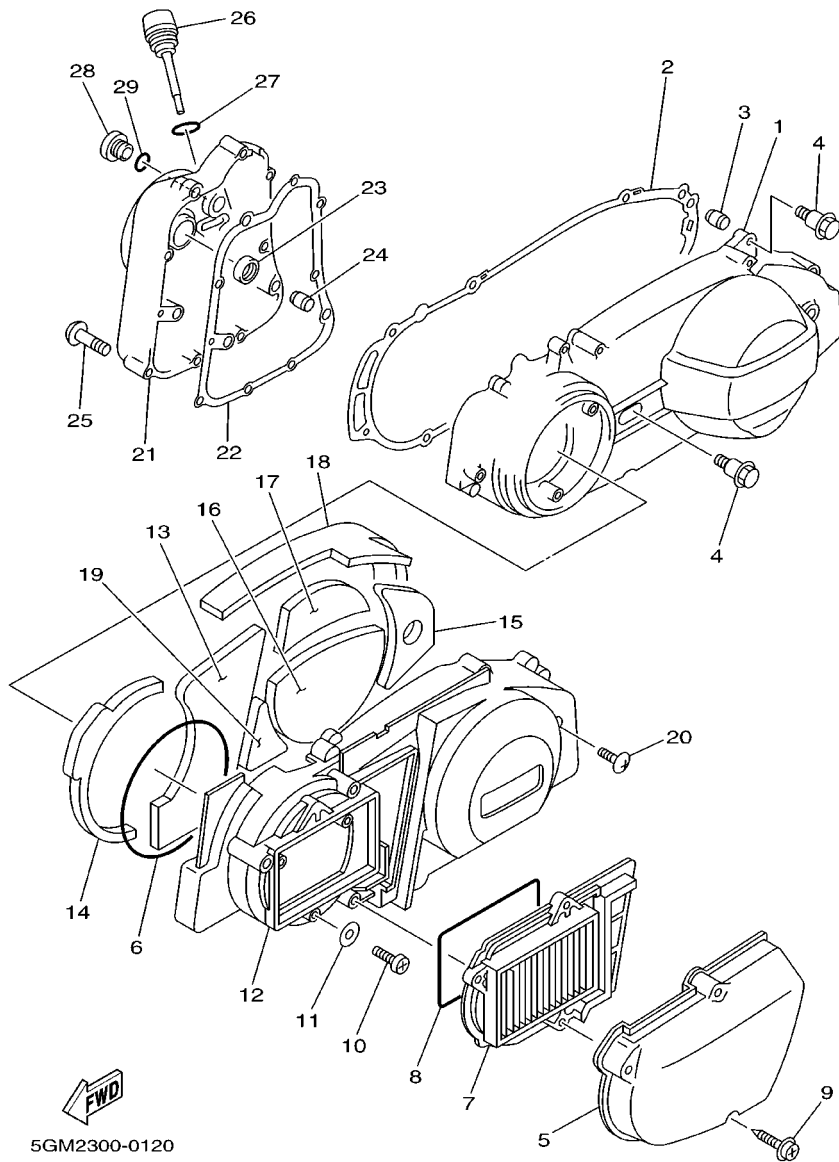
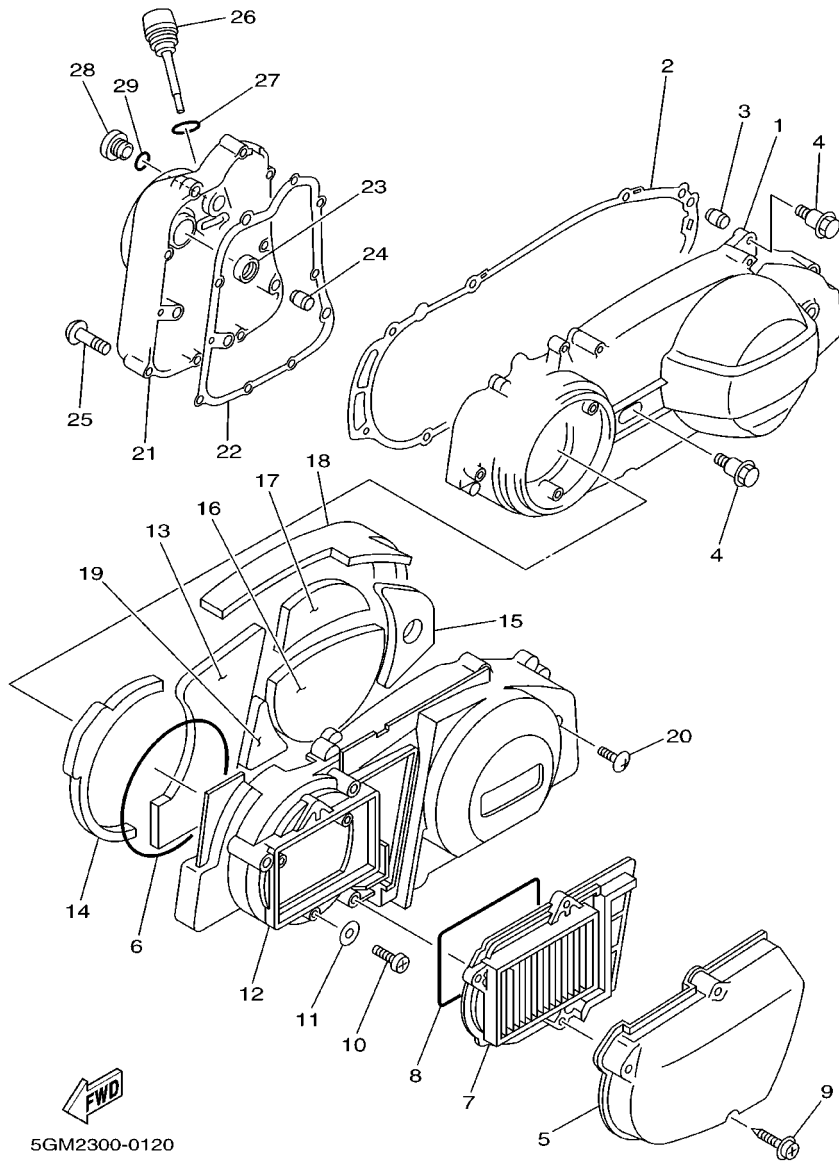

FIG. 12 CRANKCASE COVER 1

REF. NO.	PART NO.	DESCRIPTION	5GM9				REMARKS
1	5GM-15411-00	COVER, CRANKCASE 1	1				
2	5GM-15451-00	GASKET, CRANKCASE COVER 1	1				
3	99530-10114	PIN, DOWEL	2				
4	90109-06030	BOLT	8				
5	5GM-15471-00	DUCT, AIR	1				
6	4HC-15472-00	SEAL, AIR DUCT	1				
7	5GM-15407-00	ELEMENT 1	1				
8	17W-14462-00	SEAL	1				
9	90167-05003	SCREW, TAPPING	3				
10	98507-06020	SCREW, PAN HEAD	3				
11	92907-06600	WASHER, PLATE	3				
12	5GM-15431-00	COVER, CRANKCASE 3	1				
13	5GM-15316-00	DAMPER, ENGINE MOUNT 1	1				
14	5GM-15326-00	DAMPER, ENGINE MOUNT 2	1				
15	5GM-15335-00	DAMPER 3	1				
16	5GM-15337-00	DAMPER 4	1				
17	5GM-15338-00	DAMPER, ENGINE MOUNT 5	1				
18	5GM-15491-00	PROTECTOR	1				
19	5GM-15499-00	PROTECTOR, COVER	1				
20	3KJ-15481-00	BOLT 1	1				
21	5GM-15417-00	COVER, CAP	1				
22	4HC-15453-00	GASKET, CARBURETOR COVER	1				
23	93101-14092	OIL SEAL (S7-14-25-5.5-1-HS)	1				
24	99530-10114	PIN, DOWEL	2				
25	95027-06040	BOLT, FLANGE	10				
26	4HC-15363-00	PLUG, OIL	1				
27	93210-19123	O-RING	1				

FIG. 12 CRANKCASE COVER 1



REF. NO.	PART NO.	DESCRIPTION	5GM9				REMARKS
28	36Y-15189-00	PLUG	1				
29	93210-16325	O-RING	1				

FIG. 13 STARTER

REF. NO.	PART NO.	DESCRIPTION	5GM9				REMARKS
1	4HC-15512-00	GEAR, IDLER 1	1				
2	2HT-15521-00	SHAFT 1	1				
3	90201-12166	WASHER, PLATE	1				
4	99009-12400	CIRCLIP	1				
5	4HC-15517-00	GEAR, IDLER 2	1				
6	4HC-15590-00	STARTER ONE-WAY ASSY	1				
7	91317-08016	BOLT	3				

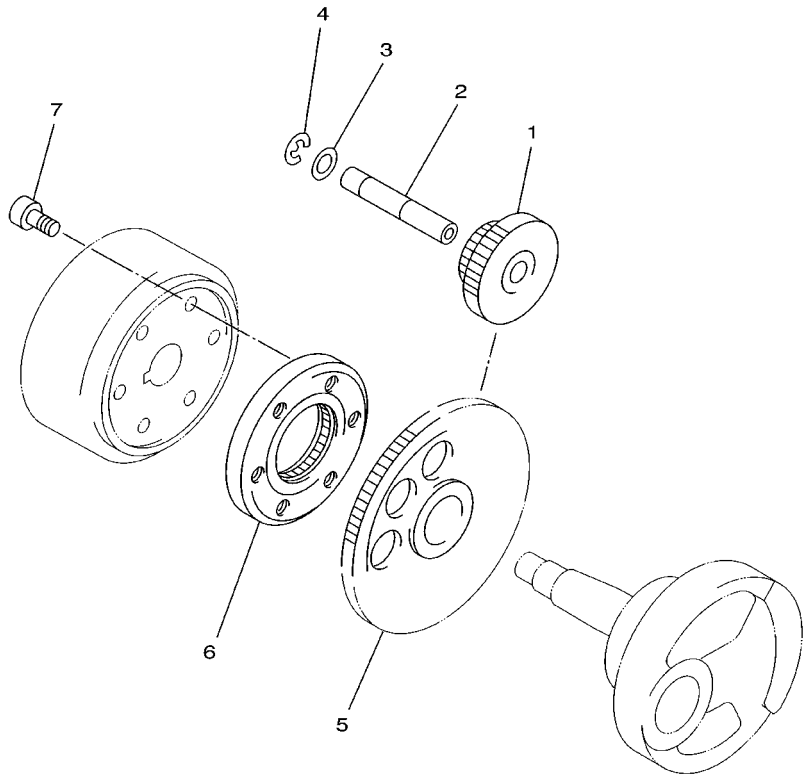

4HC1010-5130

FIG. 14 CLUTCH

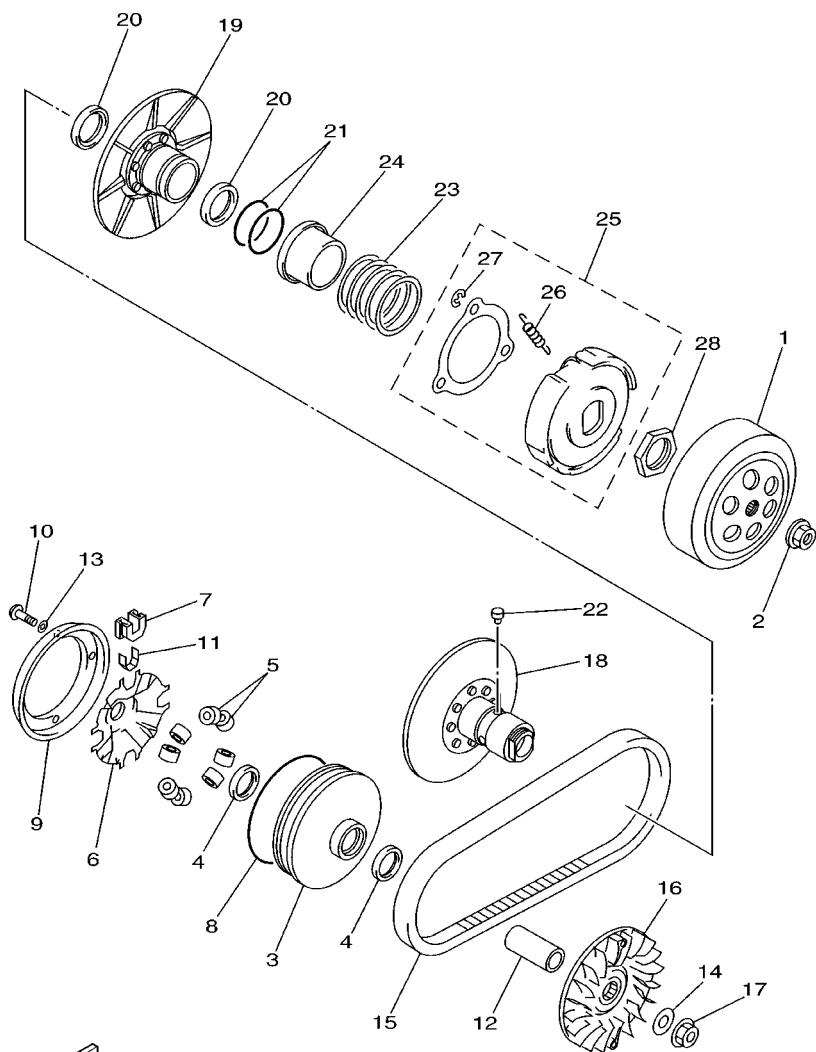

5GM1010-0140

REF. NO.	PART NO.	DESCRIPTION	5GM9	REMARKS
1	5GM-16611-00	CLUTCH HOUSING COMP.	1	
2	90179-14469	NUT	1	
3	5GM-17620-00	PRIMARY SLIDING SHEAVE COMP.	1	
4	93101-28139	OIL SEAL	2	
5	4CW-17632-01	WEIGHT	8	
6	4HC-17623-00	CAM	1	
7	4HC-17653-00	SLIDER	4	
8	93211-17733	O-RING	1	
9	5CG-17639-00	STOPPER	1	
10	90157-04088	SCREW, PAN HEAD	4	
11	4HC-17654-00	SPACER 1	4	
12	90387-1906E	COLLAR	1	
13	90201-047R9	WASHER, PLATE	4	
14	90201-144M8	WASHER, PLATE	1	
15	5CG-17641-00	V-BELT	1	
16	4HC-17611-00	SHEAVE, PRIMARY FIXED	1	
17	90179-14469	NUT	1	
18	5GM-17660-00	SECONDARY FIXED SHEAVE COMP.	1	
19	4HC-17670-10	SECONDARY SLIDING SHEAVE	1	
20	93104-41119	OIL SEAL	2	
21	93210-43713	O-RING	2	
22	4CW-17664-00	PIN, GUIDE	4	
23	90501-505J6	SPRING, COMPRESSION	1	
24	5GM-17644-00	SEAT, SPRING	1	
25	5GM-16620-00	CLUTCH CARRIER ASSY	1	
26	5KD-16626-10	SPRING, CLUTCH WEIGHT 1	3	
27	99001-08600	CIRCLIP	3	

FIG. 14 CLUTCH

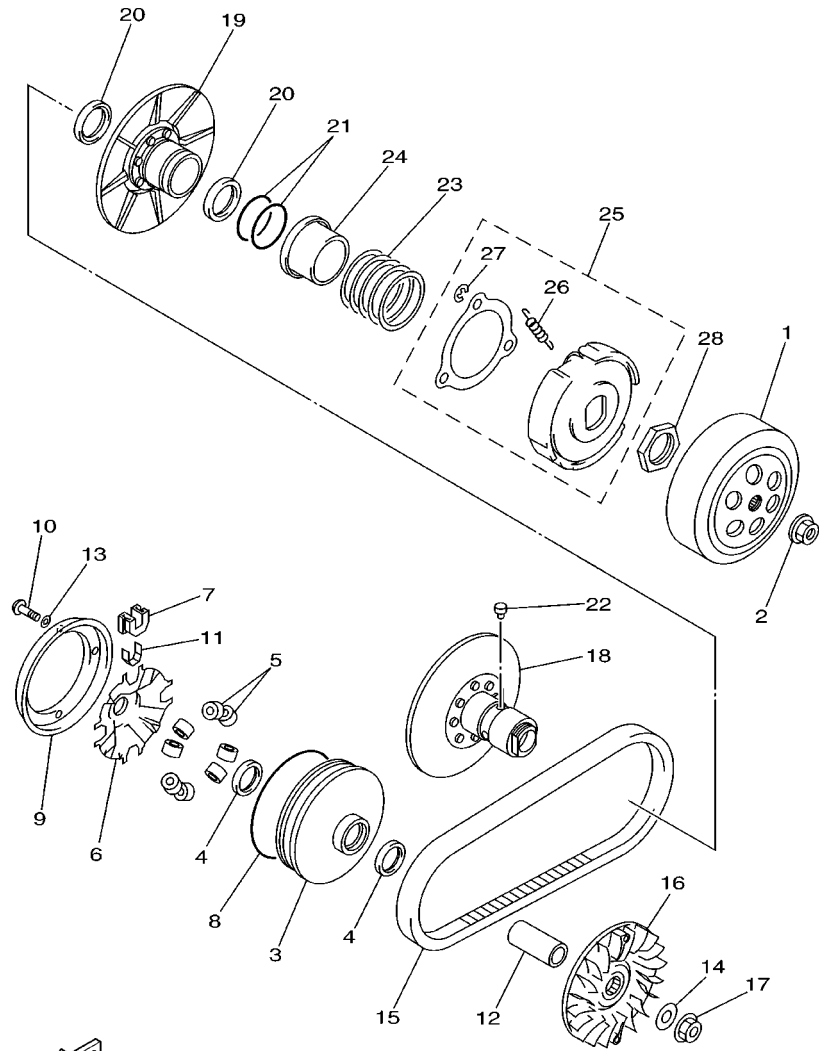

REF. NO.	PART NO.	DESCRIPTION	5GM9				REMARKS
28	90170-36279	NUT	1				

FWD
5GM1010-0140

FIG. 15 TRANSMISSION

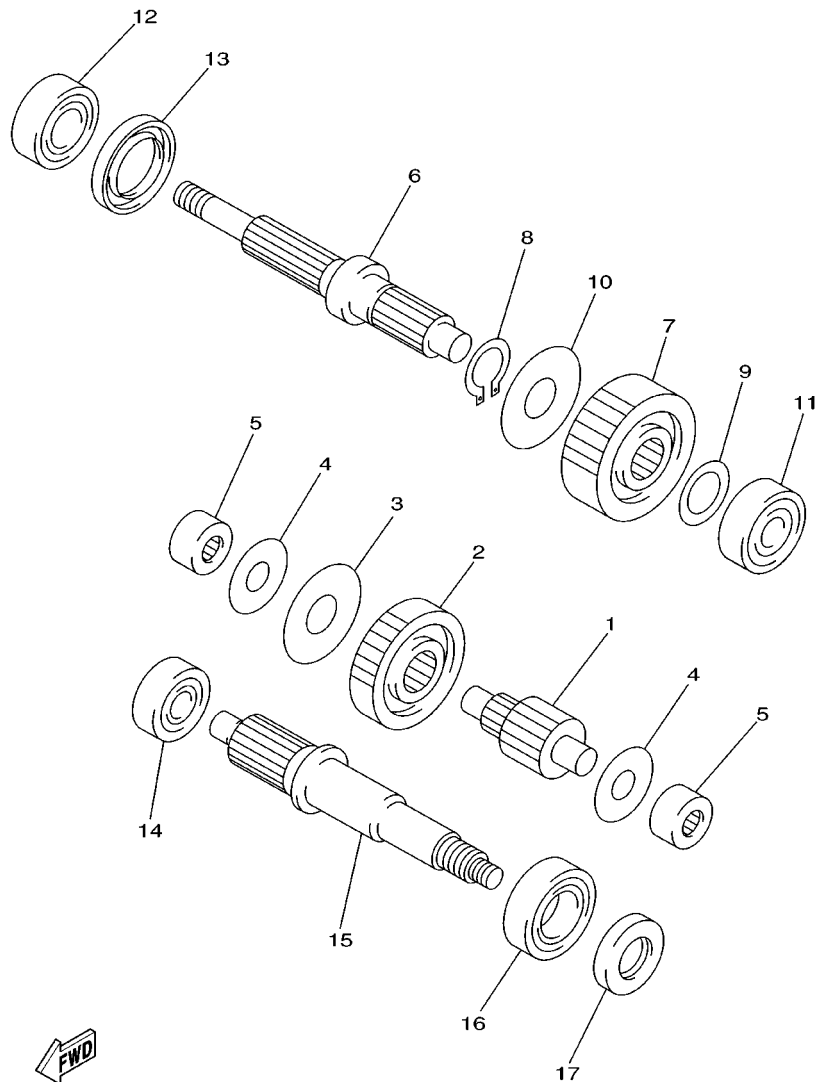

REF. NO.	PART NO.	DESCRIPTION	5GM9				REMARKS
1	5GM-17411-00	AXLE, MAIN	1				
2	5GM-16151-00	GEAR, PRIMARY DRIVEN	1				
3	90208-21001	WASHER, CONICAL SPRING	1				
4	90201-156R4	WASHER, PLATE	2				
5	93311-41566	BEARING	2				
6	5GM-17421-00	AXLE, DRIVE	1				
7	5GM-17211-00	GEAR, 1ST WHEEL (34T)	1				
8	99009-25400	CIRCLIP	1				
9	90201-232K5	WASHER, PLATE	1				
10	90208-25001	WASHER, CONICAL SPRING	1				
11	93306-30321	BEARING	1				
12	93306-27205	BEARING	1				
13	93102-32298	OIL SEAL	1				
14	93306-30201	BEARING (B6302)	1				
15	5GM-16111-00	GEAR, PRIMARY DRIVE	1				
16	93306-20570	BEARING	1				
17	93102-25299	OIL SEAL	1				



5GM1010-0150

FIG. 16 FRAME

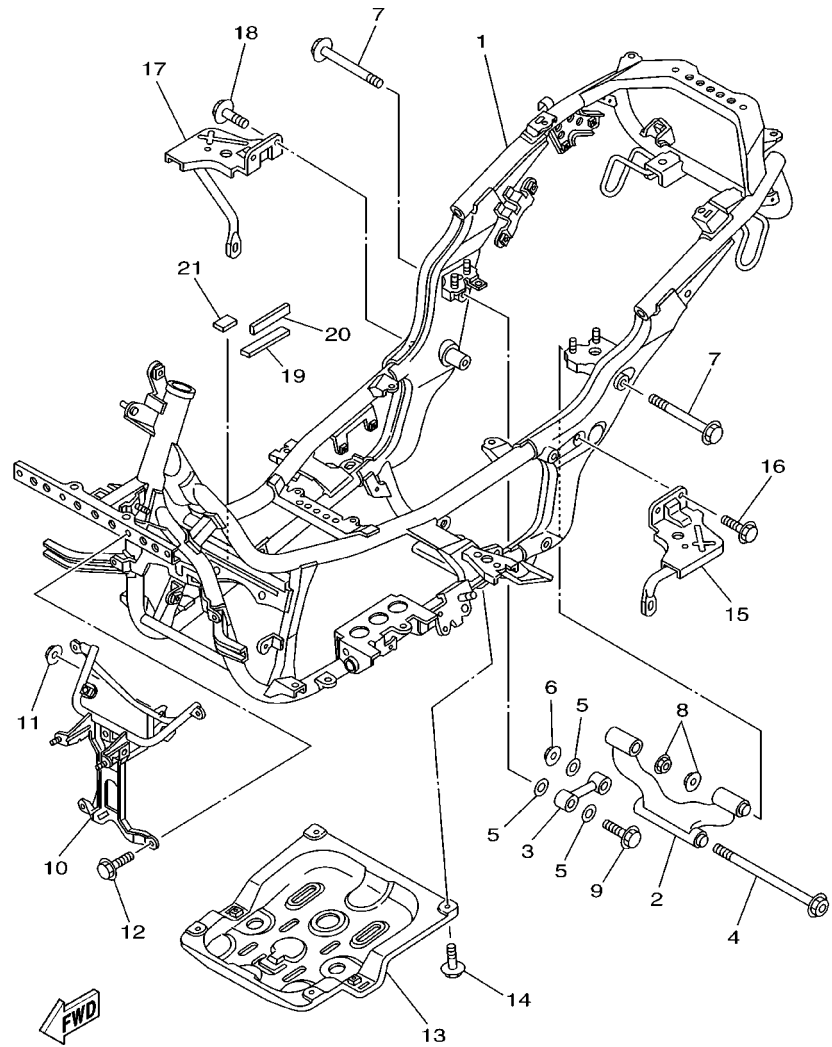

5GM1010-0160

REF. NO.	PART NO.	DESCRIPTION	5GM9				REMARKS
1	5GM-21110-01	FRAME COMP.	1				
2	5CG-21420-01	ENGINE BRACKET COMP. 2	1				
3	4HC-21480-00	STAY, ENGINE	1				
4	90105-10023	BOLT, WASHER BASED	1				
5	90201-105A2	WASHER, PLATE	3				
6	90185-10154	NUT, SELF-LOCKING	1				
7	95817-12120	BOLT, FLANGE	2				
8	90185-12072	NUT, SELF-LOCKING	2				
9	95817-10045	BOLT, FLANGE	1				
10	5GM-28356-A0	STAY 1	1				
11	95707-08500	NUT, FLANGE	1				
12	95807-08016	BOLT, FLANGE	2				
13	5GM-21417-00	BRACKET, FRONT LOWER 1	1				
14	95807-08016	BOLT, FLANGE	2				
15	5GM-27452-00	BRACKET, FOOTREST 1	1				
16	95807-06012	BOLT, FLANGE	3				
17	5GM-27462-00	BRACKET, FOOTREST 2	1				
18	95807-06012	BOLT, FLANGE	3				
19	5GM-27415-00	PLATE, FOOTREST	1				
20	5GM-27424-00	DAMPER, FOOTREST 2	1				
21	5GM-27445-00	PLATE 1	1				

FIG. 17 FENDER

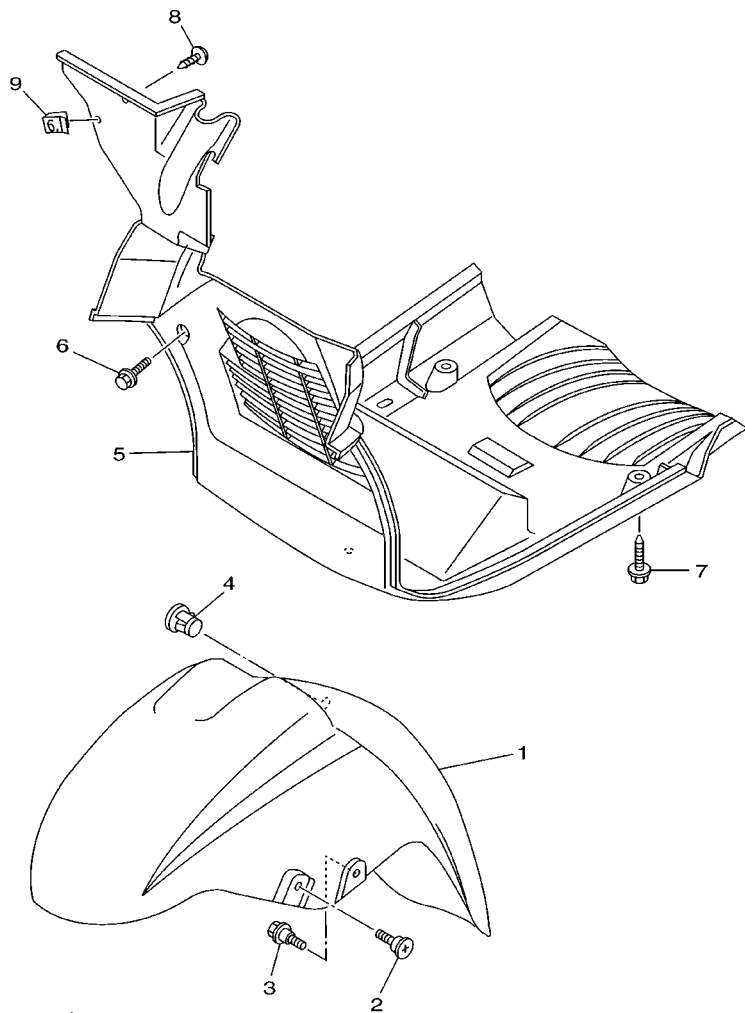

FWD
5GM1010-0170

REF. NO.	PART NO.	DESCRIPTION	5GM9				REMARKS
1	4HC-21511-01-0L	FENDER, FRONT	1				UR MAS
	4HC-21511-01-P5	FENDER, FRONT	1				UR VDBC4
	4HC-21511-01-JY	FENDER, FRONT	1				UR MYM
	4HC-21511-01-PE	FENDER, FRONT	1				UR VDBMA
2	90154-06014	SCREW, BINDING	2				
3	90109-060F3	BOLT	2				
4	5CG-21279-00	PLUG, BLIND	1				
5	5GM-21552-00	FENDER, INNER	1				
6	90119-06044	BOLT, WITH WASHER	2				
7	90119-06060	BOLT, WITH WASHER	2				
8	97707-50016	SCREW, TAPPING	1				
9	90183-05042	NUT, SPRING	1				

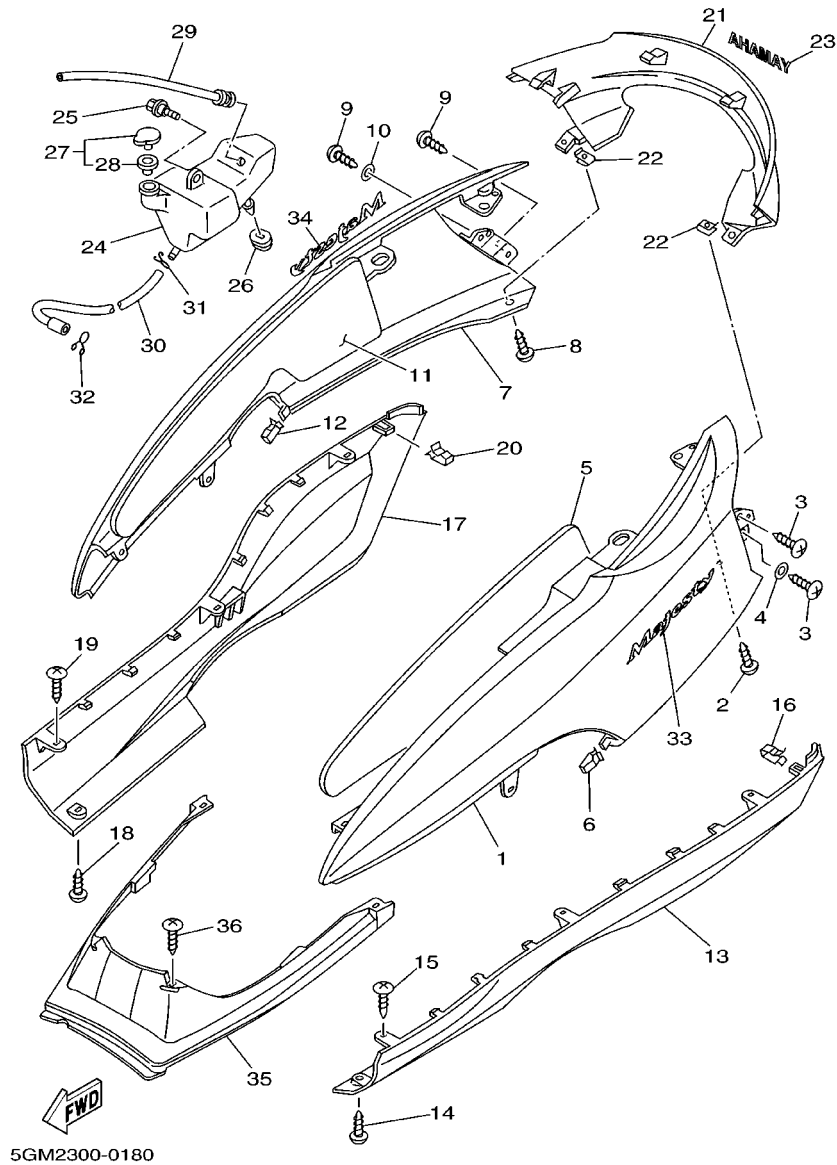

5GM2300-0180

FIG. 18 SIDE COVER

REF. NO.	PART NO.	DESCRIPTION	5GM9			REMARKS
1	5GM-21711-01-0L	COVER, SIDE 1	1			UR MAS
	5GM-21711-01-P0	COVER, SIDE 1	1			UR VDBC4
	5GM-21711-01-JY	COVER, SIDE 1	1			UR MYM
	5GM-21711-01-P5	COVER, SIDE 1	1			UR VDBMA
2	90167-05079	SCREW, TAPPING	2			
3	97707-50012	SCREW, TAPPING	4			
4	90201-05725	WASHER, PLATE	1			
5	5GM-21778-00	DAMPER, LOCATING 1	1			
6	5GM-28379-00	HOOK	1			
7	5GM-21721-01-0L	COVER, SIDE 2	1			UR MAS
	5GM-21721-01-P0	COVER, SIDE 2	1			UR VDBC4
	5GM-21721-01-JY	COVER, SIDE 2	1			UR MYM
	5GM-21721-01-P5	COVER, SIDE 2	1			UR VDBMA
8	90167-05079	SCREW, TAPPING	2			
9	97707-50012	SCREW, TAPPING	4			
10	90201-05725	WASHER, PLATE	1			
11	5GM-21779-00	DAMPER, LOCATING 2	1			
12	5GM-28379-00	HOOK	1			
13	5GM-2171L-00-0L	MOLE, SIDE COVER 1	1			UR MAS
	5GM-2171L-00-P0	MOLE, SIDE COVER 1	1			UR VDBC4
	5GM-2171L-00-JY	MOLE, SIDE COVER 1	1			UR MYM
	5GM-2171L-00-P5	MOLE, SIDE COVER 1	1			UR VDBMA
14	97707-50016	SCREW, TAPPING	1			
15	97707-50012	SCREW, TAPPING	3			
16	5GM-28379-00	HOOK	1			
17	5GM-2171M-00-0L	MOLE, SIDE COVER 2	1			UR MAS
	5GM-2171M-00-P0	MOLE, SIDE COVER 2	1			UR VDBC4

FIG. 18 SIDE COVER

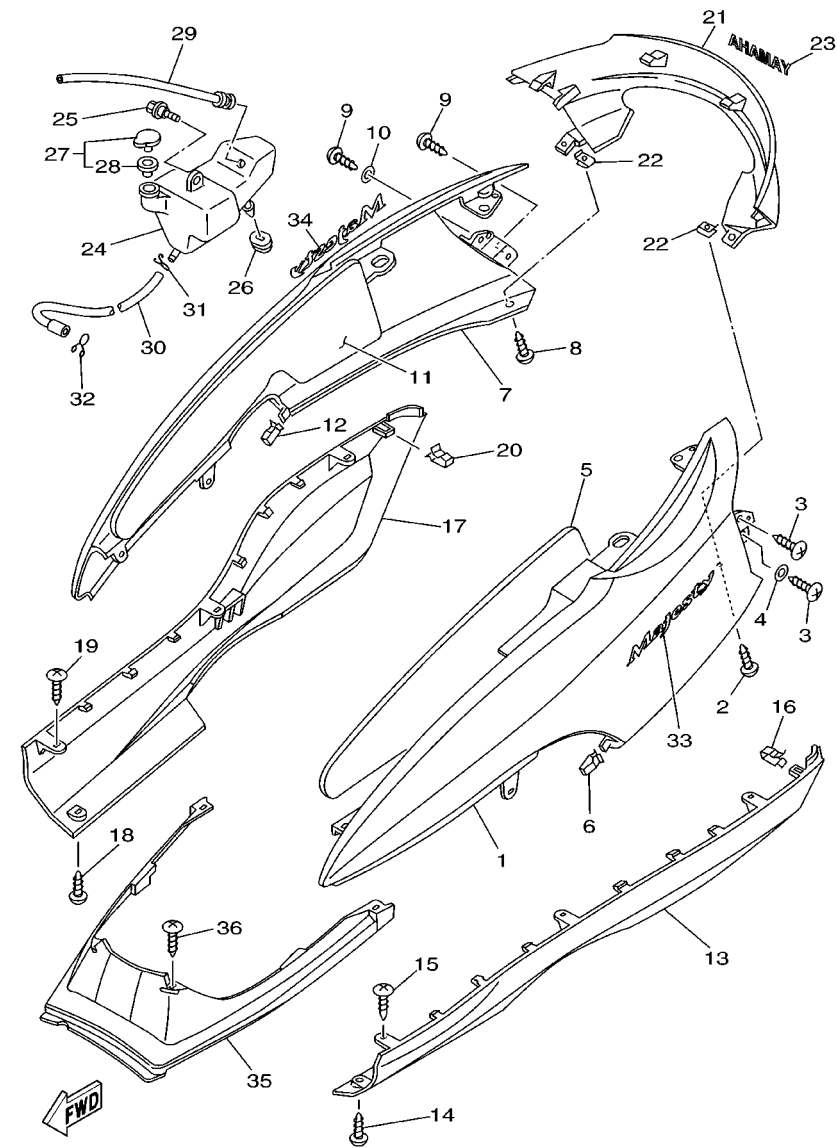

5GM2300-0180

REF. NO.	PART NO.	DESCRIPTION	5GM9	REMARKS
17	5GM-2171M-00-JY	MOLE, SIDE COVER 2	1	UR MYM
	5GM-2171M-00-P5	MOLE, SIDE COVER 2	1	UR VDBMA
18	97707-50016	SCREW, TAPPING	1	
19	97707-50012	SCREW, TAPPING	3	
20	5GM-28379-00	HOOK	1	
21	5GM-2171N-00-0L	MOLE, SIDE COVER 3	1	UR MAS
	5GM-2171N-00-P0	MOLE, SIDE COVER 3	1	UR VDBC4
	5GM-2171N-00-JY	MOLE, SIDE COVER 3	1	UR MYM
	5GM-2171N-00-P5	MOLE, SIDE COVER 3	1	UR VDBMA
22	90183-05042	NUT, SPRING	2	
23	99247-00080	EMBLEM, YAMAHA	1	UR FOR MAS
	99246-00080	EMBLEM, YAMAHA	1	UR FOR VDBC4,MYM, VDBMA
24	5GM-21871-00	TANK, RECOVERY	1	
25	90109-063F1	BOLT	1	
26	90480-01288	GROMMET	1	
27	1AA-21815-00	CAP	1	
28	1AA-21874-00	.GASKET	1	
29	5GM-21816-00	PIPE 1	1	
30	5GM-21817-00	PIPE 2	1	
31	90467-08003	CLIP	1	
32	90467-10008	CLIP	1	
33	5GM-2173B-00	EMBLEM	1	
34	5GM-2173B-00	EMBLEM	1	
35	5GM-21731-00	COVER, SIDE 3	1	
36	97707-50016	SCREW, TAPPING	4	

FIG. 19 REAR ARM. SUSPENSION

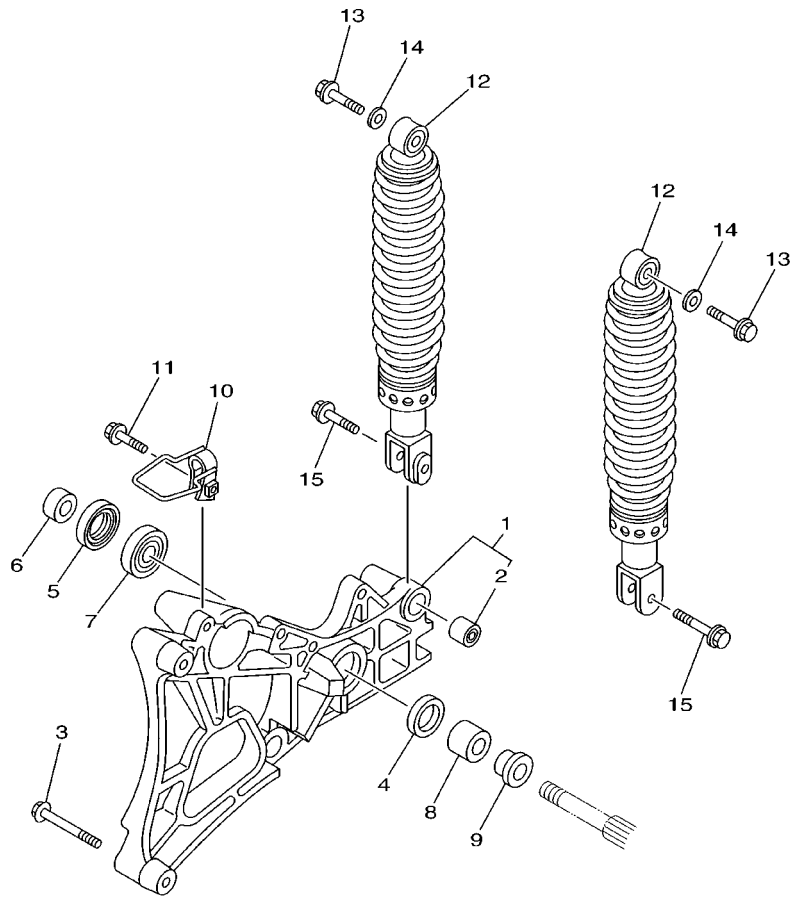

REF. NO.	PART NO.	DESCRIPTION	5GM9				REMARKS
1	5GM-22100-00	REAR ARM ASSY	1				
2	164-22216-00	.BUSH, REAR SHOCK ABSORBER	1				
3	95817-08070	BOLT, FLANGE	2				
4	93109-28043	OIL SEAL	1				
5	93106-26005	OIL SEAL	1				
6	90387-15423	COLLAR	1				
7	93306-30212	BEARING	1				
8	90387-154E1	COLLAR	1				
9	90387-155F2	COLLAR	1				
10	5GM-25875-00	HOLDER, BRAKE HOSE 1	1				
11	95807-06025	BOLT, FLANGE	1				
12	5GM-22210-00	SHOCK ABSORBER ASSY, REAR	2				
13	95827-10035	BOLT, FLANGE	2				
14	90201-105A2	WASHER, PLATE	2				
15	95827-08030	BOLT, FLANGE	2				

5GM1010-0190

FIG. 20 STEERING

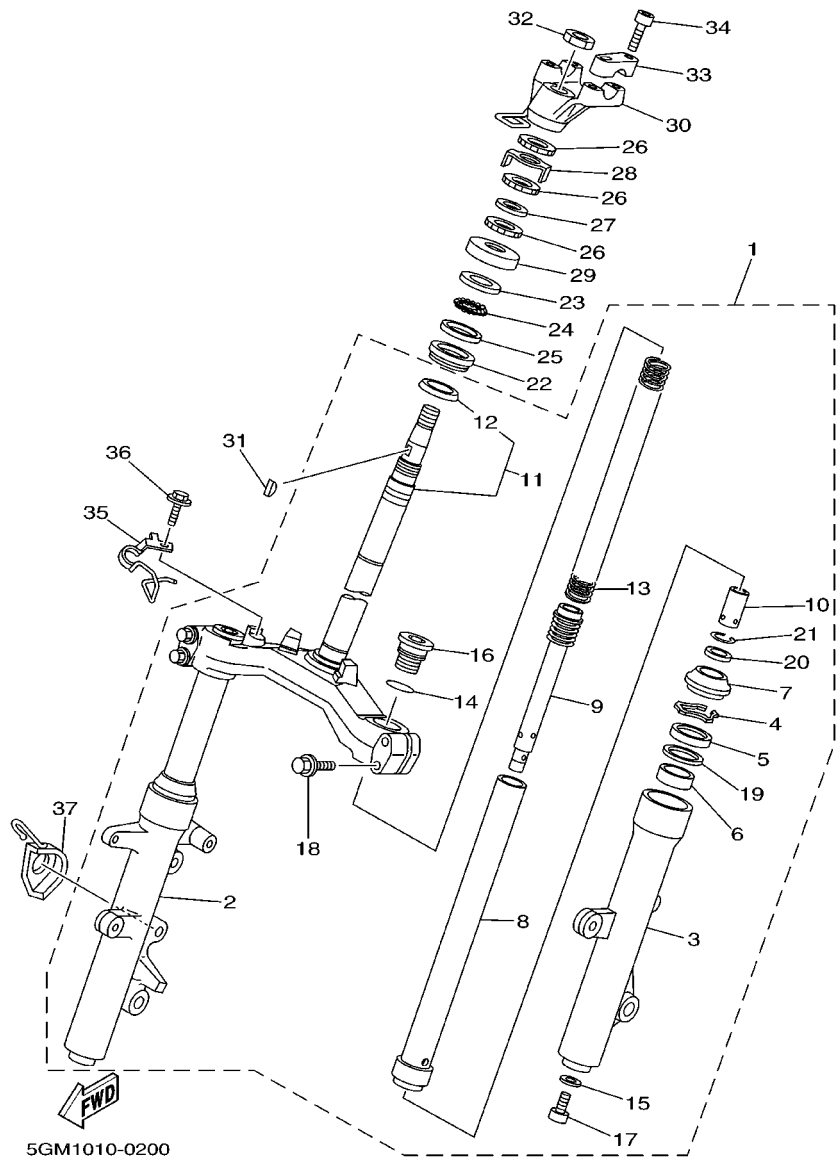

5GM1010-0200

REF. NO.	PART NO.	DESCRIPTION	5GM9				REMARKS
1	5GM-23100-00	FRONT FORK ASSY	1				
2	4HC-23136-10	.TUBE, OUTER (RIGHT)	1				
3	4HC-23126-10	.TUBE, OUTER (LEFT)	1				
4	22W-23153-L0	.RING, SNAP	2				
5	2UJ-23145-00	.OIL SEAL	2				
6	4HC-23125-20	.METAL, SLIDE 1	2				
7	2UJ-23144-00	.SEAL, DUST	2				
8	5GM-23110-00	.INNER TUBE COMP.1	2				
9	5GM-23170-00	.CYLINDER COMP., FRONT FORK	2				
10	4HC-23173-20	.SPINDLE, TAPER	2				
11	5GM-23340-00	.UNDER BRACKET COMP.	1				
12	164-23462-00	..SEAL, STEERING	1				
13	5GM-23141-00	.SPRING, FRONT FORK	2				
14	3J2-23114-00	.O-RING	2				
15	509-23158-L0	.GASKET	2				
16	4HC-23111-00	.BOLT, CAP	2				
17	278-23181-50	.BOLT, HEXAGON SOCKET HEAD	2				
18	95027-08040	.BOLT, FLANGE	4				
19	22W-23146-L0	.WASHER, OIL SEAL	2				
20	4HC-23184-10	.CAP, AIR VALVE	2				
21	3G2-23183-00	.RING, SNAP	2				
22	93399-99942	BEARING	1				
23	22F-23411-01	RACE, BALL 1	1				
24	22F-2341E-00	RETAINER, BALL BEARING	1				
25	22F-23412-01	RACE, BALL 2	1				
26	90179-25615	NUT	3				
27	90202-26142	WASHER, PLATE	1				

FIG. 20 STEERING

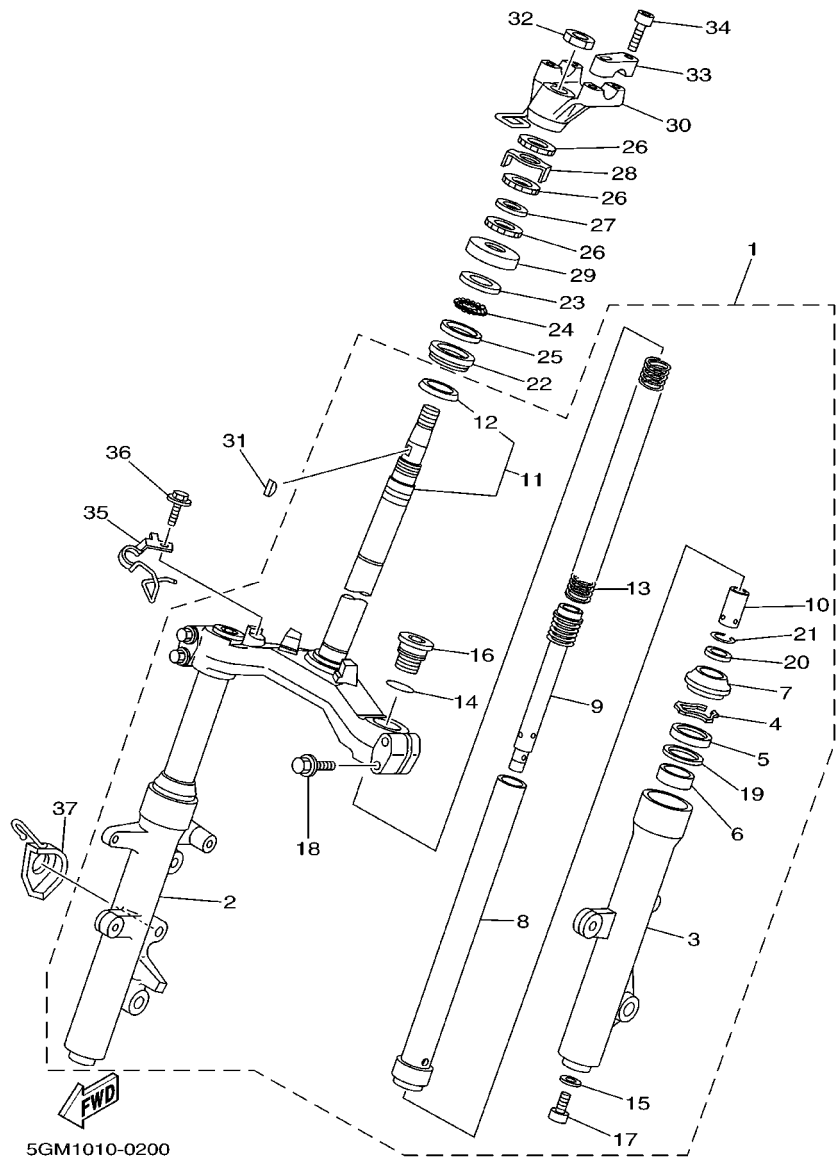

REF. NO.	PART NO.	DESCRIPTION	5GM9	REMARKS
28	3YF-23418-00	WASHER, SPECIAL	1	
29	3VP-23416-00	COVER, BALL RACE 2	1	
30	4HC-23442-11	HOLDER, HANDLE LOWER	1	
31	90280-03017	KEY, WOODRUFF	1	
32	90170-20386	NUT	1	
33	4H7-23441-00-98	HOLDER, HANDLE UPPER	2	LGB
34	91317-08030	BOLT	4	
35	4HC-25875-01	HOLDER, BRAKE HOSE 1	1	
36	95807-06012	BOLT, FLANGE	1	
37	5CG-23317-00	HOLDER, CABLE	1	

FIG. 21 FUEL TANK

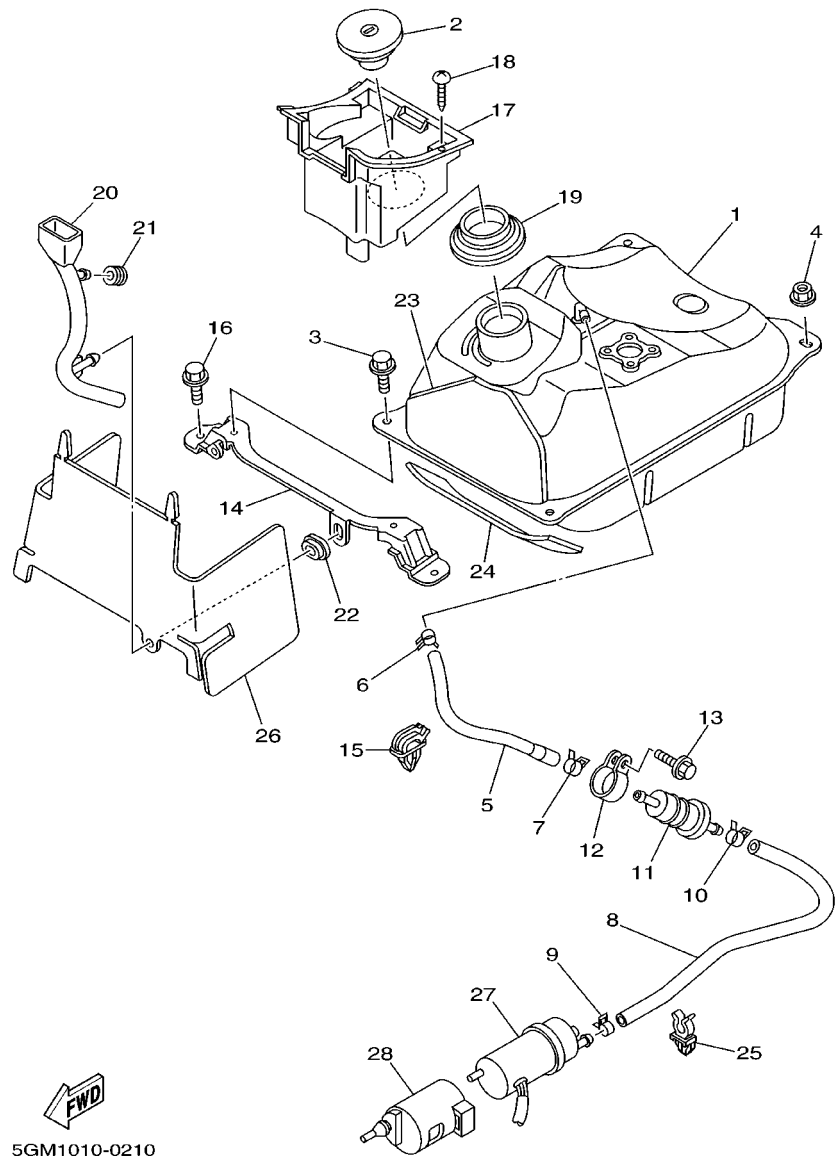

5GM1010-0210

REF. NO.	PART NO.	DESCRIPTION	5GM9				REMARKS
1	5GM-24110-10	FUEL TANK COMP.	1				
2	3KJ-24602-03	CAP ASSY	1				
3	95827-06012	BOLT, FLANGE	2				
4	95707-06500	NUT, FLANGE	2				
5	5GM-24311-00	PIPE, FUEL 1	1				
6	90467-10038	CLIP	1				
7	90467-12053	CLIP	1				
8	5GM-24312-00	PIPE 2	1				
9	90467-10038	CLIP	1				
10	90467-12053	CLIP	1				
11	1FK-24560-00	FILTER ASSY	1				
12	1AE-24366-00	CLAMP, FUEL PIPE 1	1				
13	95027-06012	BOLT, FLANGE	1				
14	5GM-24191-00	BRACKET, FUEL TANK 1	1				
15	90464-07001	CLAMP	1				
16	95827-06012	BOLT, FLANGE	2				
17	5GM-2414A-00	COVER, FILLER	1				
18	97707-50012	SCREW, TAPPING	2				
19	5GM-2414G-00	SEAL	1				
20	5GM-24667-00	GUIDE, PIPE	1				
21	90480-12237	GROMMET	1				
22	90480-01558	GROMMET	1				
23	5GM-24145-00	DAMPER, SIDE COVER	1				
24	5GM-24145-10	DAMPER, SIDE COVER	1				
25	90464-09008	CLAMP	2				
26	5GM-2414H-00	DAMPÉR, PLATE 1	1				
27	2GV-13907-00	FUEL PUMP COMP.	1				

FIG. 21 FUEL TANK

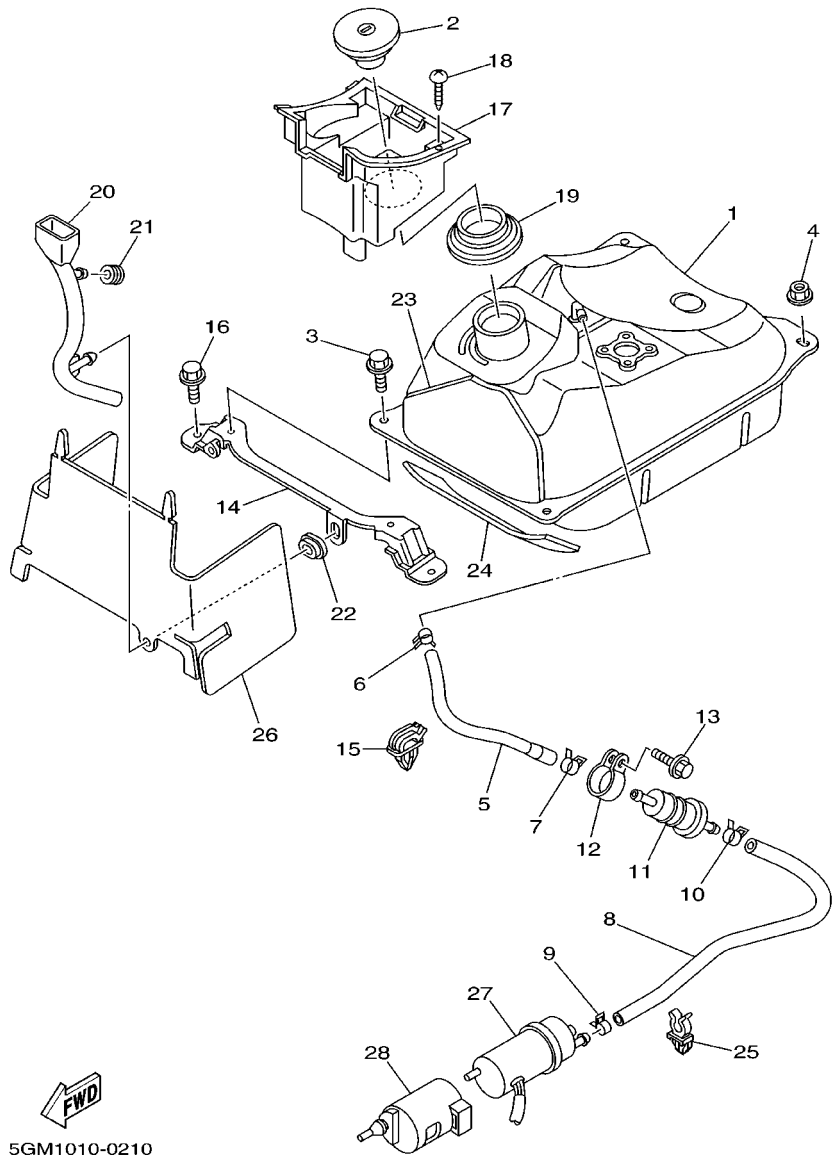

5GM1010-0210

REF. NO.	PART NO.	DESCRIPTION	5GM9				REMARKS
28	5GM-24492-00	BUSH, FULEL PUMP	1				

FIG. 22 SEAT

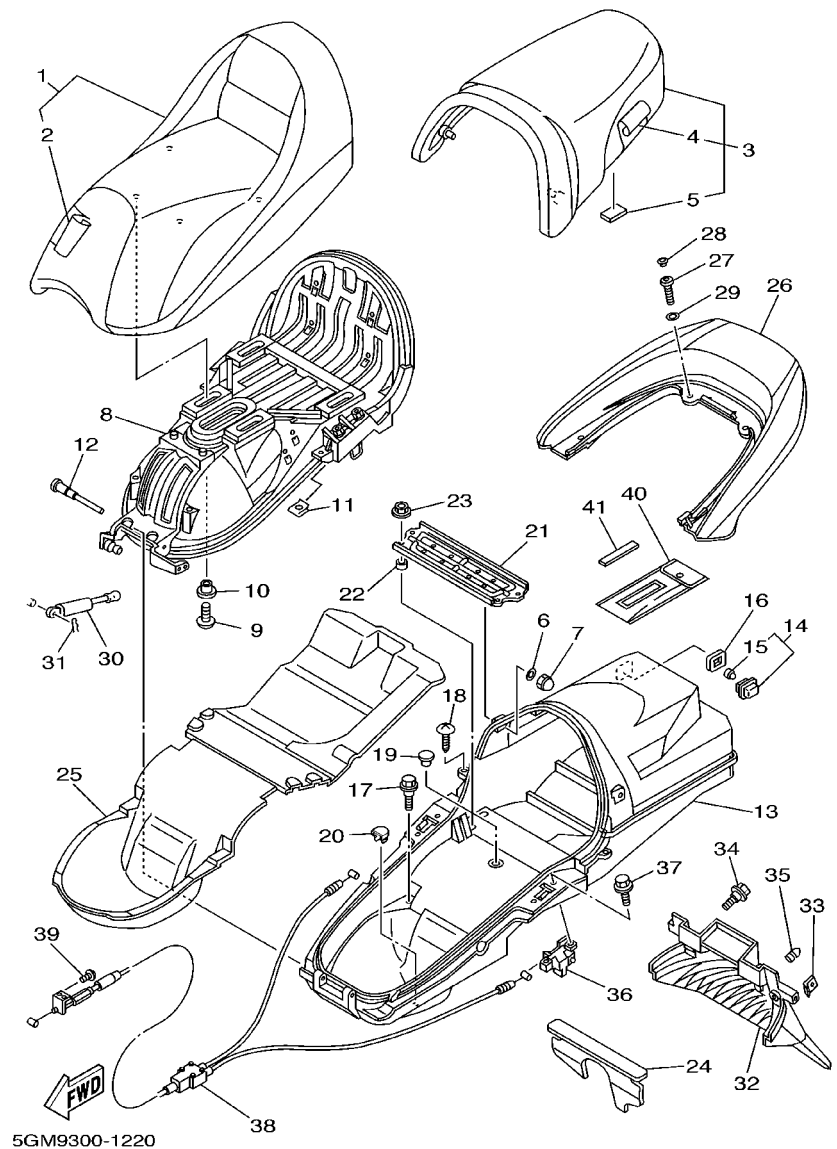

REF. NO.	PART NO.	DESCRIPTION	5GM9	REMARKS
1	5GM-24710-11	SINGLE SEAT ASSY	1	
2	5GM-2470F-21	.COVER, SEAT	1	
3	5GM-24750-00	TANDEM SEAT ASSY	1	
4	5GM-2470F-10	.COVER, SEAT	1	
5	5GM-24747-00	.DAMPER, SEAT	2	
6	90201-06057	WASHER, PLATE	2	
7	90176-06003	NUT, CROWN	2	
8	5GM-2470E-00	BOTTOM PLATE COMP.	1	
9	90110-06202	BOLT, HEXAGON SOCKET HEAD	4	
10	90387-06500	COLLAR	4	
11	90183-05042	NUT, SPRING	2	
12	5GM-24774-00	PIN	1	
13	5GM-24704-00	BOX ASSY	1	
14	4HC-84770-00	LIGHT, ACCESORY	1	
15	4HC-84347-00	.BULB (12V-2W)	1	
16	5GM-2839M-00	SEAL, BOX 2	1	
17	90109-063F1	BOLT	4	
18	97707-50016	SCREW, TAPPING	2	
19	90338-11125	PLUG	1	
20	5GM-2467E-00	CAP	1	
21	5GM-24738-00	BRACKET, SEAT	1	
22	90560-08326	SPACER	4	
23	95707-08500	NUT, FLANGE	1	
24	5GM-2177F-00	COVER	1	
25	5GM-24723-00	DAMPER, SEAT	1	
26	5GM-24773-00-0L	HANDLE, SEAT	1	UR MAS
	5GM-24773-00-P0	HANDLE, SEAT	1	UR VDBC4

FIG. 22 SEAT

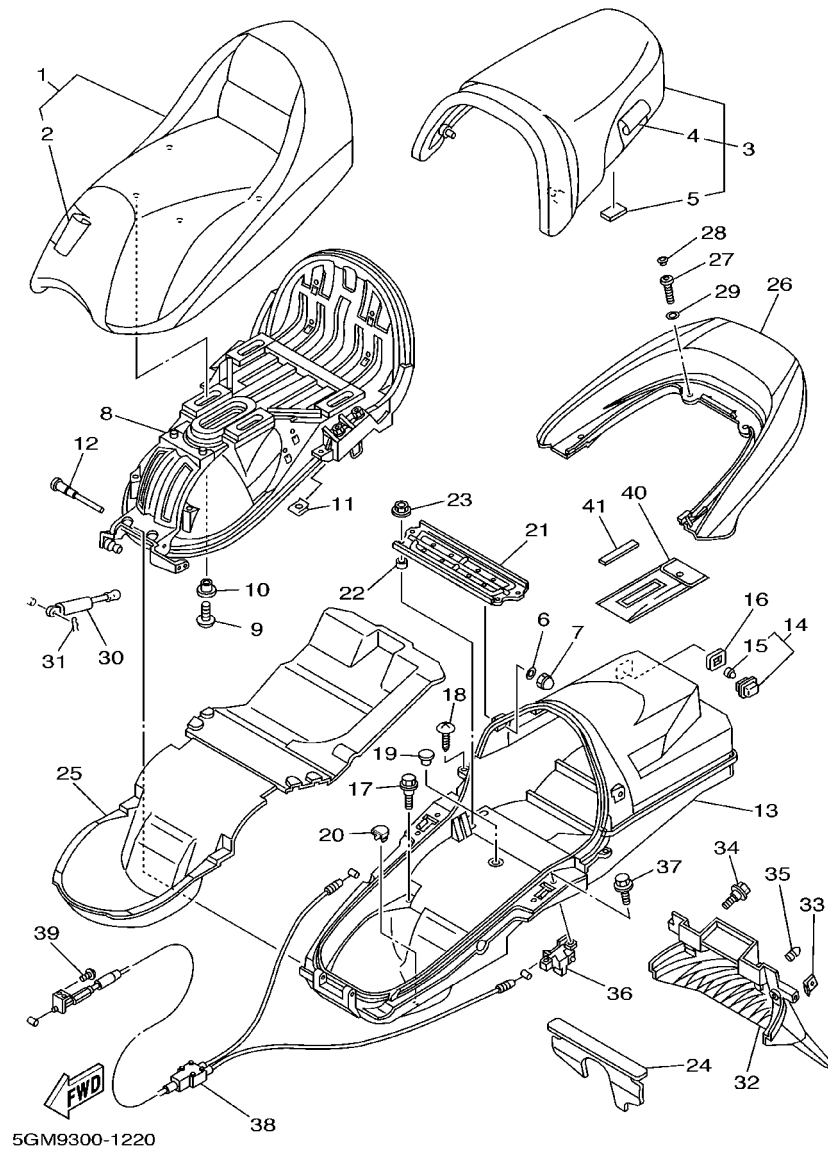

REF. NO.	PART NO.	DESCRIPTION	5GM9				REMARKS
26	5GM-24773-00-JY	HANDLE, SEAT	1				UR MYM
	5GM-24773-00-P5	HANDLE, SEAT	1				UR VDBMA
27	90109-084F7	BOLT	4				
28	341-23469-00	CAP, BOLT	4				
29	90201-08784	WASHER, PLATE	4				
30	5GM-2478G-00	STOPPER	1				
31	90468-18121	CLIP	1				
32	5GM-21629-00	GUARD, MUD	1				
33	90183-05042	NUT, SPRING	2				
34	90109-063F1	BOLT	2				
35	5A8-21639-00	DAMPER 2	1				
36	5GM-24780-00	SEAT LOCK ASSY	2				
37	90109-063F1	BOLT	4				
38	5GM-2478D-01	SEAT LOCK CABLE ASSY	1				
39	98507-05010	SCREW, PAN HEAD	1				
40	5GM-28100-00	TOOL KIT	1				
41	4KG-2814E-10	HOOK	1				

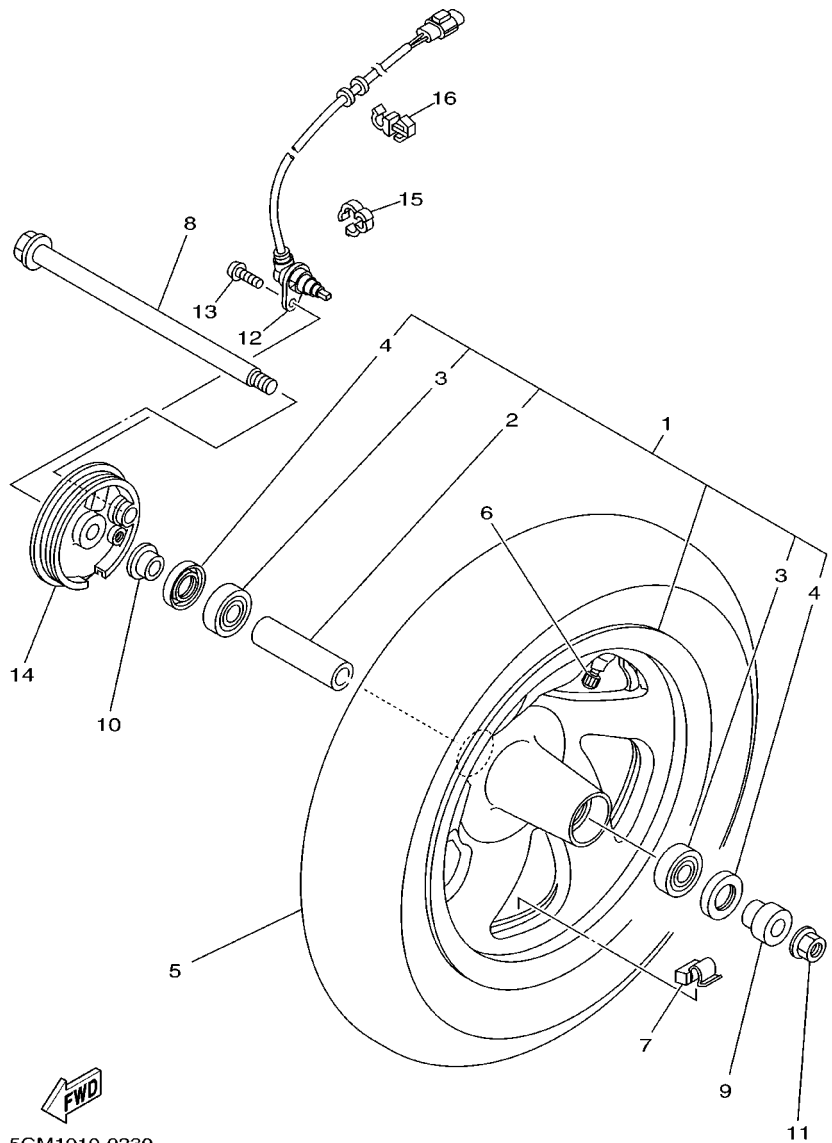

5GM1010-0230

FIG. 23 FRONT WHEEL

REF. NO.	PART NO.	DESCRIPTION	5GM9				REMARKS
1	5CG-25160-A0-35	CAST WHEEL, FRONT	1				SL
2	90387-1508E	.COLLAR	1				
3	93306-30202	.BEARING	2				
4	93102-22014	.OIL SEAL	2				
5	94111-1214N	TIRE (110/90-12 64L MB67/TL)	1				UR INOUE
	94111-1215R	TIRE (110/90-12 64L TL/TT)	1				UR MICHELIN
6	93900-00022	VALVE, RIM	1				TAIHEIYO
7	29L-25398-00	BALANCER, WHEEL (10G)	1				UN
	29L-25398-10	BALANCER, WHEEL (20G)	1				UN
	29L-25398-20	BALANCER, WHEEL (30G)	1				UN
8	4HC-25181-00	AXLE, WHEEL	1				
9	90387-151R0	COLLAR	1				
10	90387-153N7	COLLAR	1				
11	90185-14166	NUT, SELF-LOCKING	1				
12	5GM-85970-00	WHEEL SENSOR ASSY, FRONT	1				
13	92014-08016	BOLT, BUTTON HEAD	1				
14	5CG-2517A-00	HOUSING, SENSOR FRONT	1				
15	90465-14310	CLAMP	3				
16	90464-08051	CLAMP	1				

FIG. 24 FRONT BRAKE CALIPER

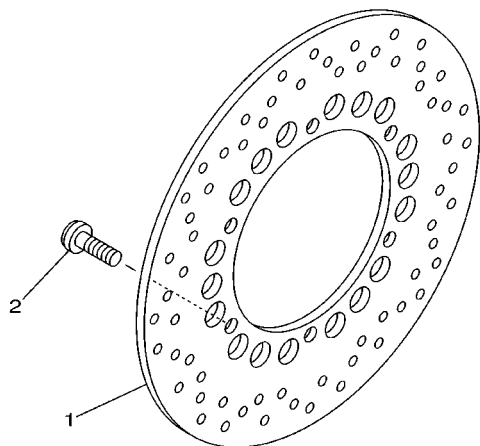
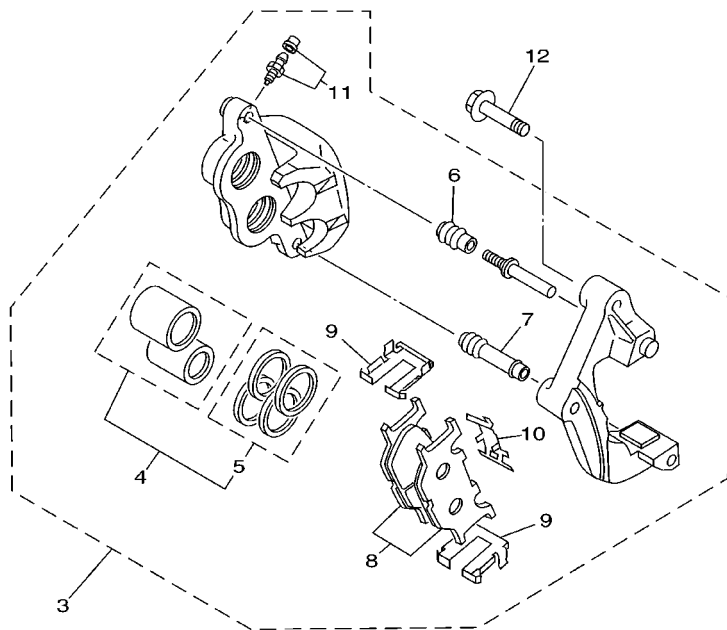

5GM1010-0240

REF. NO.	PART NO.	DESCRIPTION	5GM9					REMARKS
1	4HC-2582T-00	DISC, BRAKE	1					
2	90109-083G4	BOLT	6					
3	5CG-2580U-00	CALIPER ASSY (RIGHT)	1					
4	4FU-W0057-50	.PISTON ASSY, CALIPER	1					
5	4FU-W0047-50	..CALIPER SEAL KIT	1					
6	5R2-25937-00	.BOOT 2	1					
7	3YX-25937-00	.BOOT 2	1					
8	4HM-W0045-00	.BRAKE PAD KIT	1					
9	4BP-25919-00	.SUPPORT, PAD	2					
10	3YX-25929-00	.SPRING, ANTI RATTLE	1					
11	51L-W0048-00	.BLEED SCREW KIT	1					
12	90105-10638	BOLT, WASHER BASED	2					

FIG. 25 REAR WHEEL

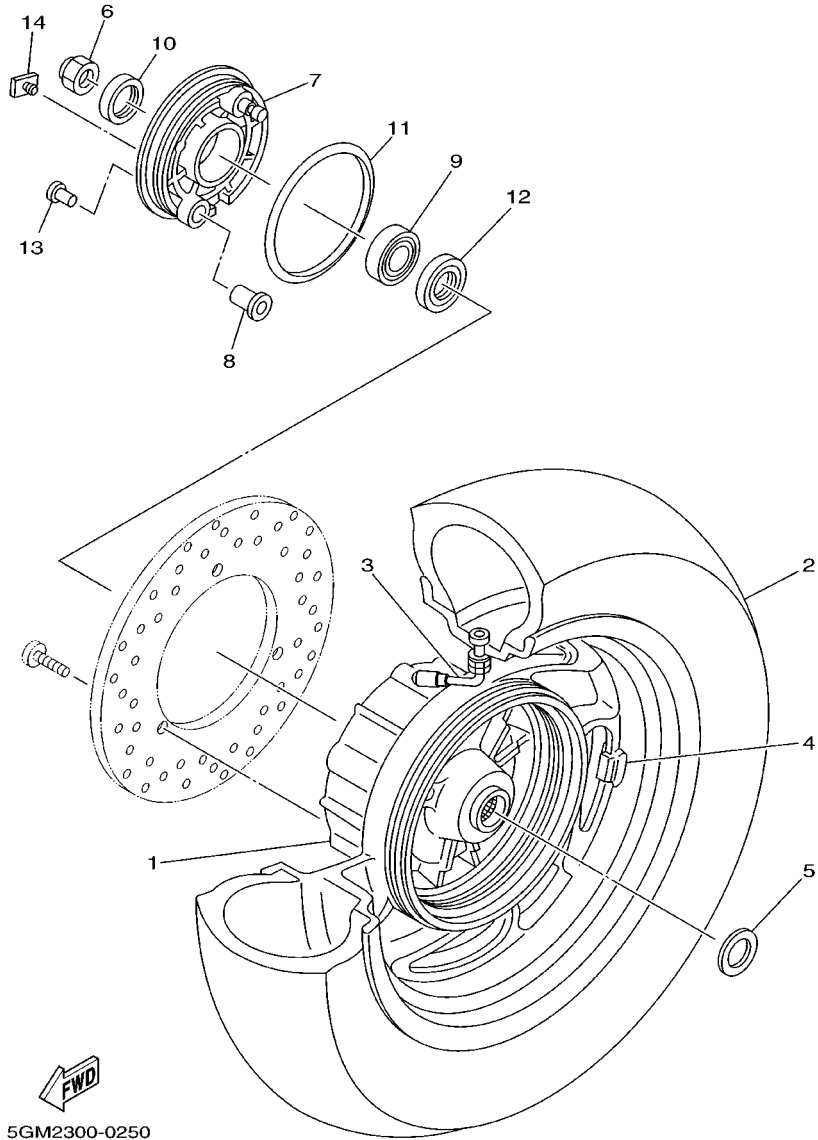

5GM2300-0250

REF. NO.	PART NO.	DESCRIPTION	5GM9				REMARKS
1	5GM-25338-00-35	CAST WHEEL, REAR	1				SL
2	94113-1204P	TIRE (130/70-12 62L MB67/TL)	1				UR INOUE
	94113-1215X	TIRE (130/70-12 62L TL/TT)	1				UR MICHELIN
3	93900-00025	VALVE, RIM	1				
4	29L-25398-00	BALANCER, WHEEL (10G)	1				UN
	29L-25398-10	BALANCER, WHEEL (20G)	1				UN
	29L-25398-20	BALANCER, WHEEL (30G)	1				UN
5	90201-220J8	WASHER, PLATE	1				
6	90185-14163	NUT, SELF-LOCKING	1				
7	5GM-25321-00-35	PLATE, BRAKE SHOE	1				SL
8	5GM-25328-00	BUSH, CAMSHAFT	1				
9	93306-30212	BEARING	1				
10	93109-28043	OIL SEAL	1				
11	5GM-25319-00	SEAL, HUB DUST	1				
12	93102-22014	OIL SEAL	1				
13	90338-10150	PLUG	1				
14	5GM-25683-00	SPACER	1				

FIG. 26 REAR BRAKE CALIPER

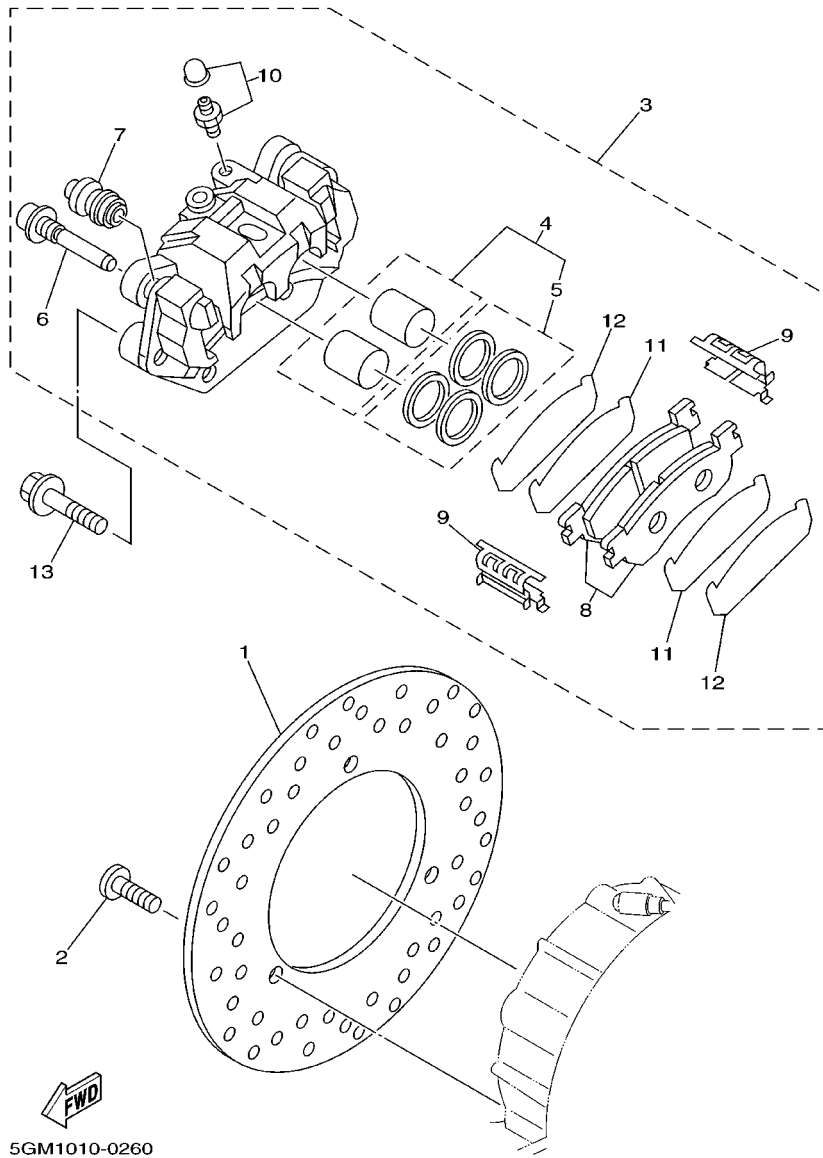

5GM1010-0260

REF. NO.	PART NO.	DESCRIPTION	5GM9				REMARKS
1	5GM-2582W-00	DISC, REAR BRAKE 2	1				
2	90109-083G4	BOLT	3				
3	5GM-2580W-01	CALIPER ASSY, REAR 2	1				
4	5GM-W0057-00	.PISTON ASSY, CALIPER	1				
5	4TT-W0047-00	..CALIPER SEAL KIT	1				
6	5GM-25914-00	.PIN, SLIDE	2				
7	4TT-25937-00	.BOOT 2	2				
8	5GM-W0046-00	.BRAKE PAD KIT 2	1				
9	4TT-25919-00	.SUPPORT, PAD	2				
10	5GM-W0048-00	.BLEED SCREW KIT	1				
11	5EB-25828-00	.SHIM, CALIPER	2				
12	5GM-25828-00	.SHIM, CALIPER	2				
13	90105-10638	BOLT, WASHER BASED	3				

FIG. 27 STEERING HANDLE. CABLE

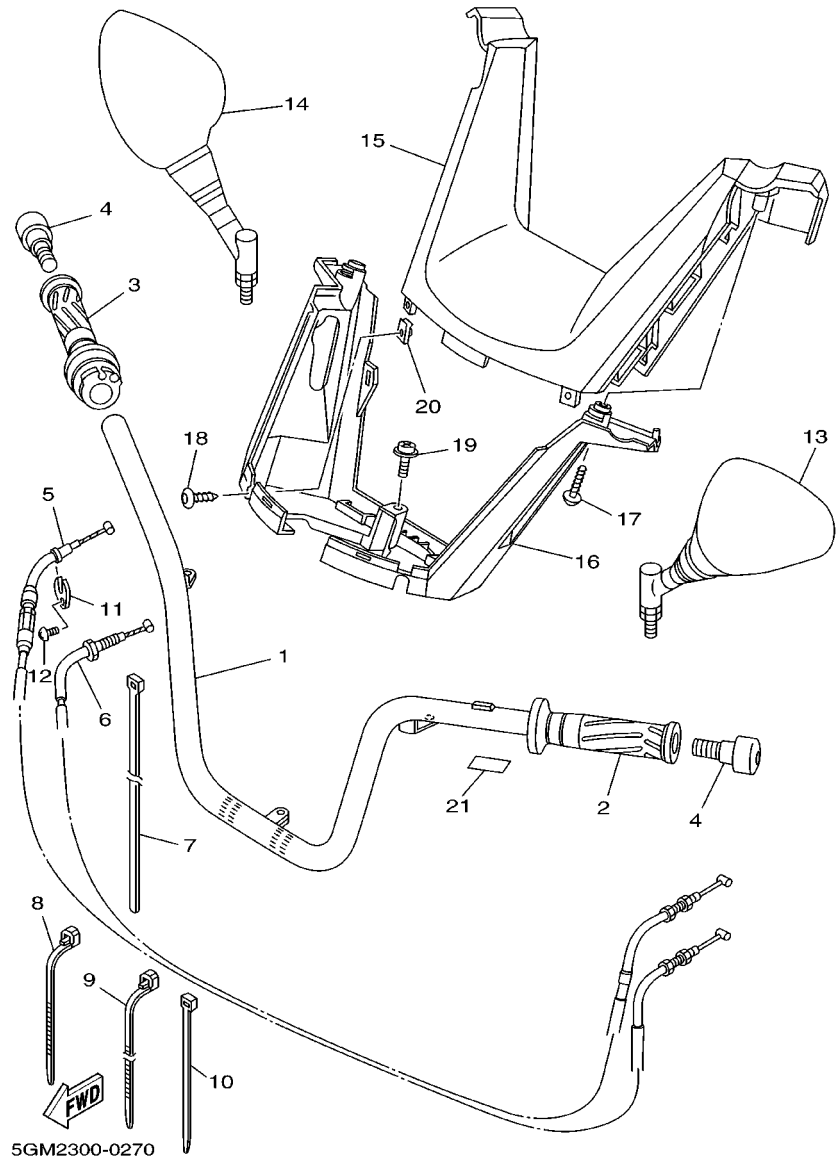

REF. NO.	PART NO.	DESCRIPTION	5GM9				REMARKS
1	5CG-26110-01	HANDLE COMP.	1				
2	4YR-26241-01	GRIP (LEFT)	1				
3	4YR-26240-01	GRIP ASSY	1				
4	33M-26246-00	END, GRIP	2				
5	5GM-26311-00	CABLE, THROTTLE 1	1				
6	5GM-26312-00	CABLE, THROTTLE 2	1				
7	90464-20258	CLAMP	1				
8	90464-15195	CLAMP	2				
9	90460-15126	CLAMP, HOSE	1				
10	90465-13152	CLAMP	1				
11	5H0-26393-00	HOLDER	1				
12	98507-05008	SCREW, PAN HEAD	1				
13	5CG-26280-01	REAR VIEW MIRROR ASSY (LEFT)	1				
14	5CG-26290-01	REAR VIEW MIRROR ASSY (RIGHT)	1				
15	5CG-26143-00	COVER, HANDLEBAR UPPER 1	1				
16	5CG-26144-01	COVER, HANDLEBAR LOWER 1	1				
17	90167-05080	SCREW, TAPPING	2				
18	90167-05079	SCREW, TAPPING	2				
19	90159-05028	SCREW, WITH WASHER	1				
20	90183-05042	NUT, SPRING	2				
21	1UF-15379-00	SEAL, CRANKCASE	1				

FIG. 28 FRONT MASTER CYLINDER

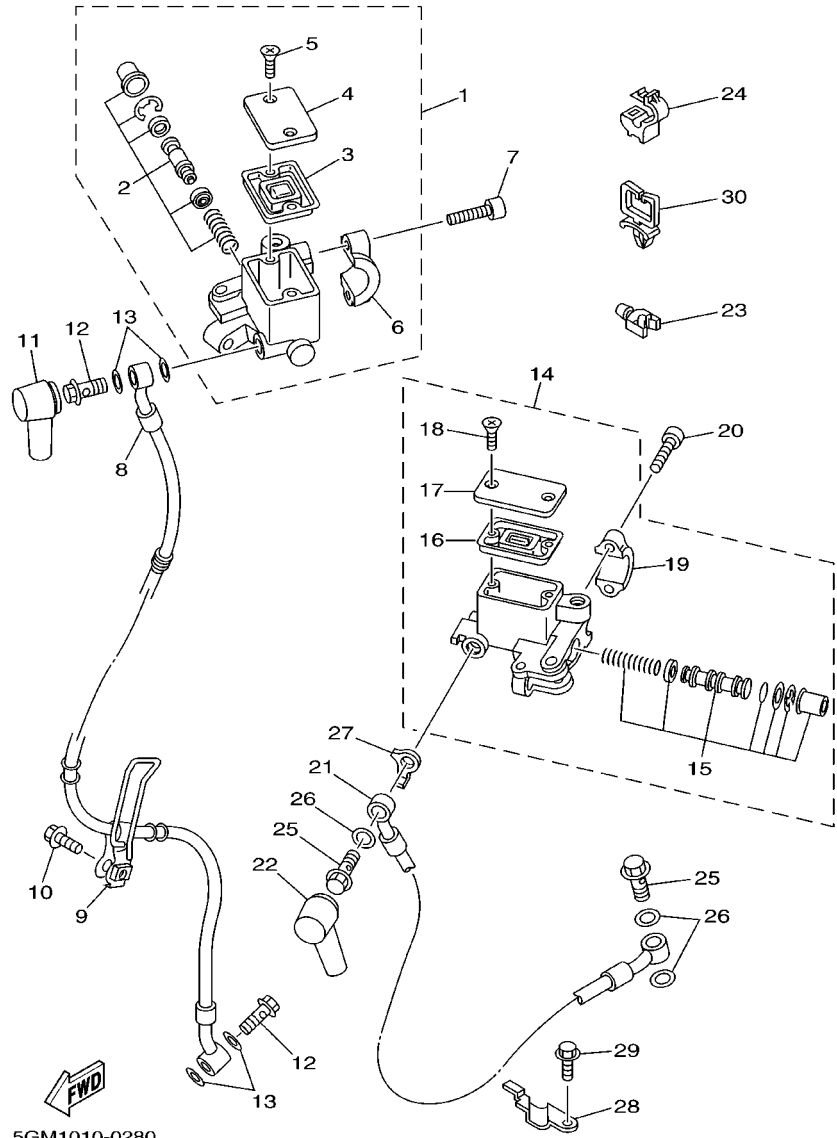

REF. NO.	PART NO.	DESCRIPTION	5GM9				REMARKS
1	5CG-2583T-11	MASTER CYLINDER ASSY	1				
2	59X-W0041-00	.CYLINDER KIT, MASTER	1				
3	55U-25854-00	.DIAPHRAGM, RESERVOIR	1				
4	2KF-25852-01	.CAP, RESERVOIR	1				
5	98706-04012	.SCREW, FLAT HEAD	2				
6	56A-25867-00	.BRACKET, MASTER CYLINDER	1				
7	91317-06025	BOLT	2				
8	5CG-25872-00	HOSE, BRAKE 1	1				
9	4HC-25876-00	HOLDER, BRAKE HOSE 2	1				
10	95807-06020	BOLT, FLANGE	1				
11	4L0-25862-01	BOOT, MASTER CYLINDER	1				
12	90401-10159	BOLT, UNION	2				
13	90201-10118	WASHER, PLATE	4				
14	5CG-2583T-01	MASTER CYLINDER ASSY	1				
15	5CG-W0041-00	.CYLINDER KIT, MASTER	1				
16	3RW-25854-00	.DIAPHRAGM, RESERVOIR	1				
17	3RW-25852-00	.CAP, RESERVOIR	1				
18	98706-04012	.SCREW, FLAT HEAD	2				
19	3RW-25867-00	.BRACKET, MASTER CYLINDER	1				
20	91317-06025	BOLT	2				
21	5GM-2584A-00	BRAKE HOSE ASSY	1				
22	4L0-25862-01	BOOT, MASTER CYLINDER	1				
23	5CG-81677-00	CLAMP 1	1				
24	90464-05188	CLAMP	2				
25	90401-10159	BOLT, UNION	2				
26	90201-10118	WASHER, PLATE	3				
27	5CG-25844-00	WASHER, LOCK	1				

FIG. 29 STAND, FOOTREST

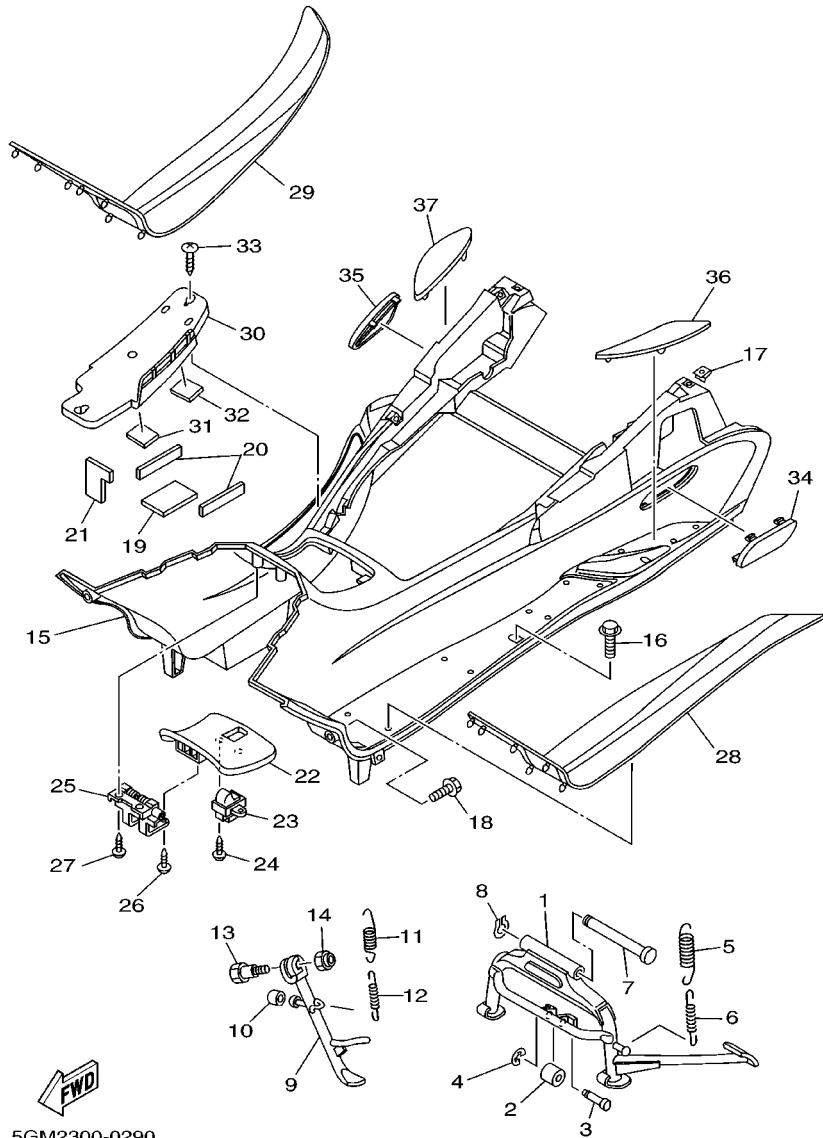

REF. NO.	PART NO.	DESCRIPTION	5GM9	REMARKS
1	4HC-27111-01	STAND, MAIN	1	
2	4HC-27114-00	STOPPER, MAIN STAND	1	
3	4HC-27112-00	SHAFT, MAIN STAND	1	
4	99001-04600	CIRCLIP	1	
5	90506-40175	SPRING, TENSION	1	
6	90506-20158	SPRING, TENSION	1	
7	58K-27112-02	SHAFT, MAIN STAND	1	
8	93430-12008	CIRCLIP	1	
9	5GM-27311-00	STAND, SIDE	1	
10	3VR-27114-00	STOPPER, MAIN STAND	1	
11	90506-26001	SPRING, TENSION	1	
12	90506-18224	SPRING, TENSION	1	
13	90109-10473	BOLT	1	
14	90185-10110	NUT, SELF-LOCKING	1	
15	5GM-27481-01	BOARD, FOOTREST	1	
16	90119-06060	BOLT, WITH WASHER	4	
17	90183-05042	NUT, SPRING	26	
18	97707-50016	SCREW, TAPPING	4	
19	5GM-27414-00	DAMPER, FOOTREST	1	
20	5GM-27424-00	DAMPER, FOOTREST 2	1	
21	5GM-27485-00	SEAL	1	
22	5GM-27453-00	COVER 1	1	
23	5GM-21780-00	LOCK ASSY	1	
24	97707-40512	SCREW, TAPPING	2	
25	5GM-2849E-00	HINGE 4	1	
26	97707-40010	SCREW, TAPPING	2	
27	97707-50016	SCREW, TAPPING	4	

FIG. 29 STAND. FOOTREST

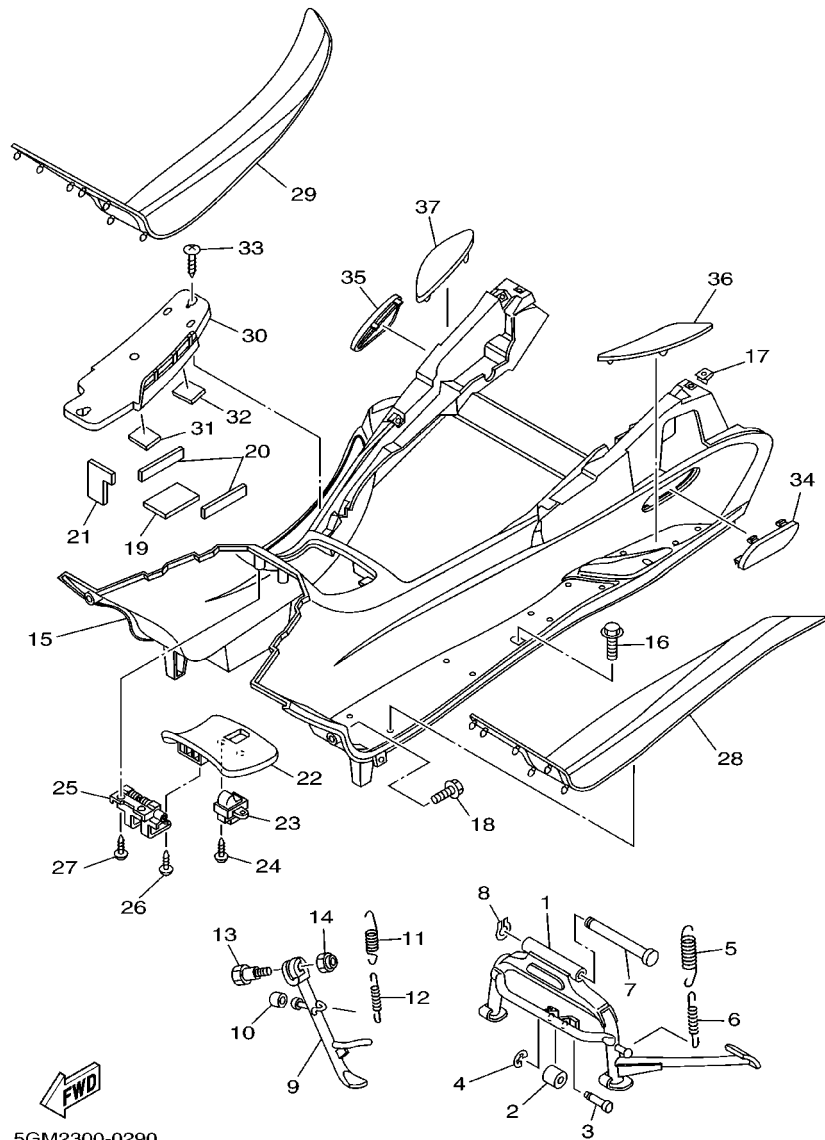

5GM2300-0290

REF. NO.	PART NO.	DESCRIPTION	5GM9				REMARKS
28	5GM-27483-00	MAT 1	1				
29	5GM-27484-00	MAT 2	1				
30	5GM-27463-00	COVER 2	1				
31	5GM-27482-00	MOLD, FOOTREST	1				
32	5GM-27492-00	MOLD, FOOTREST 2	1				
33	97707-50012	SCREW, TAPPING	2				
34	5GM-27475-00	CAP 1	1				
35	5GM-27476-00	CAP 2	1				
36	5GM-27486-00	COVER 1	1				
37	5GM-27487-00	COVER 2	1				

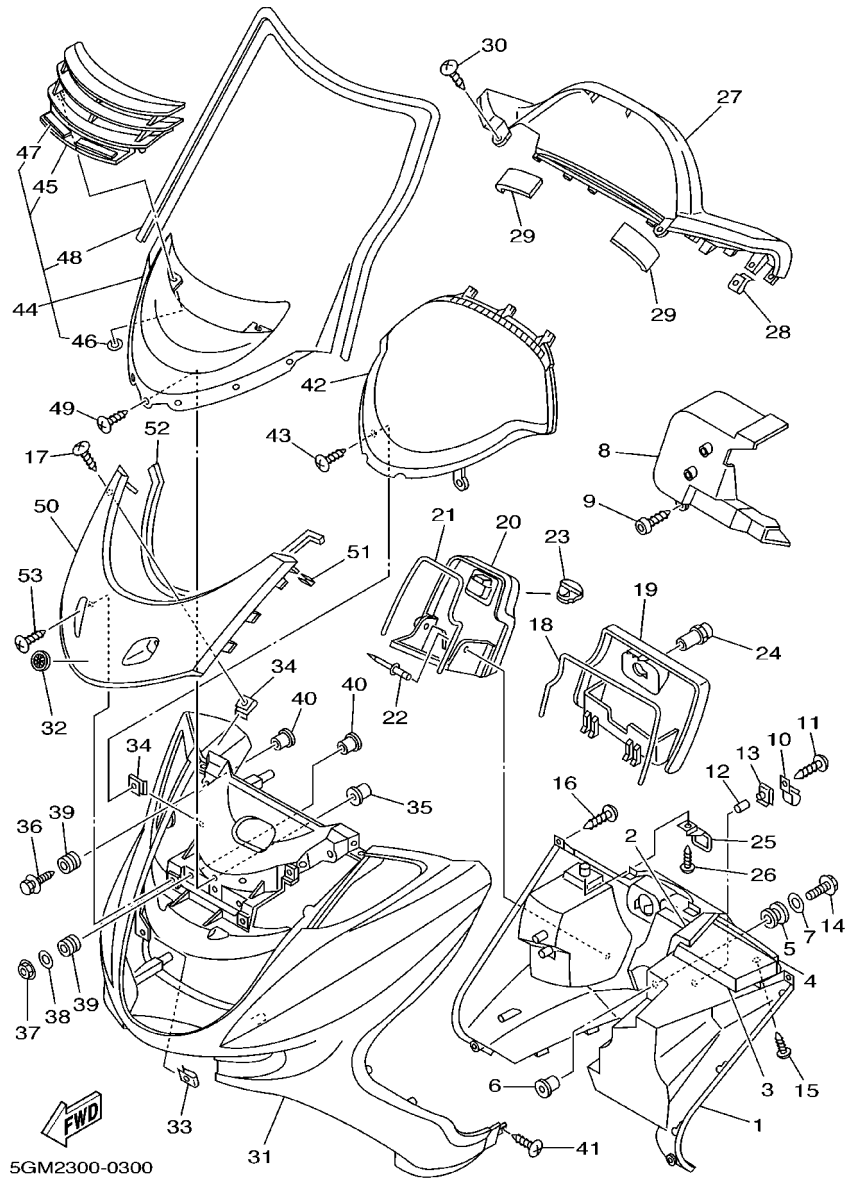
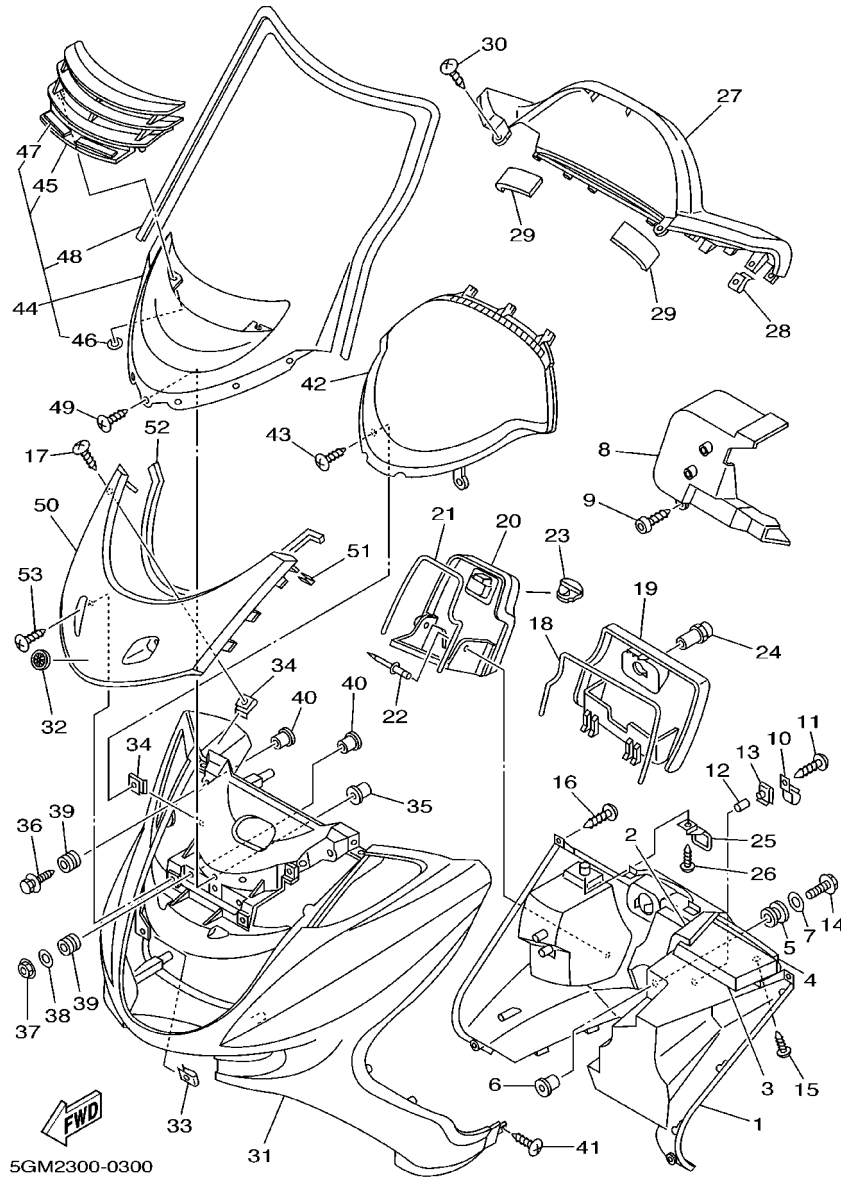

FIG. 30 LEG SHIELD

REF. NO.	PART NO.	DESCRIPTION	5GM9				REMARKS
1	5GM-28300-A0	LEG SHIELD ASSY	1				
2	5GM-28415-00	DAMPER 1	1				
3	5GM-28416-00	DAMPER 2	1				
4	5GM-28435-00	DAMPER 4	1				
5	90480-13398	GROMMET	1				
6	90387-065J6	COLLAR	1				
7	90201-086J0	WASHER, PLATE	1				
8	5GM-2835U-00	PANEL 1	1				
9	3KJ-24453-00	SCREW	2				
10	4HC-21796-01	HINGE	1				
11	97707-40512	SCREW, TAPPING	2				
12	90445-057G5	HOSE (L10)	1				
13	90183-04027	NUT, SPRING	2				
14	90119-06096	BOLT, WITH WASHER	1				
15	90167-05079	SCREW, TAPPING	4				
16	97707-50016	SCREW, TAPPING	4				
17	90167-05079	SCREW, TAPPING	4				
18	5GM-28371-00	DAMPER	1				
19	5GM-2839K-00	LID 1	1				
20	5GM-2478A-00	LID ASSY	1				
21	5GM-28372-00	DAMPER	1				
22	90269-08066	RIVET	1				
23	5GM-2837G-00	LOCK 1	1				
24	4BH-21708-11	LOCK ASSY 2	1				
25	5GM-2837H-00	LOCK 2	1				
26	97707-40512	SCREW, TAPPING	2				
27	5GM-2836K-02	PANEL, INNER 1	1				

FIG. 30 LEG SHIELD



REF. NO.	PART NO.	DESCRIPTION	5GM9				REMARKS
28	90183-05042	NUT, SPRING	4				
29	5GM-2836T-00	DAMPER, LOCATING 1	2				
30	97707-50012	SCREW, TAPPING	4				
31	5GM-28351-01-0L	BODY, COWLING	1				UR MAS
	5GM-28351-01-P0	BODY, COWLING	1				UR VDDBC4
	5GM-28351-01-JY	BODY, COWLING	1				UR MYM
	5GM-28351-01-P5	BODY, COWLING	1				UR VDBMA
32	5GM-2836B-01	TUNING FORK MARK	1				
33	90183-06053	NUT, SPRING	4				
34	90183-05042	NUT, SPRING	6				
35	90179-05523	NUT	7				
36	90119-06163	BOLT, WITH WASHER	2				
37	95704-06500	NUT, FLANGE	2				
38	90201-06057	WASHER, PLATE	2				
39	90480-13398	GROMMET	4				
40	90387-067N5	COLLAR	4				
41	97707-50012	SCREW, TAPPING	2				
42	5GM-2836L-00	PANEL, INNER 2	1				
43	97707-50012	SCREW, TAPPING	2				
44	5GM-28380-10	WINDSCREEN ASSY	1				
45	5GM-2838B-00	.GRILL ASSY	1				
46	90183-05004	.NUT, SPRING	2				
47	5GM-28344-00	.TAPE	2				
48	5GM-28376-00	.TRIM	1				
49	90150-05024	SCREW, ROUND HEAD	7				
50	5GM-28345-01-0L	MOLE 1	1				UR MAS
	5GM-28345-01-P2	MOLE 1	1				UR VDDBC4

FIG. 30 LEG SHIELD

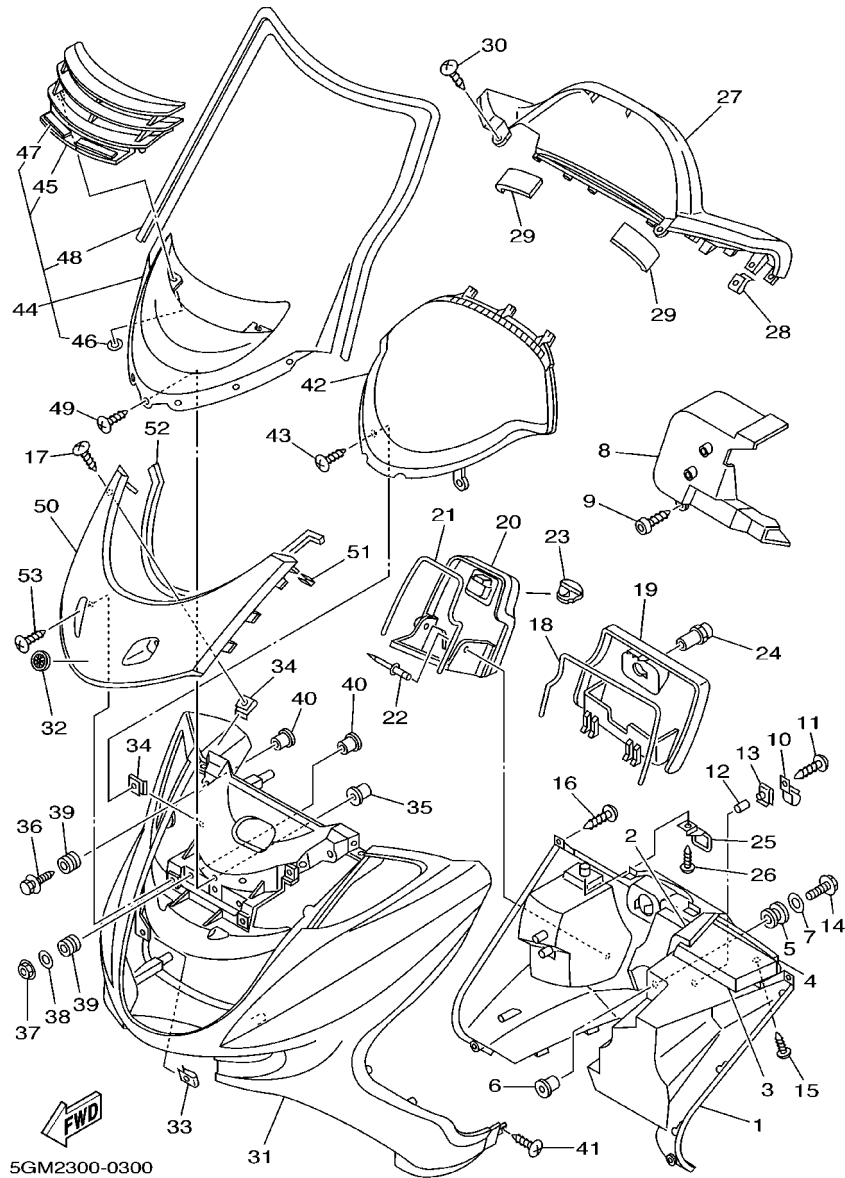

REF. NO.	PART NO.	DESCRIPTION	5GM9			REMARKS
50	5GM-28345-01-JY	MOLE 1	1			UR MYM
	5GM-28345-01-P4	MOLE 1	1			UR VDBMA
51	5GM-28379-00	HOOK	2			
52	5GM-28347-00	MOLE 3	1			
53	90167-05079	SCREW, TAPPING	2			

FIG. 31 GENERATOR

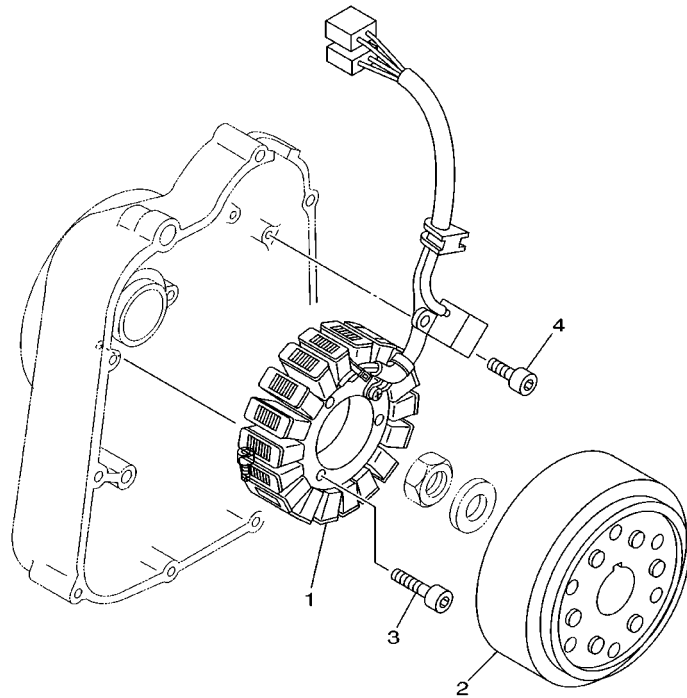

REF. NO.	PART NO.	DESCRIPTION	5GM9				REMARKS
1	5GM-81410-00	STATOR ASSY	1				
2	5GM-81450-00	ROTOR ASSY	1				
3	91317-06030	BOLT	3				
4	91317-05012	BOLT	2				

 5GM1010-0310

FIG. 32 STARTING MOTOR

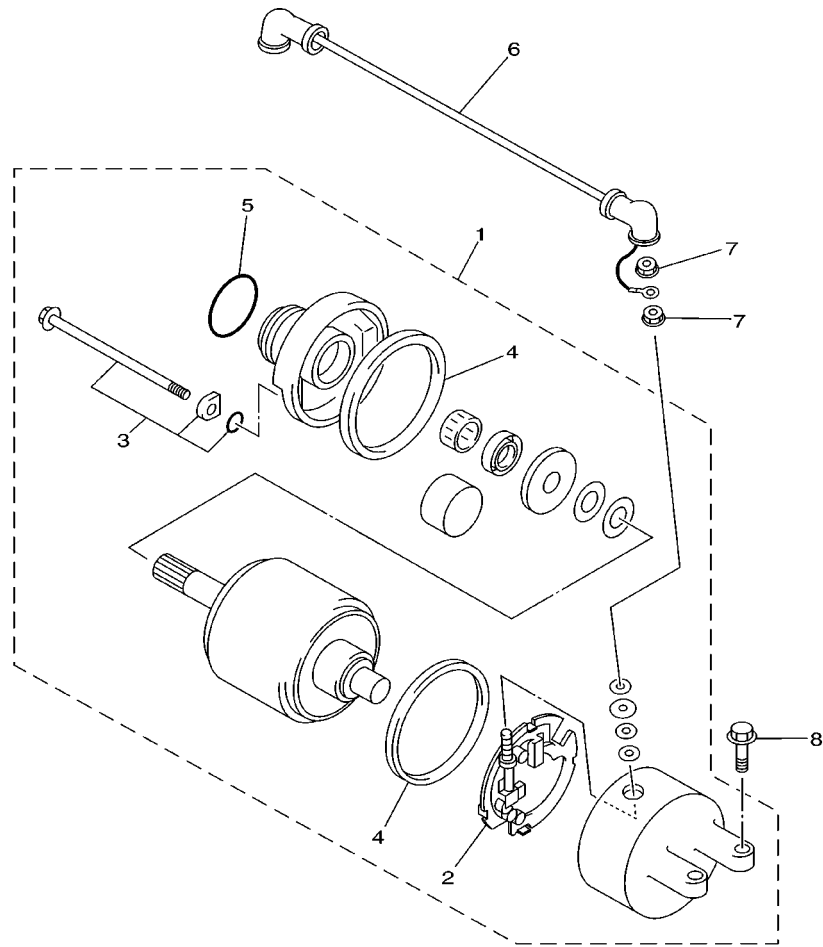

REF. NO.	PART NO.	DESCRIPTION	5GM9				REMARKS
1	4HC-81890-00	MOTOR ASSY	1				
2	3KS-81840-00	.BRUSH HOLDER ASSY	1				
3	3WP-81826-00	.BOLT	2				
4	11H-81844-00	.GASKET	2				
5	1FK-81847-00	.O-RING	1				
6	5GM-81815-00	CORD, STARTER MOTOR	1				
7	4XV-8182A-00	NUT	2				
8	95817-06025	BOLT, FLANGE	2				



5GM1010-0320

FIG. 33 FLASHER LIGHT

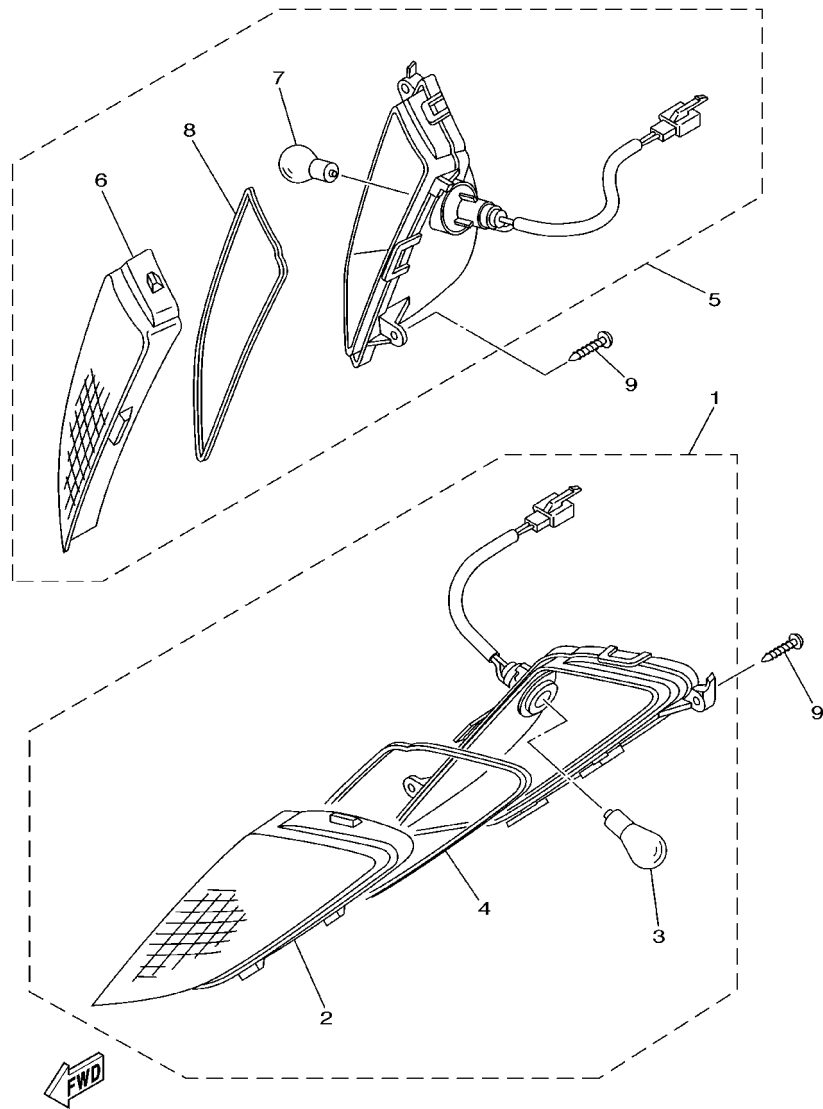

5GM7700-0330

REF. NO.	PART NO.	DESCRIPTION	5GM9	REMARKS
1	5GM-83310-10	FRONT FLASHER LIGHT ASSY 1	1	
2	5GM-83312-00	.LENS, FLASHER	1	
3	32H-83331-00	.BULB, FLASHER (12V-21W)	1	
4	5GM-83313-00	.GASKET, FLASHER LENS	1	
5	5GM-83320-10	FRONT FLASHER LIGHT ASSY 2	1	
6	5GM-83322-00	.LENS, FLASHER 2	1	
7	32H-83331-00	.BULB, FLASHER (12V-21W)	1	
8	5GM-83313-00	.GASKET, FLASHER LENS	1	
9	97707-50016	SCREW, TAPPING	4	

FIG. 34 METER

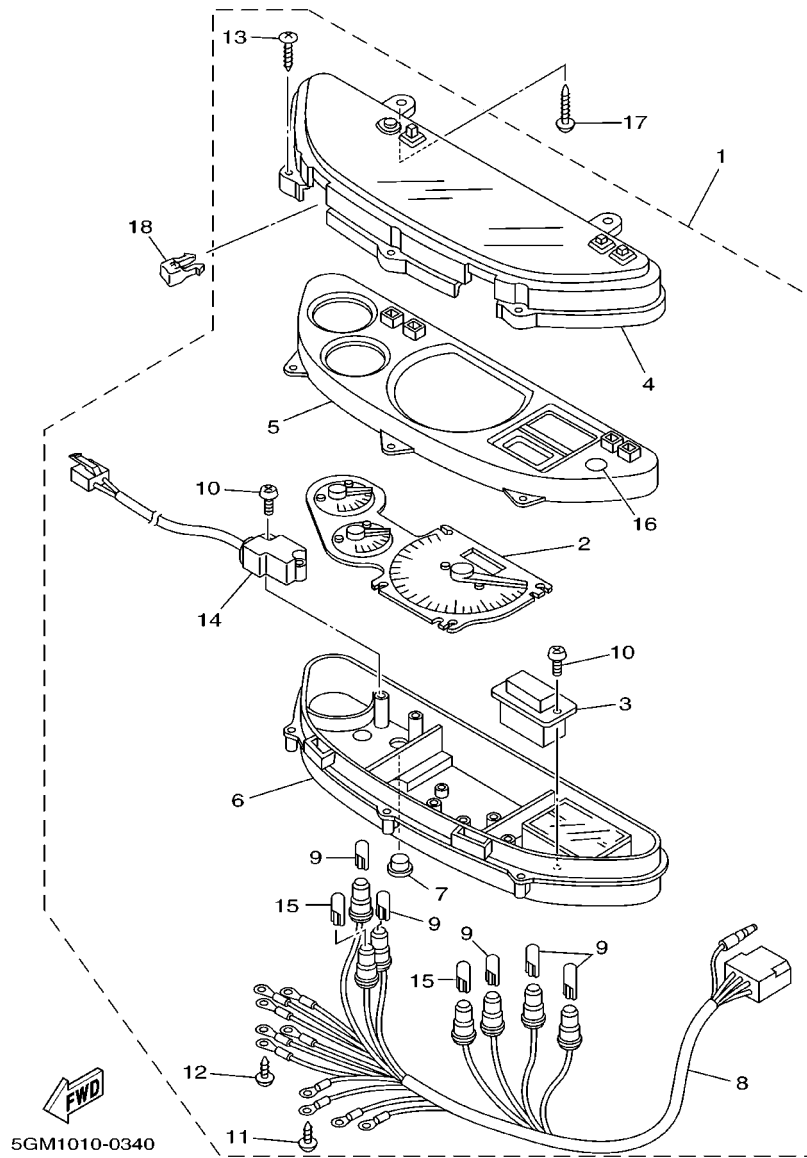

REF. NO.	PART NO.	DESCRIPTION	5GM9				REMARKS
1	5GM-83500-00	SPEEDOMETER ASSY	1				UR
	5GM-83500-20	SPEEDOMETER ASSY	1				UR FOR GBR
2	5GM-83510-00	.SPEEDOMETER ASSY	1				UR
	5GM-83510-20	.SPEEDOMETER ASSY	1				UR FOR GBR
3	5GM-83740-00	.DIGITAL CLOCK ASSY	1				
4	5GM-83511-00	.LENS, SPEEDOMETER	1				
5	5GM-83612-00	.COVER, METER PANEL	1				
6	5GM-8353H-00	.CASE, UNDER	1				
7	3SX-8352K-00	.PLUG, BLIND	2				
8	5GM-83509-00	.SOCKET CORD ASSY	1				
9	1YT-83517-00	.BULB (12V-1.7W, T10)	5				
10	97707-30512	.SCREW, TAPPING	4				
11	5GM-8362Y-00	.SCREW, SPECIAL	4				
12	5GM-83616-00	.SCREW, TAPPING	6				
13	97707-40016	.SCREW, TAPPING	5				
14	4HC-83964-00	.SWITCH	1				
15	4R0-83517-00	.BULB (12V-3.4W T10)	2				
16	5DM-2341B-00	.EMBLEM	1				
17	97707-50014	SCREW, TAPPING	2				
18	4HC-2837G-00	LOCK 1	2				

FIG. 35 HEADLIGHT

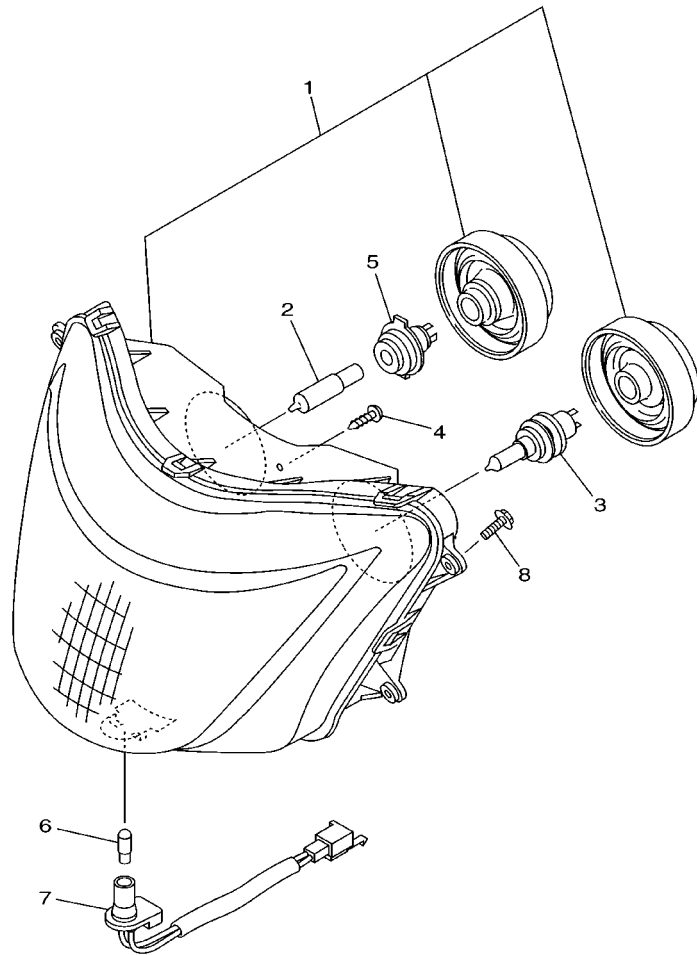

5GM2300-0350

REF. NO.	PART NO.	DESCRIPTION	5GM9	REMARKS
1	5GM-84310-10	HEADLIGHT UNIT ASSY	1	UR
	5GM-84310-20	HEADLIGHT UNIT ASSY	1	UR FOR GBR
2	4SV-84314-00	BULB (12V-55W)	1	
3	8G9-84314-00	BULB (12V-60/55W)	1	(H4)HALOGEN
4	97702-40912	SCREW, TAPPING	5	
5	4SV-84350-00	SOCKET CORD ASSY 2	1	
6	4SV-84347-00	BULB (12V-5W)	1	
7	4XV-84312-00	SOCKET CORD ASSY 1	1	
8	90119-06052	BOLT, WITH WASHER	4	

FIG. 36 TAILLIGHT

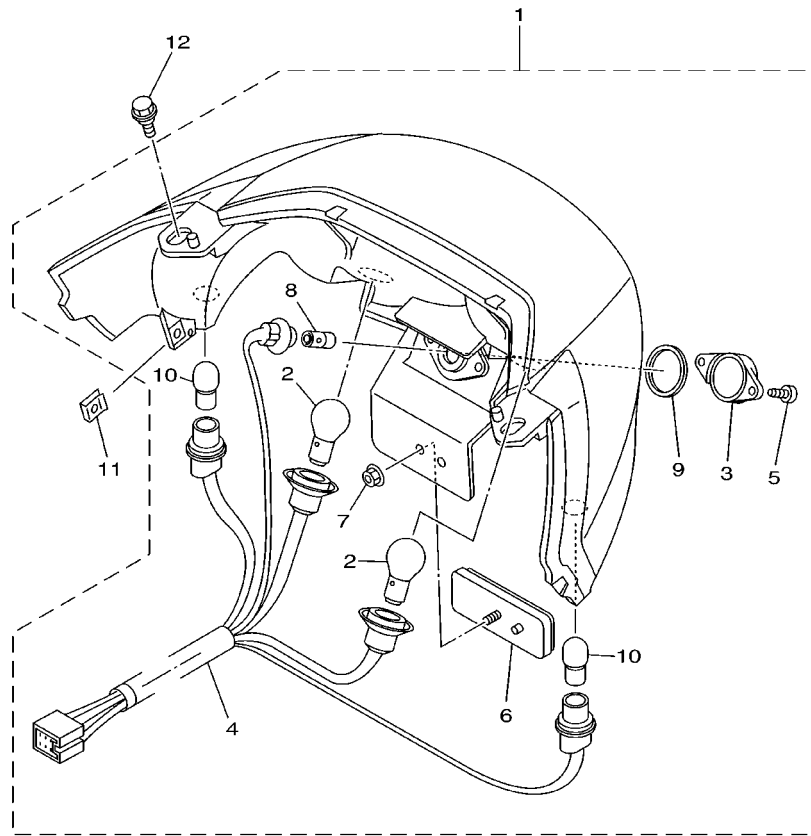

REF. NO.	PART NO.	DESCRIPTION	5GM9				REMARKS
1	5GM-84710-00	TAILLIGHT UNIT ASSY	1				
2	31L-84714-00	.BULB, TAILLIGHT (12V-21/5W)	2				
3	4HC-84743-00	.LENS, LICENCE LIGHT	1				
4	5GM-84735-00	.CORD ASSY	1				
5	97706-40114	.SCREW, TAPPING	2				
6	3Y6-85130-02	.REAR REFLECTOR ASSY	1				
7	95702-05500	.NUT, FLANGE	1				
8	4HC-84744-00	.BULB (12V-5W)	1				
9	4HC-84545-00	.GASKET, LENS	1				
10	5GM-83311-00	.BULB (12V 18W)	2				
11	90183-05042	NUT, SPRING	2				
12	90109-063F1	BOLT	2				



5GM1010-0360

FIG. 37 HANDLE SWITCH. LEVER

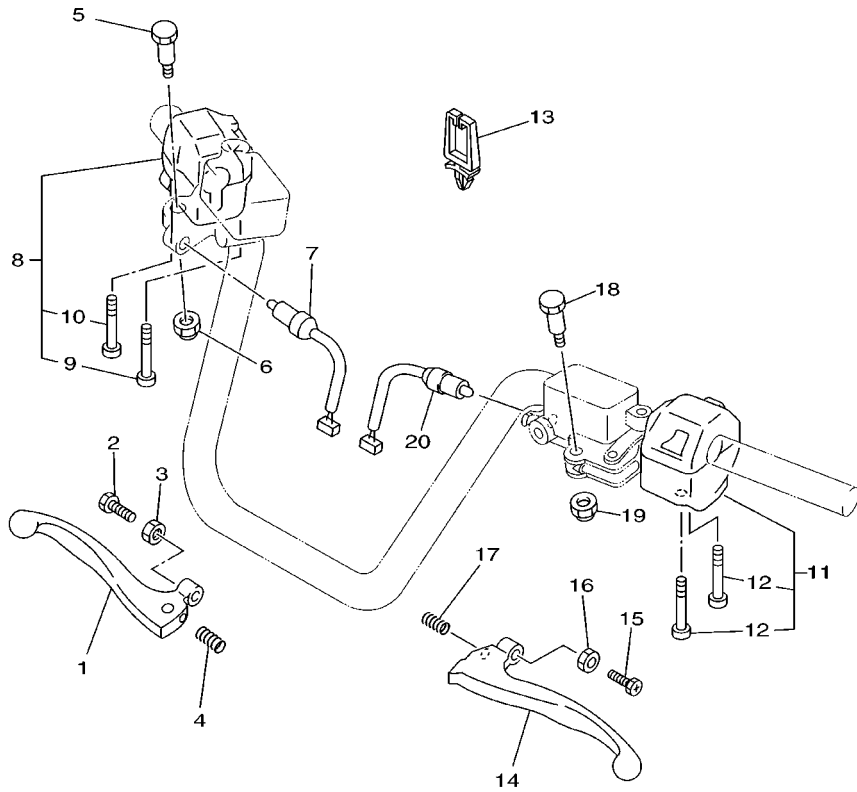

REF. NO.	PART NO.	DESCRIPTION	5GM9				REMARKS
1	5CG-83922-00	LEVER 2	1				
2	90143-06024	SCREW, HEXAGON	1				
3	90170-06010	NUT	1				
4	90501-10312	SPRING, COMPRESSION	1				
5	90109-06577	BOLT	1				
6	95607-06100	NUT, U	1				
7	4FU-83980-00	FRONT STOP SWITCH ASSY	1				
8	4UC-83963-10	SWITCH, HANDLE 3 (RIGHT)	1				
9	98507-05040	.SCREW, PAN HEAD	1				
10	98507-05045	.SCREW, PAN HEAD	1				
11	5GM-83972-10	SWITCH, HANDLE 4	1				
12	98507-05055	.SCREW, PAN HEAD	2				
13	90464-05141	CLAMP	1				
14	5CG-83912-10	LEVER 1	1				
15	90143-06024	SCREW, HEXAGON	1				
16	90170-06010	NUT	1				
17	90501-10312	SPRING, COMPRESSION	1				
18	90109-06577	BOLT	1				
19	95607-06100	NUT, U	1				
20	4FU-83980-00	FRONT STOP SWITCH ASSY	1				



5GM1010-0370

FIG. 38 ELECTRICAL 1

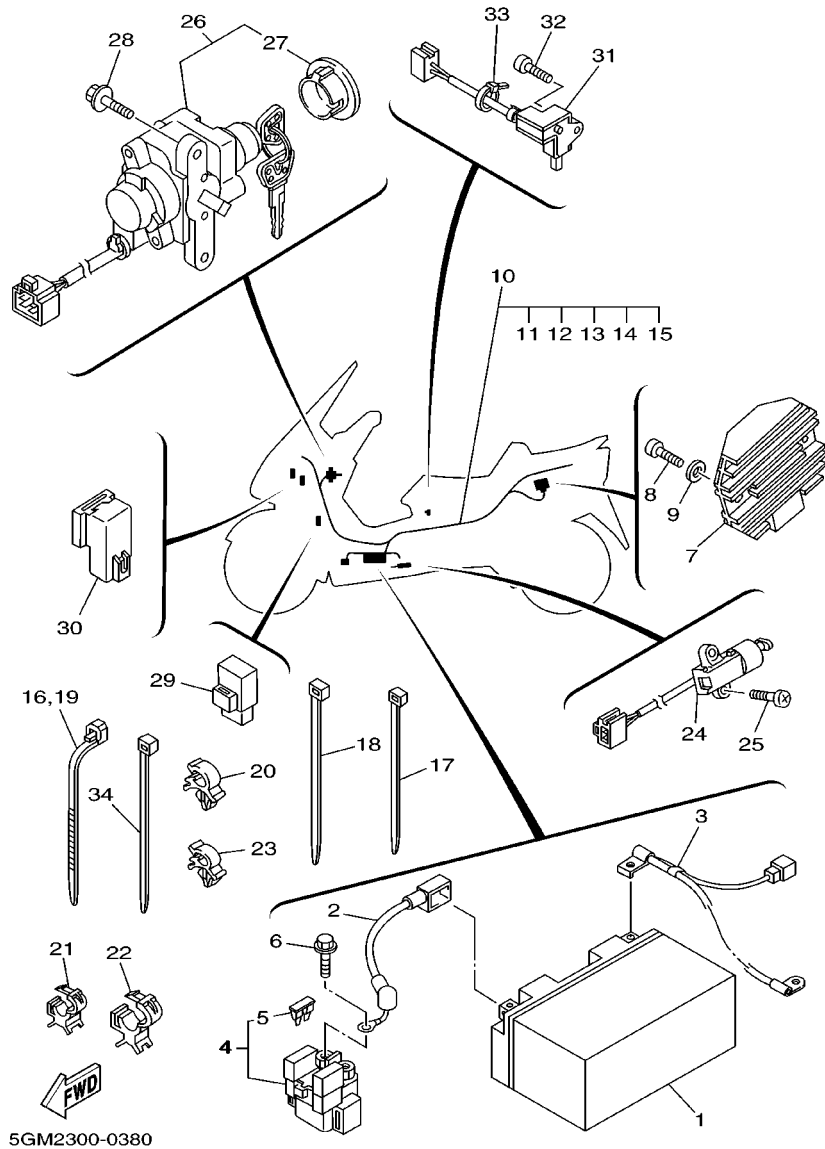

5GM2300-0380

REF. NO.	PART NO.	DESCRIPTION	5GM9				REMARKS
1	4UC-82100-01	BATTERY (GS GT7B-4)	1				
2	5GM-82115-00	WIRE, PLUS LEAD	1				
3	5GM-82116-00	WIRE, MINUS LEAD	1				
4	4DN-81940-00	STARTER RELAY ASSY	1				
5	1AE-82151-00	.FUSE (30A-BL)	2				
6	95027-06008	BOLT, FLANGE	2				
7	4JH-81960-01	RECTIFIER & REGULATOR ASSY	1				
8	98507-06025	SCREW, PAN HEAD	2				
9	92907-06600	WASHER, PLATE	2				
10	5GM-82590-10	WIRE HARNESS ASSY	1				
11	4WA-81980-00	.DIODE ASSY	1				
12	5JJ-82151-40	.FUSE (4A-BL)	2				
13	5JJ-82151-10	.FUSE (15A-BL)	3				
14	5JJ-82151-00	.FUSE (7.5A-BL)	2				
15	5JJ-82151-30	.FUSE (10A-BL)	2				
16	90464-13073	CLAMP	1				
17	90464-20181	CLAMP	1				
18	90464-15195	CLAMP	1				
19	90464-13073	CLAMP	3				
20	90464-11003	CLAMP	5				
21	90464-10190	CLAMP	2				
22	90464-15192	CLAMP	4				
23	90464-07001	CLAMP	3				
24	3LD-82566-50	SWITCH, SIDE STAND	1				
25	90157-05079	SCREW, PAN HEAD	2				
26	5GM-82501-11	MAIN SWITCH STEERING LOCK	1				
27	4HC-82552-00	.CAP, SWITCH	1				

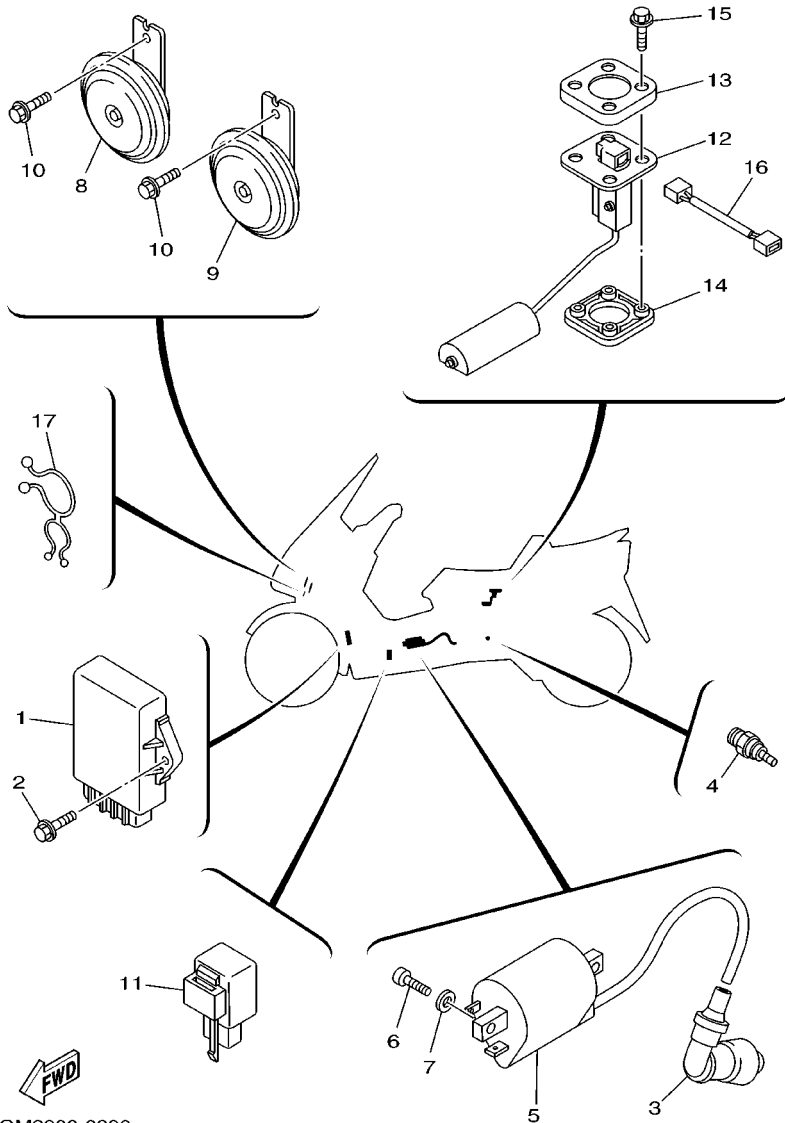

FIG. 39 ELECTRICAL 2

REF. NO.	PART NO.	DESCRIPTION	5GM9	REMARKS
1	5GM-82305-11	IGNITOR UNIT ASSY	1	
2	95027-06016	BOLT, FLANGE	2	
3	4BP-82370-00	PLUG CAP ASSY	1	
4	46X-83591-00	THERMO UNIT	1	
5	4HC-82310-00	IGNITION COIL ASSY	1	
6	98507-05016	SCREW, PAN HEAD	2	
7	92907-05600	WASHER, PLATE	2	
8	3TB-83371-01	HORN	1	
9	5GM-83371-10	HORN	1	
10	95807-06010	BOLT, FLANGE	2	
11	3GM-83350-01	FLASHER RELAY ASSY	1	
12	5GM-85752-00	SENDER UNIT ASSY, FUEL METER	1	
13	2JG-85757-00	RETAINER	1	
14	4US-85753-00	GASKET, SENDER UNIT	1	
15	90119-05071	BOLT, WITH WASHER	4	
16	5GM-82509-00	WIRE, SUB LEAD	1	
17	90464-25098	CLAMP	1	

NUMERICAL INDEX

PARTNO.	GRID NO.	PARTNO.	GRID NO.	PARTNO.	GRID NO.	PARTNO.	GRID NO.	PARTNO.	GRID NO.	PARTNO.	GRID NO.
5CG-W0041-00	D - 11	5GM-12405-00	B - 7	4UC-14341-00	B - 12	5GM-15100-00	B - 15	4HC-17654-00	C - 6	1AA-21874-00	C - 12
59X-W0041-00	D - 11	4HC-12411-00	B - 7	4UC-14341-10	B - 12	36Y-15189-00	C - 4	5GM-17660-00	C - 6	5GM-22100-00	C - 13
4HM-W0045-00	D - 7	4HC-12413-00	B - 7	38V-14342-22	B - 12	5GM-15199-00	B - 15	4CW-17664-00	C - 6	5GM-22210-00	C - 13
5GM-W0046-00	D - 9	5GM-12420-01	B - 6	50M-14343-64	B - 12	5GM-15316-00	C - 3	4HC-17670-10	C - 6	164-22216-00	B - 15
4FU-W0047-50	D - 7	4HC-12421-00	B - 6	50M-14355-00	B - 12	5GM-15326-00	C - 3	5GM-21110-01	C - 9		C - 13
4TT-W0047-00	D - 9	4HC-12422-01	B - 6	4KL-14384-00	B - 11	5GM-15335-00	C - 3	5CG-21279-00	C - 10	5GM-23100-00	C - 14
5GM-W0048-00	D - 9	5GM-12426-00	B - 6	25N-14385-00	B - 11	5GM-15337-00	C - 3	5GM-21417-00	C - 9	5GM-23110-00	C - 14
51L-W0048-00	D - 7	4HC-12428-10	B - 6	4KL-14386-00	B - 11	5GM-15338-00	C - 3	5CG-21420-01	C - 9	4HC-23111-00	C - 14
4FU-W0057-50	D - 7	11H-12438-00	B - 6	4HC-14390-00	B - 11	4HC-15351-00	B - 9	4HC-21480-00	C - 9	4HC-23114-00	C - 14
5GM-W0057-00	D - 9	5GM-12443-00	B - 7	4KL-14397-00	B - 11	2T4-15363-00	B - 15	4HC-21511-01-JY	C - 10	4HC-23125-20	C - 14
5GM-11101-00	B - 2	4HC-12446-00	B - 6	4KL-14404-00	B - 11	4HC-15363-00	C - 3	4HC-21511-01-PE	C - 10	4HC-23126-10	C - 14
4GA-1111F-00	B - 5	5GM-12450-01	B - 6	5GM-1441A-00	B - 10	4HC-15378-00	B - 15	4HC-21511-01-P5	C - 10	4HC-23136-10	C - 14
4G0-11133-10	B - 2	4HC-12459-00	B - 6	4HC-14411-00	B - 10	1UF-15379-00	D - 10	4HC-21511-01-OL	C - 10	5GM-23141-00	C - 14
4KB-11145-00	B - 5	5GM-12461-10	B - 7	5GM-14412-01	B - 10	5GM-15407-00	C - 3	5GM-21552-00	C - 10	2UJ-23144-00	C - 14
4HC-11160-00	B - 2	4JH-12462-00	B - 7	4HC-14429-00	B - 11	5GM-15411-00	C - 3	5GM-21629-00	D - 5	2UJ-23145-00	C - 14
4HC-11166-00	B - 2	5GM-12476-00	B - 7	5GM-14437-00	B - 10	5GM-15417-00	C - 3	5A8-21639-00	D - 5	22W-23146-L0	C - 14
4HC-11181-01	B - 2	5GM-12481-00	B - 7	4HC-14451-00	B - 10	5GM-15421-00	B - 15	4BH-21708-11	D - 15	22W-23153-L0	C - 14
3GC-11186-00	B - 2	5GM-12482-00	B - 7	4HC-14452-00	B - 10	5GM-15431-00	C - 3	5GM-2171L-00-JY	C - 11	509-23158-L0	C - 14
3GC-11187-00	B - 2	5GM-12483-00	B - 7	4HC-14453-01	B - 10	5GM-15451-00	C - 3	5GM-2171L-00-P0	C - 11	5GM-23170-00	C - 14
4HC-11311-00	B - 2	5GM-12484-00	B - 7	17W-14462-00	C - 3	4HC-15453-00	C - 3	5GM-2171L-00-P5	C - 11	4HC-23173-20	C - 14
4HC-11351-00	B - 2	5GM-12485-00	B - 7	4HC-14472-00	B - 10	4HC-15461-00	B - 15	5GM-2171L-00-OL	C - 11	278-23181-50	C - 14
5GM-11400-00	B - 3	5Y9-12491-00	E - 12	4KL-14536-00	B - 11	5GM-15471-00	C - 3	5GM-2171M-00-JY	C - 12	3G2-23183-00	C - 14
4HC-11603-00	B - 3	4HC-12576-00	B - 7	5GM-14565-00	B - 12	4HC-15472-00	C - 3	5GM-2171M-00-P0	C - 11	4HC-23184-10	C - 14
4HC-11605-00	B - 3	4HC-12577-00	B - 7	4HC-14592-00	B - 11	3KJ-15481-00	C - 3	5GM-2171M-00-P5	C - 12	5CG-23317-00	C - 15
4HC-11607-00	B - 3	4HC-12591-00	B - 7	5GM-14611-00	B - 13	5GM-15491-00	C - 3	5GM-2171M-00-OL	C - 11	5GM-23340-00	C - 14
4HC-11631-01	B - 3	4HC-13300-00	B - 9	3MT-14613-00	B - 13	4HC-15492-00	B - 15	5GM-2171N-00-JY	C - 12	5DM-2341B-00	E - 7
4JH-11633-00	B - 3	4HC-13325-00	B - 9	4HC-14628-00	B - 13	5GM-15499-00	C - 3	5GM-2171N-00-P0	C - 12	22F-2341E-00	C - 14
4HC-11636-01	B - 3	51Y-13411-00	B - 9	5GM-14711-01	B - 13	4HC-15512-00	C - 5	5GM-2171N-00-P5	C - 12	22F-23411-01	C - 14
4HC-11638-01	B - 3	4HC-13475-00	B - 9	4BH-14714-00	B - 13	4HC-15517-00	C - 5	5GM-2171N-00-OL	C - 12	22F-23412-01	C - 14
5GM-12111-00	B - 4	5GM-13542-00	B - 14	5GM-14718-00	B - 13	2HT-15521-00	C - 5	5GM-21711-01-JY	C - 11	3VP-23416-00	C - 15
4HC-12113-00	B - 4	4HC-13586-11	B - 10	5GM-14728-00	B - 13	4HC-15590-00	C - 5	5GM-21711-01-P0	C - 11	3YF-23418-00	C - 15
4HC-12114-00	B - 4	4HC-13595-00	B - 10	5GM-14738-00	B - 13	5GM-16111-00	C - 8	5GM-21711-01-P5	C - 11	4H7-23441-00-98	C - 15
4G0-12116-01	B - 4	2GV-13907-00	D - 2	5GM-14748-00	B - 13	5GM-16151-00	C - 8	5GM-21711-01-OL	C - 11	4HC-23442-11	C - 15
4G0-12117-00	B - 4	5GM-1410A-10	B - 11	4BD-14766-00	B - 13	5GM-16611-00	C - 6	5GM-21721-01-JY	C - 11	164-23462-00	C - 14
4G0-12118-00	B - 4	4HC-14103-00	B - 11	5GM-14766-00	B - 13	5GM-16620-00	C - 6	5GM-21721-01-P0	C - 11	341-23469-00	D - 5
5H0-12119-00	B - 4	5GM-14105-00	B - 11	5GM-14799-00	B - 13	5KD-16626-10	C - 6	5GM-21721-01-P5	C - 11	5GM-24110-10	D - 2
5H0-12121-01	B - 4	4KL-14115-00	B - 11	5GM-14803-00	B - 13	5GM-17211-00	C - 8	5GM-21721-01-OL	C - 11	5GM-2414A-00	D - 2
5H0-12146-00	B - 4	389-14147-00	B - 11	5GM-14806-00	B - 14	5GM-17411-00	C - 8	5GM-2173B-00	C - 12	5GM-2414G-00	D - 2
36X-12151-00	B - 4	4HC-14196-00	B - 12	5GM-14815-00	B - 13	5GM-17421-00	C - 8	5GM-21731-00	C - 12	5GM-2414H-00	D - 2
3Y1-12156-00	B - 4	4HC-14197-00	B - 12	5GM-1482K-00	B - 13	4HC-17611-00	C - 6	5GM-2177F-00	D - 4	5GM-24145-00	D - 2
4HC-12157-00	B - 5	5GM-14197-00	B - 12	5GM-14871-01	B - 13	5GM-17620-00	C - 6	5GM-21778-00	C - 11	5GM-24145-10	D - 2
2NX-12159-00	B - 4	4JP-14243-01	B - 11	5GM-14881-00	B - 13	4HC-17623-00	C - 6	5GM-21779-00	C - 11	5GM-24191-00	D - 2
4HC-12170-00	B - 5	5GM-14243-00	B - 12	5GM-14882-00	B - 14	4CW-17632-01	C - 6	5GM-21780-00	D - 13	5GM-24311-00	D - 2
4HC-12176-00	B - 5	4KL-14272-01	B - 11	5GM-14883-00	B - 14	5CG-17639-00	C - 6	4HC-21796-01	D - 15	5GM-24312-00	D - 2
2UJ-12210-01	B - 5	4HC-14286-00	B - 11	4HC-1490A-00	B - 11	5CG-17641-00	C - 6	1AA-21815-00	C - 12	1AE-24366-00	D - 2
4RF-12213-00	B - 5	5GM-14294-00	B - 10	4HC-1490H-08	B - 11	5GM-17644-00	C - 6	5GM-21816-00	C - 12	3KJ-24453-00	D - 15
4HC-12231-00	B - 5	5GM-14301-10	B - 11	5GM-1490J-00	B - 11	5GM-17649-00	C - 2	5GM-21817-00	C - 12	5GM-24492-00	D - 3
4HC-12241-00	B - 5	4HC-14340-00	B - 11	4HC-14958-00	B - 11	4HC-17653-00	C - 6	5GM-21871-00	C - 12	214-24535-00	B - 11

NUMERICAL INDEX

PARTNO.	GRID NO.	PARTNO.	GRID NO.	PARTNO.	GRID NO.	PARTNO.	GRID NO.	PARTNO.	GRID NO.	PARTNO.	GRID NO.
1FK-24560-00	D - 2	3RW-25852-00	D - 11	5GM-27483-00	D - 14	3KS-81840-00	E - 5	46X-83591-00	E - 13	90109-084F7	D - 5
3KJ-24602-03	D - 2	3RW-25854-00	D - 11	5GM-27484-00	D - 14	11H-81844-00	E - 5	5GM-83612-00	E - 7	90109-10473	D - 13
5GM-24667-00	D - 2	55U-25854-00	D - 11	5GM-27485-00	D - 13	1FK-81847-00	E - 5	5GM-83616-00	E - 7	90110-06202	D - 4
5GM-2467E-00	D - 4	4LO-25862-01	D - 11	5GM-27486-00	D - 14	5GM-81860-00	E - 12	5GM-8362Y-00	E - 7	90111-06015	B - 13
5GM-2470E-00	D - 4	3RW-25867-00	D - 11	5GM-27487-00	D - 14	4HC-81890-00	E - 5	5GM-83740-00	E - 7	90111-06020	B - 13
5GM-2470F-10	D - 4	56A-25867-00	D - 11	5GM-27492-00	D - 14	4DN-81940-00	E - 11	5GM-83740-00	E - 10	90116-08591	B - 15
5GM-2470F-21	D - 4	5CG-25872-00	D - 11	5GM-28100-00	D - 5	29U-81950-93	E - 12	5CG-83922-00	E - 10	90119-05071	E - 13
5GM-24704-00	D - 4	4HC-25875-01	C - 15	4KG-2814E-10	D - 5	4HC-81950-00	E - 12	4UC-83963-10	E - 10	90119-06044	C - 10
5GM-24710-11	D - 4	5GM-25875-00	C - 13	5GM-28300-A0	D - 15	4JH-81960-01	E - 11	4HC-83964-00	E - 7	90119-06052	E - 8
5GM-24723-00	D - 4	4HC-25876-00	D - 11	5GM-28344-00	E - 2	4WA-81980-00	E - 11	5GM-83972-10	E - 10	90119-06060	C - 10
5GM-24738-00	D - 4	5GM-25914-00	D - 9	5GM-28345-01-JY	E - 3	4UC-82100-01	E - 11	4FU-83980-00	E - 10		D - 13
5GM-24747-00	D - 4	4BP-25919-00	D - 7	5GM-28345-01-P2	E - 2	5GM-82115-00	E - 11	5GM-84310-10	E - 8	90119-06096	D - 15
5GM-24750-00	D - 4	4TT-25919-00	D - 9	5GM-28345-01-P4	E - 3	5GM-82116-00	E - 11	5GM-84310-20	E - 8	90119-06118	B - 8
5GM-24773-00-JY	D - 5	3YX-25929-00	D - 7	5GM-28345-01-0L	E - 2	1AE-82151-00	E - 11	4XV-84312-00	E - 8	90119-06163	E - 2
5GM-24773-00-P0	D - 4	3YX-25937-00	D - 7	5GM-28347-00	E - 3	5JJ-82151-00	E - 11	4SV-84314-00	E - 8	90143-06024	E - 10
5GM-24773-00-P5	D - 5	4TT-25937-00	D - 9	5GM-2835U-00	D - 15	5JJ-82151-10	E - 11	8G9-84314-00	E - 8	90150-05024	E - 2
5GM-24773-00-0L	D - 4	5R2-25937-00	D - 7	5GM-28351-01-JY	E - 2	5JJ-82151-30	E - 11	4HC-84347-00	D - 4	90153-06029	B - 2
5GM-24774-00	D - 4	5CG-26110-01	D - 10	5GM-28351-01-P0	E - 2	5JJ-82151-40	E - 11	4SV-84347-00	E - 8	90154-06014	C - 10
5GM-2478A-00	D - 15	5CG-26143-00	D - 10	5GM-28351-01-P5	E - 2	5GM-82305-11	E - 13	4SV-84350-00	E - 8	90157-04088	C - 6
5GM-2478D-01	D - 5	5CG-26144-01	D - 10	5GM-28351-01-0L	E - 2	4HC-82310-00	E - 13	4HC-84545-00	E - 9	90157-05079	E - 11
5GM-2478G-00	D - 5	4YR-26240-01	D - 10	5GM-28356-A0	C - 9	4BP-82370-00	E - 13	5GM-84710-00	E - 9	90159-05028	D - 10
5GM-24780-00	D - 5	4YR-26241-01	D - 10	5GM-2836B-01	E - 2	5GM-82501-11	E - 11	31L-84714-00	E - 9	90167-05003	C - 3
5CG-25160-A0-35	D - 6	33M-26246-00	D - 10	5GM-2836K-02	D - 15	5GM-82509-00	E - 13	5GM-84735-00	E - 9	90167-05079	C - 11
5CG-2517A-00	D - 6	5CG-26280-01	D - 10	5GM-2836L-00	E - 2	4HC-82552-00	E - 11	4HC-84743-00	E - 9		D - 10
4HC-25181-00	D - 6	5CG-26290-01	D - 10	5GM-2836T-00	E - 2	5GH-82560-00	B - 8	4HC-84744-00	E - 9		D - 15
5GM-25319-00	D - 8	5GM-26311-00	D - 10	4HC-2837G-00	E - 7	5GM-82560-00	B - 8	4HC-84770-00	D - 4		E - 3
5GM-25321-00-35	D - 8	5GM-26312-00	D - 10	5GM-2837G-00	D - 15	3LD-82566-50	E - 11	3Y6-85130-02	E - 9	90167-05080	D - 10
5GM-25328-00	D - 8	4HC-2637G-00	D - 12	5GM-2837H-00	D - 15	5GM-82590-10	E - 11	5GM-85752-00	E - 13	90170-06010	E - 10
5GM-25338-00-35	D - 8	5H0-26393-00	D - 10	5GM-28371-00	D - 15	5GM-83310-10	E - 6	4US-85753-00	E - 13	90170-06128	B - 4
29L-25398-00	D - 6	4HC-27111-01	D - 13	5GM-28372-00	D - 15	5GM-83311-00	E - 9	2JG-85757-00	E - 13	90170-16425	B - 3
	D - 8	4HC-27112-00	D - 13	5GM-28376-00	E - 2	5GM-83312-00	E - 6	5GM-85885-00	B - 12	90170-20386	C - 15
29L-25398-10	D - 6	58K-27112-02	D - 13	5GM-28379-00	C - 11	5GM-83313-00	E - 6	5GM-85970-00	D - 6	90170-36279	C - 7
	D - 8	3VR-27114-00	D - 13		C - 12	5GM-83320-10	E - 6	90101-10303	B - 5	90176-06003	D - 4
29L-25398-20	D - 6	4HC-27114-00	D - 13		E - 3	5GM-83322-00	E - 6	90105-10023	C - 9	90176-08026	B - 2
	D - 8	5GM-27311-00	D - 13	5GM-2838B-00	E - 2	32H-83331-00	E - 6	90105-10638	D - 7	90179-05523	E - 2
5GM-25683-00	D - 8	5GM-27414-00	D - 13	5GM-28380-10	E - 2	3GM-83350-01	E - 13		D - 9	90179-14469	C - 6
5CG-2580U-00	D - 7	5GM-27415-00	C - 9	5GM-2839K-00	D - 15	3TB-83371-01	E - 13	90109-060F3	C - 10	90179-25615	C - 14
5GM-2580W-01	D - 9	5GM-27424-00	C - 9	5GM-2839M-00	D - 4	5GM-83371-10	E - 13	90109-06030	C - 3	90183-04027	D - 15
4HC-2582T-00	D - 7		D - 13	5GM-28415-00	D - 15	5GM-83500-00	E - 7	90109-063F1	C - 12	90183-05004	E - 2
5GM-2582W-00	D - 9	5GM-27445-00	C - 9	5GM-28416-00	D - 15	5GM-83500-20	E - 7		D - 4	90183-05042	C - 10
5EB-25828-00	D - 9	5GM-27452-00	C - 9	5GM-28435-00	D - 15	5GM-83509-00	E - 7		D - 5		C - 12
5GM-25828-00	D - 9	5GM-27453-00	D - 13	5GM-2849E-00	D - 13	5GM-83510-00	E - 7		E - 9		D - 4
5CG-2583T-01	D - 11	5GM-27462-00	C - 9	5GM-81410-00	E - 4	5GM-83510-20	E - 7	90109-06577	E - 10		D - 5
5CG-2583T-11	D - 11	5GM-27463-00	D - 14	5GM-81450-00	E - 4	5GM-83511-00	E - 7	90109-066A7	E - 12		D - 10
5GM-2584A-00	D - 11	5GM-27475-00	D - 14	5CG-81677-00	D - 11	1YT-83517-00	E - 7	90109-067E6	B - 10		D - 13
5CG-25844-00	D - 11	5GM-27476-00	D - 14	5GM-81815-00	E - 5	4R0-83517-00	E - 7	90109-082F5	B - 15		E - 2
5GM-25845-00	D - 9	5GM-27481-01	D - 13	4XV-8182A-00	E - 5	3SX-8352K-00	E - 7	90109-083G4	D - 7		E - 9
2KF-25852-01	D - 11	5GM-27482-00	D - 14	3WP-81826-00	E - 5	5GM-8353H-00	E - 7		D - 9	90183-06053	E - 2

NUMERICAL INDEX

PARTNO.	GRID NO.	PARTNO.	GRID NO.	PARTNO.	GRID NO.	PARTNO.	GRID NO.	PARTNO.	GRID NO.	PARTNO.	GRID NO.
90185-10110	D - 13	90387-155F2	C - 13	90467-26131	B - 7	93106-26005	C - 13	95027-06016	E - 13	97707-40512	D - 15
90185-10154	C - 9	90387-1906E	C - 6	90468-08104	B - 13	93109-28043	C - 13	95027-06020	B - 2	97707-50012	C - 11
90185-12072	C - 9	90401-10159	D - 11	90468-12069	B - 3		D - 8	95027-06030	D - 12		C - 12
90185-14163	D - 8	90430-06014	B - 2	90468-18121	D - 5	93210-09165	B - 4	95027-06035	B - 6		D - 2
90185-14166	D - 6		B - 6	90480-01288	C - 12	93210-14104	B - 15	95027-06040	C - 3		D - 14
90201-047R9	C - 6	90430-08119	B - 15	90480-01558	D - 2	93210-15171	B - 5	95027-06070	B - 15		E - 2
90201-05725	C - 11	90430-12213	B - 15	90480-10332	B - 13	93210-16275	B - 6	95027-06100	B - 15	97707-50014	E - 7
90201-06057	D - 4	90445-057G5	D - 15	90480-12237	D - 2		B - 15	95027-06120	B - 2	97707-50016	C - 10
	E - 2	90445-135J8	B - 15	90480-13398	D - 15	93210-16325	C - 4	95027-08040	B - 15		C - 11
90201-06380	B - 14	90446-11303	B - 10		E - 2	93210-19123	C - 3		C - 14		C - 12
90201-08512	B - 6	90450-60001	B - 10	90480-13598	B - 10	93210-27672	C - 2	95607-06100	E - 10		D - 4
	B - 9	90460-15126	D - 10	90480-14323	B - 7	93210-33133	B - 6	95607-06200	B - 14		D - 13
90201-086J0	D - 15	90460-27219	B - 7	90480-16301	B - 8	93210-35520	B - 9	95607-08200	B - 13		D - 15
90201-08609	B - 2	90464-05141	E - 10	90501-10312	E - 10	93210-35537	B - 10	95617-06615	B - 2		E - 6
90201-08784	D - 5	90464-05188	D - 11	90501-14001	B - 7	93210-43713	C - 6	95617-08620	B - 2	97707-50125	B - 10
90201-10118	D - 11	90464-07001	D - 2	90501-18576	B - 9	93210-57634	B - 2	95702-05500	E - 9	97801-05010	B - 11
90201-105A2	C - 9		E - 11	90501-505J6	C - 6	93210-92448	B - 2	95704-06500	E - 2	98501-04012	B - 11
	C - 13	90464-08051	D - 6	90506-18224	D - 13	93211-17733	C - 6	95707-06500	B - 10	98507-05008	D - 10
90201-10591	B - 5	90464-09008	D - 2	90506-20158	D - 13	93306-00006	B - 6		D - 2	98507-05010	D - 5
90201-12166	C - 5	90464-10190	E - 11	90506-26001	D - 13	93306-00518	B - 5	95707-08500	C - 9	98507-05016	E - 13
90201-144M8	C - 6	90464-11003	E - 11	90506-40175	D - 13	93306-20204	B - 5		D - 4	98507-05040	E - 10
90201-156R4	C - 8	90464-11004	B - 14	90560-08326	D - 4	93306-20570	C - 8	95807-06008	B - 7	98507-05045	E - 10
90201-160F6	B - 3	90464-13001	B - 10	91317-05012	E - 4	93306-27205	C - 8	95807-06010	B - 7	98507-05055	E - 10
90201-16242	B - 15	90464-13073	E - 11	91317-06014	B - 5	93306-30201	C - 8		E - 13	98507-06020	C - 3
90201-220J8	D - 8	90464-15192	E - 11		B - 15	93306-30202	D - 6	95807-06012	C - 9	98507-06025	E - 11
90201-232K5	C - 8	90464-15195	D - 10	91317-06016	B - 6	93306-30212	C - 13		C - 15	98706-04012	D - 11
90202-26142	C - 14		E - 11	91317-06020	B - 7		D - 8	95807-06014	B - 14	98901-04006	B - 11
90208-21001	C - 8	90464-16061	E - 12	91317-06025	D - 11	93306-30321	C - 8	95807-06020	B - 13	98907-03008	E - 12
90208-25001	C - 8	90464-20181	E - 11	91317-06030	E - 4	93306-90603	C - 2		D - 11	99001-04600	D - 13
90215-06184	B - 5	90464-20258	D - 10	91317-06035	B - 6	93311-41566	C - 8	95807-06025	C - 13	99001-06600	B - 9
90269-08066	D - 15	90464-23199	D - 12	91317-08016	C - 5	93399-99942	C - 14	95807-08016	C - 9	99001-07600	B - 6
90280-03017	C - 15	90464-25098	E - 13	91317-08030	C - 15	93430-12008	D - 13	95817-06025	E - 5	99001-08600	C - 6
90280-05013	B - 3	90465-13152	D - 10	92014-08016	D - 6	93440-10085	B - 2	95817-08016	B - 15	99009-10400	B - 6
90338-08174	B - 10	90465-14310	D - 6	92017-06012	B - 13	93603-12221	B - 9	95817-08070	C - 13	99009-12400	C - 5
90338-10150	D - 8	90467-07138	B - 14	92017-06025	B - 9	93603-22028	B - 6	95817-10045	C - 9	99009-16400	B - 15
90338-11125	D - 4	90467-08003	C - 12	92907-05600	E - 13		B - 9	95817-10050	B - 13	99009-25400	C - 8
90340-12059	B - 15	90467-09006	B - 14	92907-06200	B - 13	93604-10011	B - 5	95817-12120	C - 9	99246-00080	C - 12
90387-064W3	B - 10	90467-10008	B - 10	92907-06600	C - 3	93900-00022	D - 6	95827-06012	D - 2	99247-00080	C - 12
90387-065J6	D - 15		C - 12		E - 11	93900-00025	D - 8	95827-08030	C - 13	99530-10114	B - 2
90387-06500	D - 4	90467-10038	B - 7	93101-10090	B - 6	94111-1214N	D - 6	95827-10035	C - 13		B - 15
90387-067N5	E - 2		D - 2	93101-14092	C - 3	94111-1215R	D - 6	97007-05012	B - 7		C - 3
90387-0714B	B - 8	90467-11032	B - 10	93101-28139	C - 6	94113-1204P	D - 8	97007-06012	B - 5	99530-14016	B - 2
90387-1006J	B - 15	90467-12053	D - 2	93102-22014	D - 6	94113-1215X	D - 8	97702-40912	E - 8		
90387-1508E	D - 6	90467-13064	B - 2		D - 8	94581-63104	B - 5	97706-40114	E - 9		
90387-151R0	D - 6	90467-14117	B - 13	93102-25299	C - 8	94701-00333	B - 2	97707-30512	E - 7		
90387-153N7	D - 6	90467-16195	B - 14	93102-30284	B - 15	95024-06010	B - 7	97707-40010	D - 13		
90387-154E1	C - 13	90467-22100	B - 7	93102-32298	C - 8	95027-06008	E - 11	97707-40016	E - 7		
90387-15423	C - 13	90467-23177	B - 7	93104-41119	C - 6	95027-06012	D - 2	97707-40512	D - 13		

CONTENTS

ENGINE

CYLINDER	B2
CRANKSHAFT. PISTON	B3
VALVE	B4
CAMSHAFT. CHAIN	B5
WATER PUMP	B6
RADIATOR. HOSE	B7
OIL PUMP	B9
INTAKE	B10
CARBURETOR	B11
EXHAUST	B13
CRANKCASE	B15
CRANKCASE COVER 1	C3
STARTER	C5
CLUTCH	C6
TRANSMISSION	C8

CHASSIS

FRAME	C9
FENDER	C10
SIDE COVER	C11
REAR ARM. SUSPENSION	C13
STEERING	C14
FUEL TANK	D2
SEAT	D4
FRONT WHEEL	D6
FRONT BRAKE CALIPER	D7
REAR WHEEL	D8
REAR BRAKE CALIPER	D9
STEERING HANDLE. CABLE	D10

FRONT MASTER CYLINDER	D11
STAND. FOOTREST	D13
LEG SHIELD	D15
GENERATOR	E4
STARTING MOTOR	E5
FLASHER LIGHT	E6
METER	E7
HEADLIGHT	E8
TAILLIGHT	E9
HANDLE SWITCH. LEVER	E10
ELECTRICAL 1	E11
ELECTRICAL 2	E13

INDEX

NUMERICAL INDEX	M1
-----------------------	----