

YAMAHA MBK 

YQ50

'97

5BS-AE2

**SERVICE
MANUAL**



YQ50
SERVICE MANUAL
© 1997 by MBK INDUSTRIE
2st Edition, November 1997
All rights reserved. Any
reprinting or unauthorized use
without the written
permission of MBK INDUSTRIE
is expressly prohibited.

NOTICE

This manual was written by the MBK INDUSTRIE primarily for use by YAMAHA and MBK dealers and their qualified mechanics. It is not possible to put an entire mechanic's education into one manual, so it is assumed that persons using this book to perform maintenance and repairs on YAMAHA and MBK scooters have a basic understanding of the mechanical concepts and procedures inherent in scooter repair technology. Without such knowledge, attempted repairs or service to this model may render it unfit to use and/or unsafe.

MBK INDUSTRIE is continually striving to improve all models manufactured. Modifications and significant changes in specifications or procedures will be forwarded to all Authorized YAMAHA and MBK dealers and will, where applicable, appear in future editions of this manual.

DOCUMENTATION TECHNIQUE
MBK INDUSTRIE

PARTICULARLY IMPORTANT INFORMATION

This material is distinguished by the following notation :



The safety Alert Symbol means ATTENTION! BECOME ALERT! YOUR SAFETY IS INVOLVED!



Failure to follow WARNING instructions could result in severe injury or death to the scooter operator, a bystander, or a person inspecting or repairing the scooter.

CAUTION:

A CAUTION indicates special precautions that must be taken to avoid damage to the scooter.

NOTE:

A NOTE provides key information to make procedures easier or clearer.

HOW TO USE THIS MANUAL

CONSTRUCTION OF THIS MANUAL

This manual consists of chapters for the main categories of subjects. (See «illustrated symbols».)

- 1st title ① This is a chapter with its symbol on the upper right of each page.
- 2nd title ② This title appears on the upper of each page on the left of the chapter symbol. (For the chapter «Periodic inspection and adjustment» the 3rd title appears.)
- 3rd title ③ This is a final title.

MANUAL FORMAT

All of the procedures in this manual are organized in a sequential, step-by-step format. The information has been compiled to provide the mechanic with an easy to read, handy reference that contains comprehensive explanations of all disassembly, repair, assembly, and inspections.

A set of particularly important procedure ④ is placed between a line of asterisks " * " with each step preceded by " • ".

IMPORTANT FEATURES





















- Data and a special tools are framed in a box preceded by a relevant symbol ⑤.
- An encircled numeral ⑥ indicates a part name, and an encircled alphabetical letter data for an alignment mark ⑦, the others being indicated by an alphabetical letter in a box ⑧.
- A condition of a faulty component will precede an arrow symbol and the course of action required the symbol ⑨.

EXPLODED DIAGRAM

Each chapter provides exploded diagrams are before each disassembly section for ease in identifying correct disassembly and assembly procedures.

The diagram illustrates two pages from a manual, with numbered callouts 1 through 9 pointing to specific features:

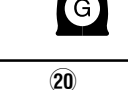
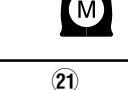
- Page 1 (Left):**
 - ①: Chapter title "INSPECTION AND REPAIR" and engine symbol "ENG".
 - ②: Section title "INSPECTION AND REPAIR CYLINDER HEAD".
 - ③: Illustration of a hand using a scraper on a cylinder head.
 - ④: Illustration of a hand measuring cylinder head warpage with a straight edge and gauge.
 - ⑤: Box containing "Warpage limit: 0.02 mm (0.001 in)".
 - ⑥: Part name "CYLINDER HEAD".
 - ⑦: Alignment mark "A".
 - ⑧: Box containing "Chain lube: Yamaha chain lube or equivalent".
- Page 2 (Right):**
 - ①: Chapter title "FRONT FORK" and motorcycle symbol "CHAS".
 - ②: Section title "INSPECTION".
 - ③: Illustration of a hand inspecting a fork tube.
 - ④: Illustration of a hand measuring a fork spring.
 - ⑤: Box containing "Fork spring free length: 410.5 mm (16.1 in) Minimum free length: 410 mm (16.1 in)".
 - ⑥: Part name "FRONT FORK".
 - ⑦: Alignment mark "B".
 - ⑧: Box containing "Chain lube: Yamaha chain lube or equivalent".

① GEN INFO 	② SPEC 	
③ INSP ADJ 	④ ENG 	
⑤ CARB 	⑥ CHAS 	
⑦ ELEC 	⑧ TRBL SHTG 	
⑨ 	⑩ 	
⑪ 	⑫ 	
⑬ 	⑭ 	
⑮ 		
⑯ 	⑰ 	⑱ 
⑲ 	⑳ 	㉑ 
㉒ 	㉓ New	

ILLUSTRATED SYMBOLS (REFER TO THE ILLUSTRATION)

Illustrated symbols ① to ② are designed as thumb tabs to indicate the chapter's number and content.

- ① General information
- ② Specifications
- ③ Periodic inspection and adjustment
- ④ Engine
- ⑤ Carburetion
- ⑥ Chassis
- ⑦ Electrical
- ⑧ Troubleshooting









Illustrated symbols ⑨ to ⑮ are used to identify the specifications appearing in the text.

- ⑨ Filling fluid
- ⑩ Lubricant
- ⑪ Special tool
- ⑫ Tightening
- ⑬ Wear limit, clearance
- ⑭ Engine speed
- ⑮ Ω , V, A

Illustrated symbols ⑯ to ㉓ in the exploded diagram indicate grade of lubricant and location of lubrication point.

- ⑯ Apply engine oil
- ⑰ Apply gear oil
- ⑱ Apply molybdenum disulfide oil
- ⑲ Apply wheel bearing grease
- ⑳ Apply lightweight lithium-soap base grease
- ㉑ Apply molybdenum disulfide grease
- ㉒ Apply locking agent (THREADLOCK®)
- ㉓ Use new one

INDEX

GENERAL INFORMATION	
	GEN INFO 1
SPECIFICATIONS	
	SPEC 2
PERIODIC INSPECTION AND ADJUSTMENT	
	INSP ADJ 3
ENGINE OVERHAUL	
	ENG 4
COOLING SYSTEM	
	ENG 5
CARBURETION	
	CARB 6
CHASSIS	
	CHAS 7
ELECTRICAL	
	ELEC 8
TROUBLESHOOTING	?
	TRBL SHTG 9

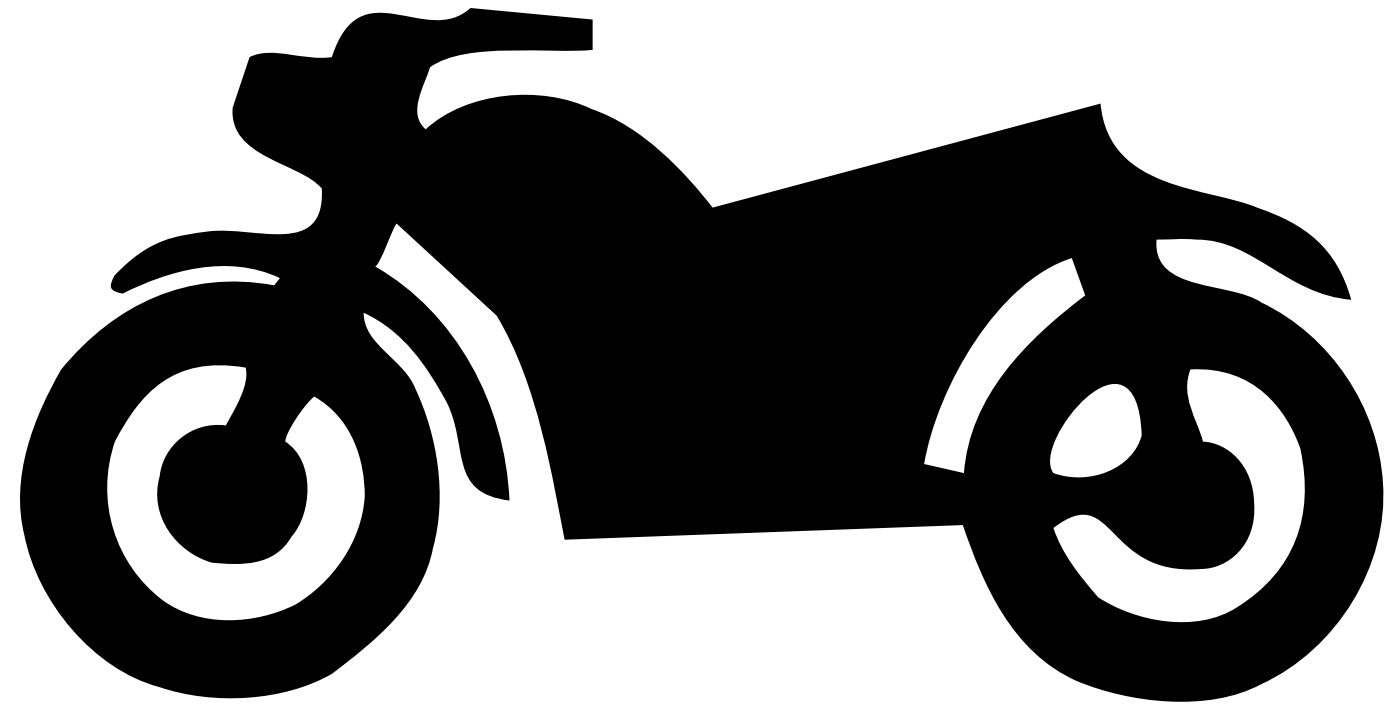

**GEN
INFO**

1

CHAPTER 1. GENERAL INFORMATION

SCOOTER IDENTIFICATION	1-1
VEHICLE IDENTIFICATION NUMBER	1-1
ENGINE SERIAL NUMBER	1-1
IMPORTANT INFORMATION	1-2
ALL REPLACEMENT PARTS	1-2
GASKETS, OIL SEALS, AND O-RINGS	1-2
LOCK WASHERS/PLATES AND COTTER PINS	1-2
BEARINGS AND OIL SEALS	1-2
CIRCLIPS	1-3
SPECIAL TOOLS	1-4

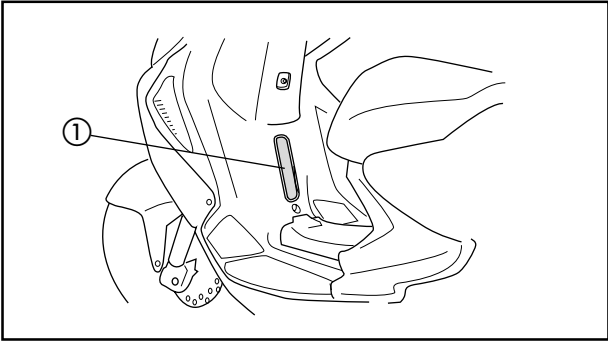

GENERAL INFORMATION

SCOOTER IDENTIFICATION

VEHICLE IDENTIFICATION NUMBER

The vehicle identification number ① is stamped into the frame.

NOTE: _____
The vehicle identification number is used to identify your scooter and may be used to register your scooter with the licensing authority in your state.

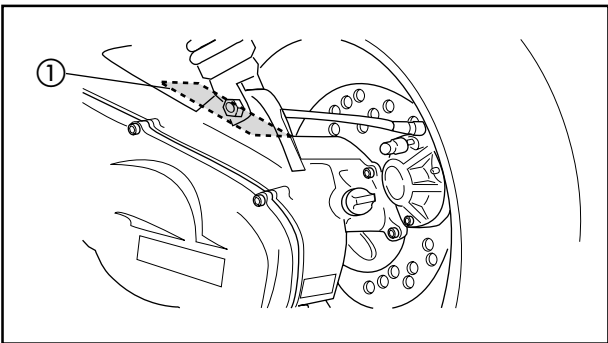

ENGINE SERIAL NUMBER

The engine serial number ① is stamped into the crankcase.

NOTE: _____
The first three digits of these numbers are for model identifications; the remaining digits are the unit production number.

NOTE: _____
Designs and specifications are subject to change without notice.

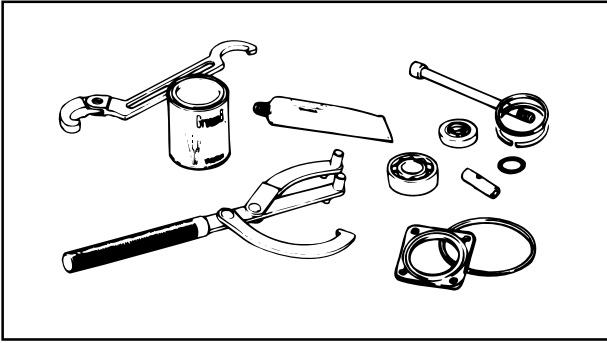

IMPORTANT INFORMATION

ALL REPLACEMENT PARTS

1. Use only genuine parts for all replacements. Use oil and/or grease recommended by MBK/YAMAHA for assembly and adjustment. Other brands may be similar in function and appearance, but inferior in quality.

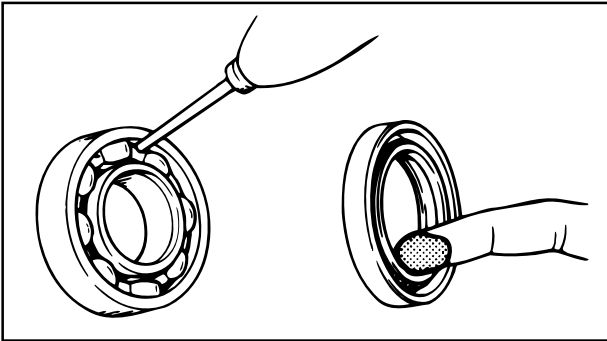

GASKETS, OIL SEALS, AND O-RINGS

1. All gaskets, seals and O-rings should be replaced when an engine is overhauled. All gaskets surfaces, oil seal lips and O-rings must be cleaned.
2. Properly oil all mating parts and bearing during reassembly. Apply grease to the oil seal lips.

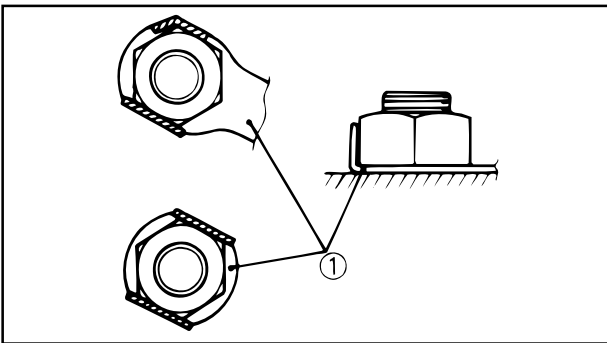

LOCK WASHERS/PLATES AND COTTER PINS

1. All lock washers/plates ① and cotter pins must be replaced when they are removed. Lock tab(s) should be bent along the bolt or nut flat(s) after the bolt or nut has been properly tightened.

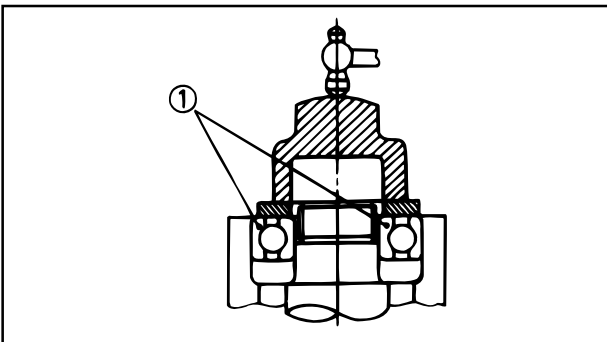

BEARINGS AND OIL SEALS

1. Install the bearing(s) ① and oil seal(s) ② with their manufacturer's marks or numbers facing outward. (In other words, the stamped letters must be on the side exposed to view.) When installing oil seal(s), apply a light coating of lightweight lithium base grease to the seal lip(s). Oil the bearings liberally when installing.

CAUTION :

Do not use compressed air to spin the bearings dry. This causes damage to the bearing surfaces.

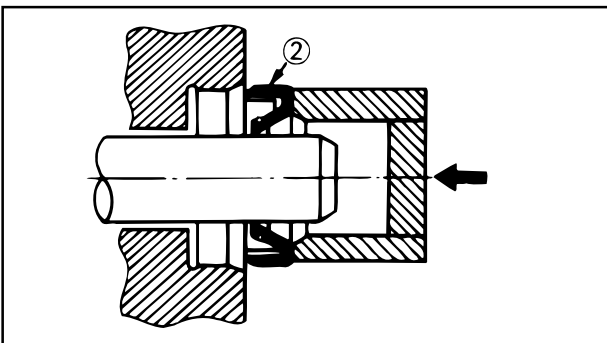

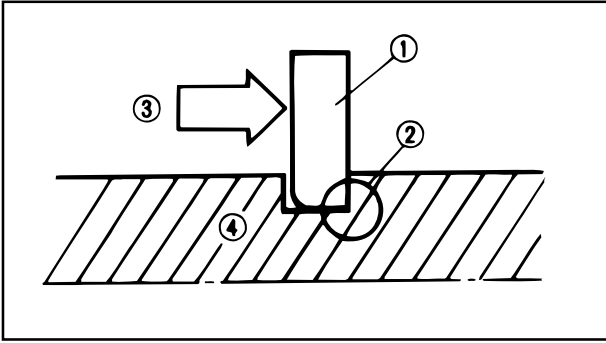

CIRCLIPS

1. All circlips should be inspected carefully before reassembly. Always replace piston pin clips once they have been removed. Replace bent circlips. When installing a circlip ① make sure that the sharp edge ② is positioned opposite to the thrust ③ it receives. See the sectional view.

④ Shaft

EB102000

SPECIAL TOOLS

The following special tools are necessary for complete and accurate tune-up and assembly.

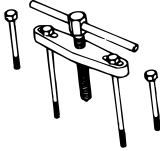
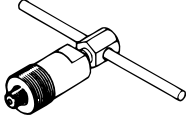
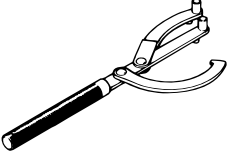
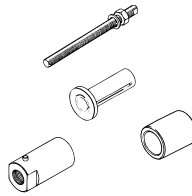
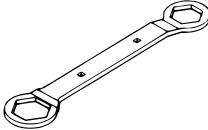
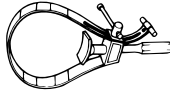
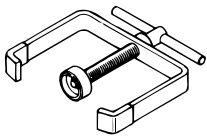

Use only the appropriate special tools; this will help prevent damage caused by the use of inappropriate tools or improvised techniques.

When placing an order, refer to the list provided below to avoid any mistakes.

Tool N°	Tool name/usage	Illustration
90890-01135	<p>Crankcase separating tool</p> <p>This tool is used to separate the crankcase and remove the crankshaft.</p>	
90890-01189	<p>Flywheel puller</p> <p>This tool is used to remove the flywheel magneto.</p>	
90890-01235	<p>Rotor holding tool</p> <p>This tool is used to remove the flywheel magneto.</p>	
<p>90890-01274 90890-01275 90890-01277 90890-01411</p>	<p>Crankshaft installer set.</p> <p>These tools are used to install the crankshaft.</p>	
90890-01348	<p>Locknut wrench</p> <p>This tool is used when removing or installing the secondary sheave nut.</p>	
90890-01701	<p>Sheave holder</p> <p>This tool is used to hold the secondary sheave when removing or installing the nut.</p>	
90890-01337	<p>Clutch spring holder.</p> <p>This tool is used for compressing the spring of the secondary sheave when removing the nut.</p>	

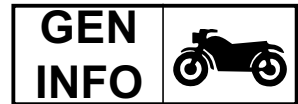
SPECIAL TOOLS

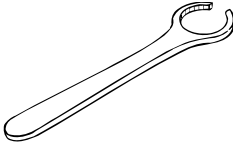
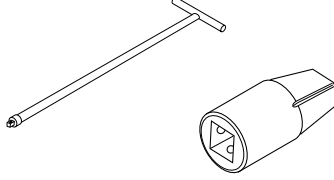
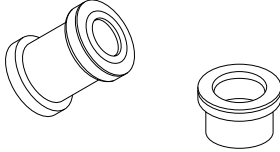

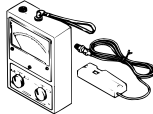
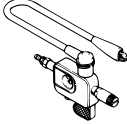
Tool N°	Tool name/usage	Illustration
9079Q-02218	<p>Ring nut wrench.</p> <p>This tool is used to loosen and tighten the steering ring nut.</p>	
90890-01326 90890-1294	<p>T-handle Damper rod holder</p> <p>These tools are used for holding the damper rod holder when removing or installing the damper rod holder.</p>	
90890-01184 90890-01186	<p>Fork seal driver weight. Fork seal driver attachment (ø27)</p> <p>These tools are used when installing the fork seals.</p>	
90890-03112	<p>Pocket Tester</p> <p>This instrument is invaluable for checking the electrical system.</p>	
90890-03113	<p>Engine tachometer.</p> <p>This tool is needed for detecting the engine rpm.</p>	
90890-06754	<p>Ignition checker.</p> <p>This instrument is necessary for checking the ignition system components.</p>	

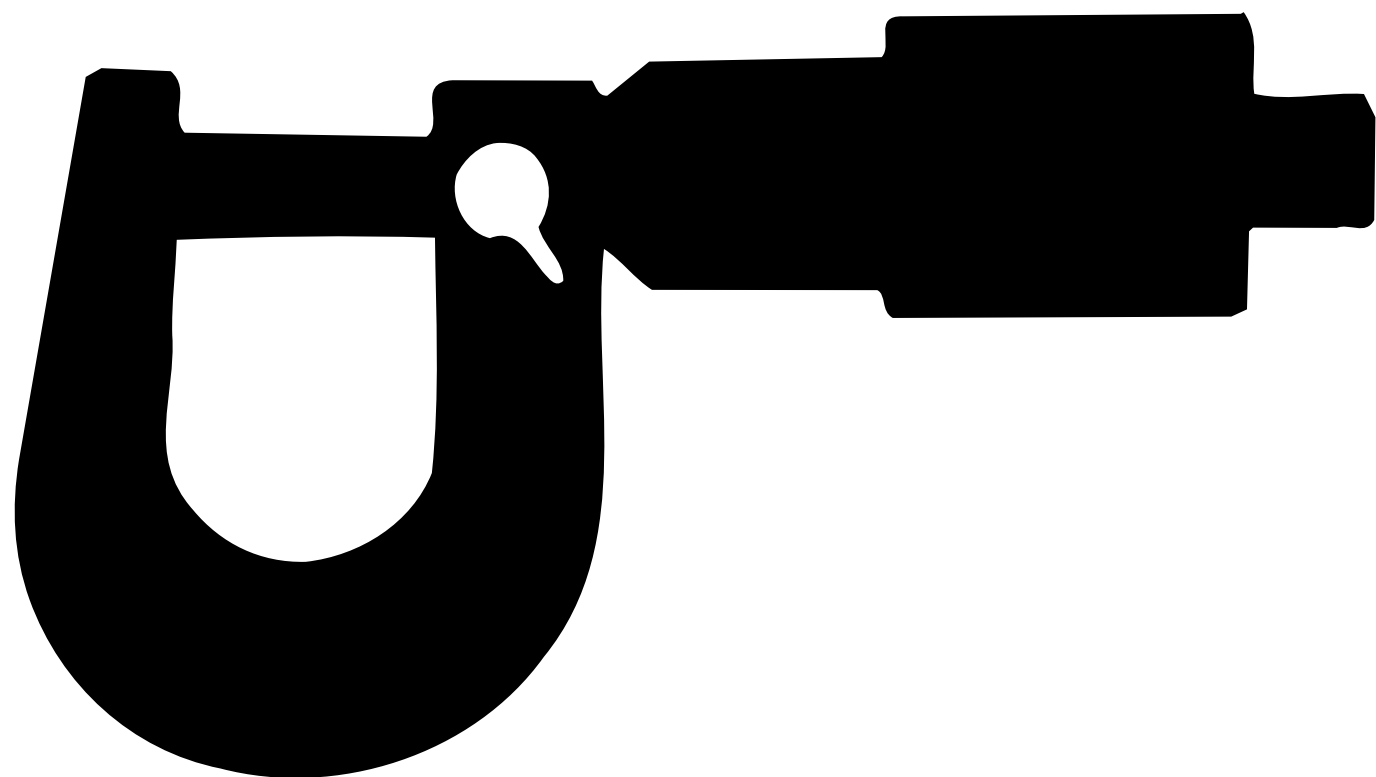

SPEC

2

CHAPTER 2. SPECIFICATIONS

GENERAL SPECIFICATIONS	2-1
MAINTENANCE SPECIFICATIONS	2-4
ENGINE	2-4
CHASSIS	2-6
ELECTRICAL	2-7
CABLE ROUTING	2-8



SPECIFICATIONS

GENERAL SPECIFICATIONS

Model	YQ50
Dimensions:	
Overall length	1.743 mm
Overall width	690 mm
Overall height	1.170mm
Seat height	828 mm
Wheelbase	1.256 mm
Minimum ground clearance	185 mm
Basic weight:	
With oil and full fuel tank	97 kg
Minimum turning radius :	1.800 mm
Engine:	
Type	Liquid-cooled 2-stroke, gasoline torque induction.
Cylinder arrangement	Single cylinder, horizontal
Displacement	49 cm ³
Bore x stroke	40 x 39.2 mm
Compression ratio	7.9 : 1 (F)(B)(P)(E)(I) 8 : 1 (D)(NL)(CHE)
Starting system	Electric and kick starter
Lubrication system:	Separate lubrication (Yamaha Autolube)
Oil type or grade:	
Engine oil:	Semi-synthetic, in accordance with the API TC TSC 3 Standard.
Transmission oil	SAE 10W30 type SE motor oil
Oil capacity:	
Transmission oil:	
Periodic oil change	0.11 L
Total amount	0.13 L
Radiator capacity	
Total amount (Including all routes)	1.2 L
Air filter:	Wet type element
Fuel:	
Type	Regular unleaded gasoline with a research octane number of 91 or higher.
Tank capacity	7.0 L

GENERAL SPECIFICATIONS

SPEC



Model	YQ50																											
Carburetor: Type/Manufacturer	PHBN12HS / DELL'ORTO																											
Spark plug: Type/Manufacturer Gap	BR8HS/NGK 0.5 ~ 0.7 mm																											
Clutch type:	Dry, centrifugal automatic																											
Transmission: Primary reduction system Primary reduction ratio Secondary reduction system Secondary reduction ratio Transmission Operation	Helical gear 52/13 (4.000) Spur gear 43/14 (3.071) V-belt Automatic																											
Chassis: Frame type Caster angle Trail	Steel tube underbone 27° 90 mm																											
Tire: Type Size Manufacturer/type Tire pressure (cold tire)	<table style="width: 100%; border-collapse: collapse;"> <tr> <td style="width: 30%;"></td> <td style="width: 15%; text-align: center;">Front</td> <td style="width: 55%;">Tubeless</td> </tr> <tr> <td></td> <td style="text-align: center;">Rear</td> <td>130/60-13</td> </tr> <tr> <td></td> <td style="text-align: center;">Front</td> <td>140/60-13</td> </tr> <tr> <td></td> <td style="text-align: center;">Rear</td> <td>PIRELLI / SL36</td> </tr> <tr> <td></td> <td style="text-align: center;">Rear</td> <td>MICHELIN / BOPPER</td> </tr> <tr> <td></td> <td style="text-align: center;">Front</td> <td>PIRELLI / SL36</td> </tr> <tr> <td></td> <td style="text-align: center;">Rear</td> <td>MICHELIN / BOPPER</td> </tr> <tr> <td></td> <td style="text-align: center;">Front</td> <td>150 kPa (1.50 kg/cm²)</td> </tr> <tr> <td></td> <td style="text-align: center;">Rear</td> <td>150 kPa (1.50 kg/cm²)</td> </tr> </table>		Front	Tubeless		Rear	130/60-13		Front	140/60-13		Rear	PIRELLI / SL36		Rear	MICHELIN / BOPPER		Front	PIRELLI / SL36		Rear	MICHELIN / BOPPER		Front	150 kPa (1.50 kg/cm ²)		Rear	150 kPa (1.50 kg/cm ²)
	Front	Tubeless																										
	Rear	130/60-13																										
	Front	140/60-13																										
	Rear	PIRELLI / SL36																										
	Rear	MICHELIN / BOPPER																										
	Front	PIRELLI / SL36																										
	Rear	MICHELIN / BOPPER																										
	Front	150 kPa (1.50 kg/cm ²)																										
	Rear	150 kPa (1.50 kg/cm ²)																										
Brake: Front brake type Operation Rear brake type Operation	Disc brake Right hand operation Disk brake Left hand operation																											
Suspension: Front Rear	Telescopic fork Unit swing																											
Shock absorber: Front Rear	Coil spring/Oil damper Coil spring/Oil damper																											
Wheel travel: Front wheel travel Rear wheel travel	80 mm 72 mm																											

MAINTENANCE SPECIFICATIONS

ENGINE

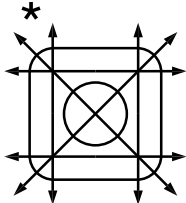
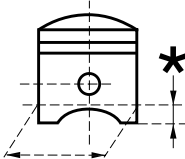
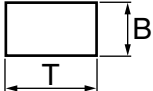
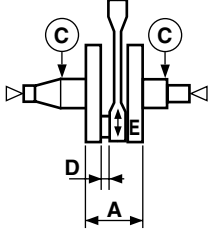
Model	YQ50
<p>Cylinder head: Warp limit</p> 	<p>0.02 mm * Lines indicate straight edge measurements.</p>
<p>Cylinder: Bore size <Limit> Taper limit</p>	<p>39.993 ~ 40.012 mm <40.1 mm> 0.05 mm</p>
<p>Piston: Piston size Measuring point *</p>  <p>Piston clearance <Limit> Piston pin bore size</p>	<p>39.957 ~ 39.977 mm 5 mm 0.029 ~ 0.042 mm <0.1 mm> 10.004 ~ 10.019 mm</p>
<p>Piston pin: Outside diameter</p>	<p>9.996 ~ 10.000 mm</p>
<p>Piston ring: Sectional sketch (BxT)/Type: Top ring 2nd ring End gap (installed): Top ring 2nd ring Side clearance (installed): Top ring 2nd ring</p> 	<p>1.5 ~ 1.8 mm 1.5 ~ 1.8 mm 0.15 ~ 0.35 mm 0.15 ~ 0.35 mm 0.03 ~ 0.05 mm 0.03 ~ 0.05 mm</p>
<p>Crankshaft:</p>  <p>Crank width "A" Runout limit "C" Connecting rod big end side clearance "D" Big end radial clearance "E"</p>	<p>37.90 ~ 37.95 mm 0.03 mm 0.2 ~ 0.5 mm 0.004 ~ 0.017 mm</p>

MAINTENANCE SPECIFICATIONS

SPEC



Model	YQ50
Automatic centrifugal clutch: Clutch shoe thickness <Wear limit> Clutch shoe spring free length Clutch housing inside diameter <Wear limit> Clutch-in revolution Clutch-stall revolution	2.0 mm <1.0 mm> 29.9 mm 107.0 mm 107.4 mm 3.950 ~ 4.450 r.p.m. 6.900 ~ 7.700 r.p.m.
V-belt: Width <Wear limit>	16.5 mm <15.7 mm>
Transmission: Main axle runout limit Drive axle runout limit	0.08 mm 0.08 mm
Kick starter: Type Kick clip tension	Ratchet type 0.15 ~ 0.25 kg
Carburetor: I.D mark Main jet (M.J) Main air jet (M.A.J) Jet needle (J.N) Needle jet (N.J) Cutaway (C.A) Pilot jet (P.J) Bypass 1 (B.P.1) Air screw (A.S) Valve seat size (V.S) Starter jet (G.S.1) Engine idle speed	DELLORTO PHBN 12 HS #86 (F)(B)(P)(I)(E) #85 (CHE) #74 (NL) ø1.5 A21 - 2/5 (F)(B)(P)(I)(E) A12 - 3/5 (D)(CHE) A20 - 3/5 (NL) 210 GA (F)(B)(P)(I)(E)(D) 209 GA (CHE) 208 GA (NL) 3.0 4.0 (CHE) #36 #34 (CHE) 0.8 1 3/8 ± 1/8 (F)(B)(P)(I)(E) 1 3/4 ± 1/8 (D) 1 5/8 ± 1/8 (NL) 2 ± 1/8 (CHE) 1.2 #45 1600 ~ 2000 rpm
Reed valve: Valve stopper height Reed valve clearance	6.0 ~ 6.4 mm Less than 0.2 mm
Lubrication system: Stroke Bore	Autolube pump 2.62 mm (F)(B)(P)(I)(E) 2.5 mm (D)(NL)(CHE) 0.5 mm

MAINTENANCE SPECIFICATIONS

SPEC



CHASSIS

Model	YQ50
Steering system: Steering bearing type No/Size of steel balls: <div style="text-align: right; margin-right: 20px;"> Upper Lower </div>	Ball bearing 15 pcs (4.75 mm) 15 pcs (4.75 mm)
Front suspension: Front fork travel Spring rate (K1) Stroke (K1) Optional spring	80 mm 5.7 N/mm 0 ~ 80 mm No
Rear suspension: Shock absorber travel Spring free length Spring fitting length Spring rate (K1) <div style="text-align: right; margin-right: 20px;">(K2)</div> Stroke (K1) <div style="text-align: right; margin-right: 20px;">(K2)</div> Optional spring	60 mm 234 mm 199.5 mm 28 N/mm 35 mm 0 ~ 92 mm 92 ~ 115 mm No
Wheels: Front wheel type Rear wheel type Front wheel size/Material Front wheel size/Material	Cast wheel Cast wheel MT 3.00 x13 / Aluminium MT 3.50 x13 / Aluminium
Rim runout limit: Front Rear	1.0 mm 1.0 mm
Front disc brake: Type Diameter and thickness Pad thickness <Wear limit> Master cylinder inside diameter Caliper cylinder inside diameter Brake fluid type	Single disc 190 x 3.5 mm 4.5 mm <2.0 mm> 11 mm 30 mm DOT# 3 or DOT#4
Rear disk brake: Type Diameter and thickness Pad thickness <Wear limit> Master cylinder inside diameter Caliper cylinder inside diameter Brake fluid type	Single disc 190 x 3.5 mm 4.5 mm <2.0 mm> 11 mm 30 mm DOT# 3 or DOT#4
Front brake lever freeplay: Rear brake lever freeplay:	10 ~ 20 mm 10 ~ 20 mm

MAINTENANCE SPECIFICATIONS

SPEC



ELECTRICAL

Model	YQ50
Voltage:	12 V
Ignition system: Ignition timing (B.T.D.C.)	14° at 5.000 r/min
CDI: Pickup coil resistance (color) Source coil resistance (color)	400 ~ 600 Ω at 20°C (68°F) (White/Red-Black) 640 ~ 960 Ω at 20°C (68°F) (Black/Red-Black)
Ignition coil: Minimum spark length Primary coil resistance Secondary coil resistance	6 mm 0.56 ~ 0.84 Ω at 20°C (68°F) 5.68 ~ 8.52 Ωk at 20°C (68°F)
Spark plug cap: Resistance	5 kΩ at 20°C (68°F)
CDI Magneto: Lighting coil resistance Lighting coil resistance	0.32 ~ 0.48 Ω at 20°C (68°F)(Yellow/Red-Black) 0.48 ~ 0.72 Ω at 20°C (68°F)(White-Black)
Voltage regulator/Rectifier: Type No load regulated voltage Capacity Withstand voltage	Semi-conductor, short-circuit type 13 ~ 14 V 8 A 600 V
Battery: Specific gravity	1.280
Starter motor: Out put Armature coil resistance Brush overall length <Wear limit> Brush spring pressure Commutator diameter <Wear limit> Mica undercut (depth)	0.14 kW 0.06 ~ 0.08 Ω at 20°C (68°F) 3.9 mm 0.9 mm 563 ~ 844 g 15.8 mm 14.8 mm 1.15 mm
Starter relay: Amperage rating Coil winding resistance	20 A 54 ~ 66 Ω at 20°C (68°F)
Horn: Maximum amperage	2.5 A
Flasher relay: Type Self canceling device Flasher frequency	Condenser type No 80 ~ 160 cycle/min
Fuel gauge: Sender unit resistance (full) (empty)	1.5 ~ 7.5 Ω 90 ~ 100 Ω
Contact braker: Main fuse	7,5 A x 1

CABLE ROUTING

- ① Handlebar end grip
- ② Right handlebar switch
- ③ Left handlebar switch
- ④ Handlebar
- ⑤ Flasher harness
- ⑥ Right handlebar grip
- ⑦ Wireharness
- ⑧ Wireharness cord
- ⑨ Starter (choke) cable
- ⑩ Front handlebar cover
- ⑪ Speedometer case
- ⑫ Speedometer cable
- ⑬ Front brake hose
- ⑭ Rear brake hose

- A** Push the end grip against the handlebar and tighten to 0.6 ~ 0.8 m.kg.
- B** Tighten the front screw first.
- C** Apply the left switch handle against the handlebar.
- D** Hole for the front flasher harness.
- E** Install the right handlebar grip in regard to the right handlebar switch.
- F** Group the connexions here.
- G** Attach the wiring harness cord on the handlebar bracket.
- H** Pass the starter (choke) through the handle cover.
- I** Glue the left handlebar grip.
- J** Cut the band at 5 mm of his end.
- K** Clip the front handlebar cover on the speedometer case.
- L** Front steering assembly:
 - Tighten the ring nut in order to eliminate all play.
 - Take care of installing the special washer on the steering ball race: teeth against teeth.

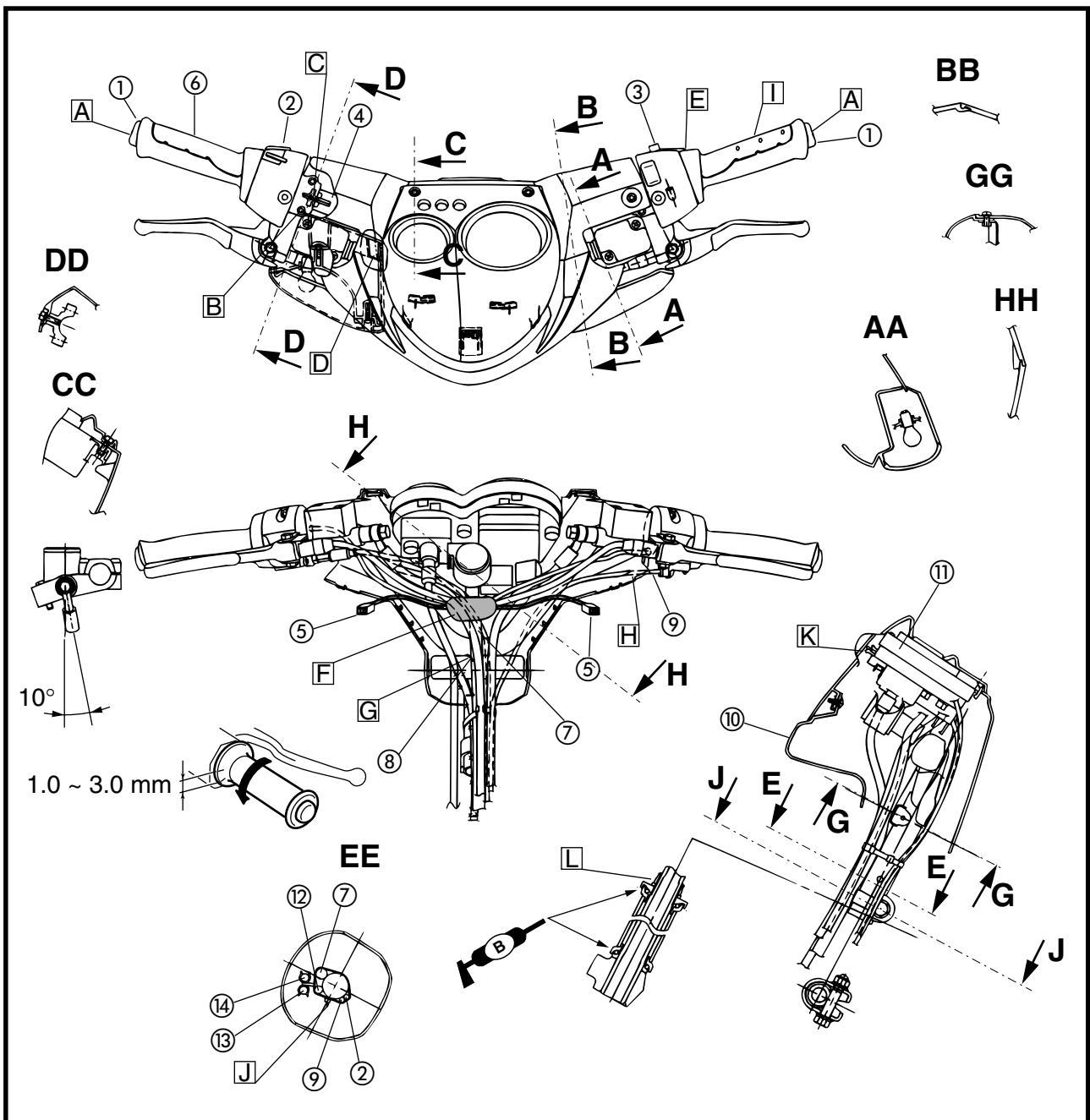



CABLE ROUTING

- ① Fuel sender
- ② Fuel tank
- ③ Fuel overflow pipe
- ④ Fuel cock
- ⑤ Pipe bracket
- ⑥ Frame
- ⑦ Trunk
- ⑧ Carburetor drain hose
- ⑨ Fuel pipe
- ⑩ Suction pipe
- ⑪ Bands

- A Insert the fuel sender completely.
- B Turn the fuel sender so that the cable points toward.
- C Pass the fuel lines above the rear brake hose.
- D Pass the fuel overflow pipe in the trunk slot.
- E Push the fuel cock (without turning it) completely in the tank and screw the collar.
- F Install the hoses facing to the inside of the frame.
- G Pass the fuel tank pipe overflow and carburetor drain pipes in the bracket.
- H Attach the fuel and suction pipes in the bands.
- I Pass the fuel overflow pipe inside the frame.
- J Install the fuel pipes without lubricating them.

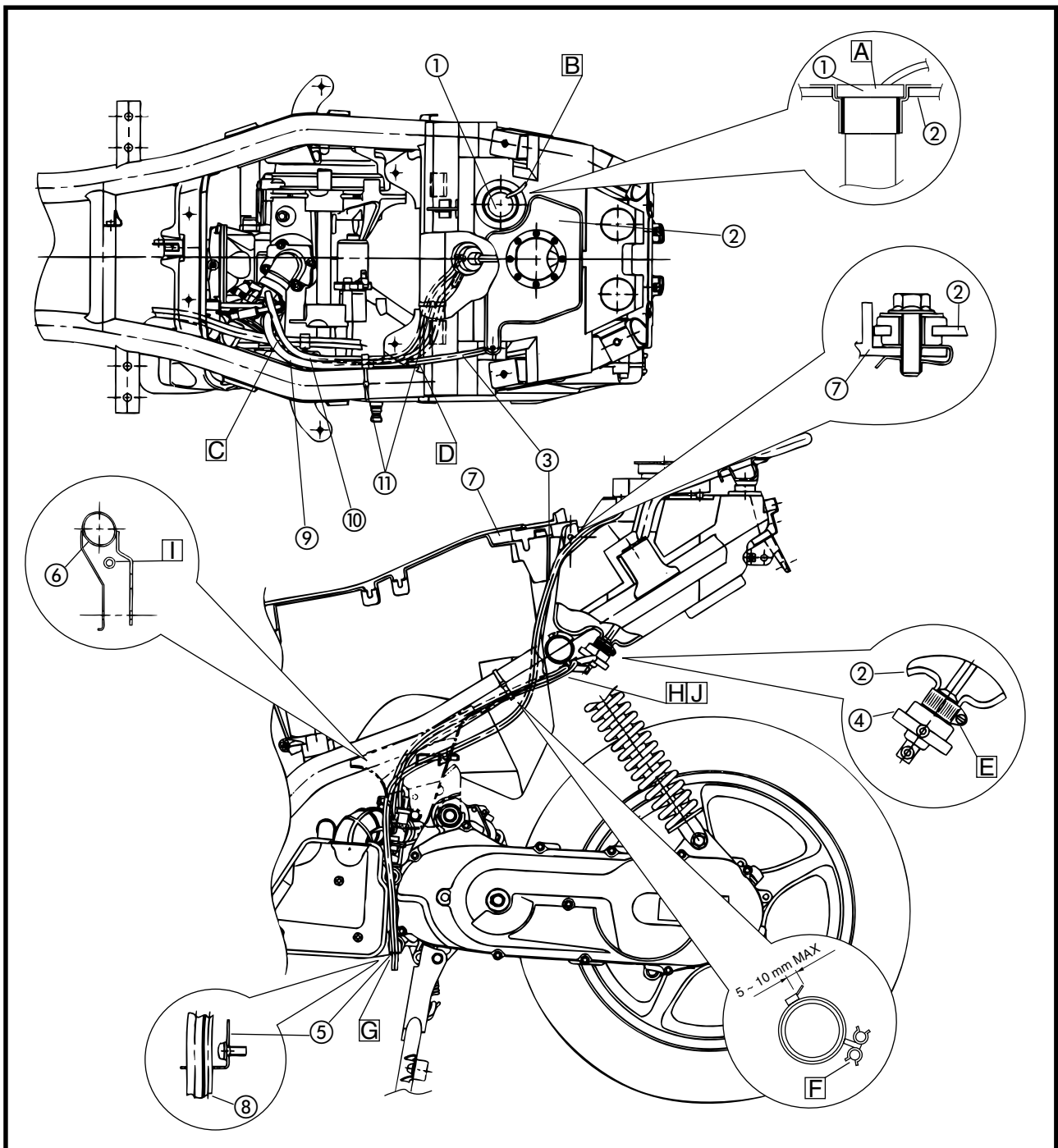

CABLE ROUTING

SPEC



- ① Seat lock
- ② Starter motor
- ③ Ignition coil
- ④ Battery
- ⑤ Starter relay
- ⑥ Fuse housing
- ⑦ Rear brake hose
- ⑧ Fuel sender
- ⑨ CDI unit
- ⑩ Oil lever gauge
- ⑪ Main switch
- ⑫ Rectifier/regulator
- ⑬ Head light
- ⑭ Water hose
- ⑮ Water temperature sender
- ⑯ Seat lock cable adjuster

- A Set the seat lock adjuster so that there is a gap between 8 ~ 9 mm at the seat lock aperture.
- B Install the starter relay on the footrest board.
- C Group the connections here.
- D Turn the connectors towards.
- E Push the wiring inside.
- F Pass the wiring harness through the footrest board.
- G Turn the ground lead one turn around the starter motor leads.
- H The water temperature sender lead must go straight to the wiring harness.
- I Put one drop of Loctite 542 on the tread before installing the water temperature sender.
- J Install the head light protector correctly.
- K Pass the main switch lead between the rectifier/regulator and the steering head pipe.

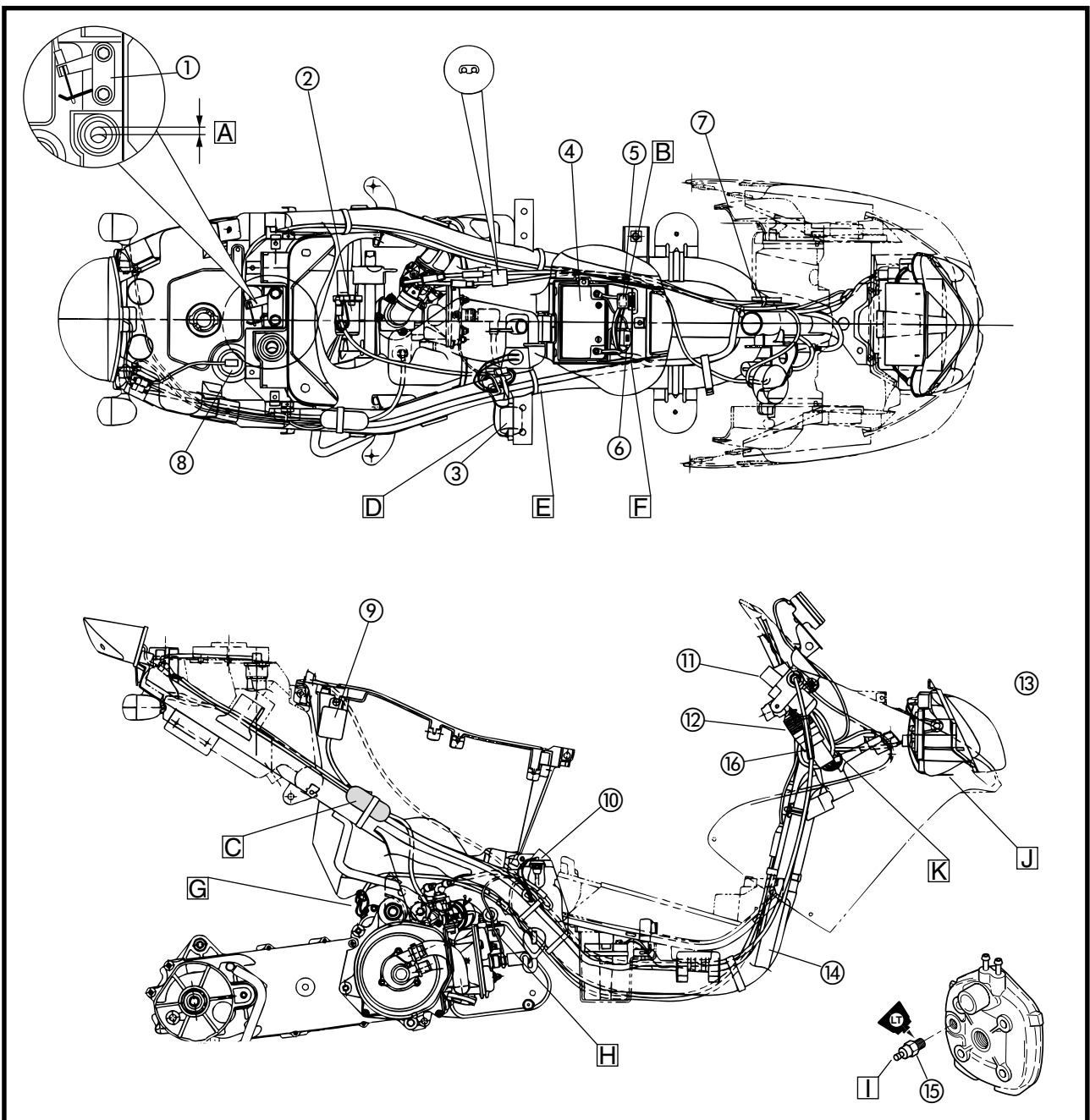

CABLE ROUTING



- ① Wiring harness
- ② Resistor
- ③ Horn
- ④ Front brake hose
- ⑤ Speedometer cable
- ⑥ Radiator
- ⑦ Water tank
- ⑧ Clamps
- ⑩ Frame

- A Install the wiring harness in the middle of the frame.
- B Set the resistor at 45°0/+30' on the frame bracket.
- C Clip the front brake hose on the front fork bracket.
- D Install the 8 clamps just beside the marks at the end side of the hoses.

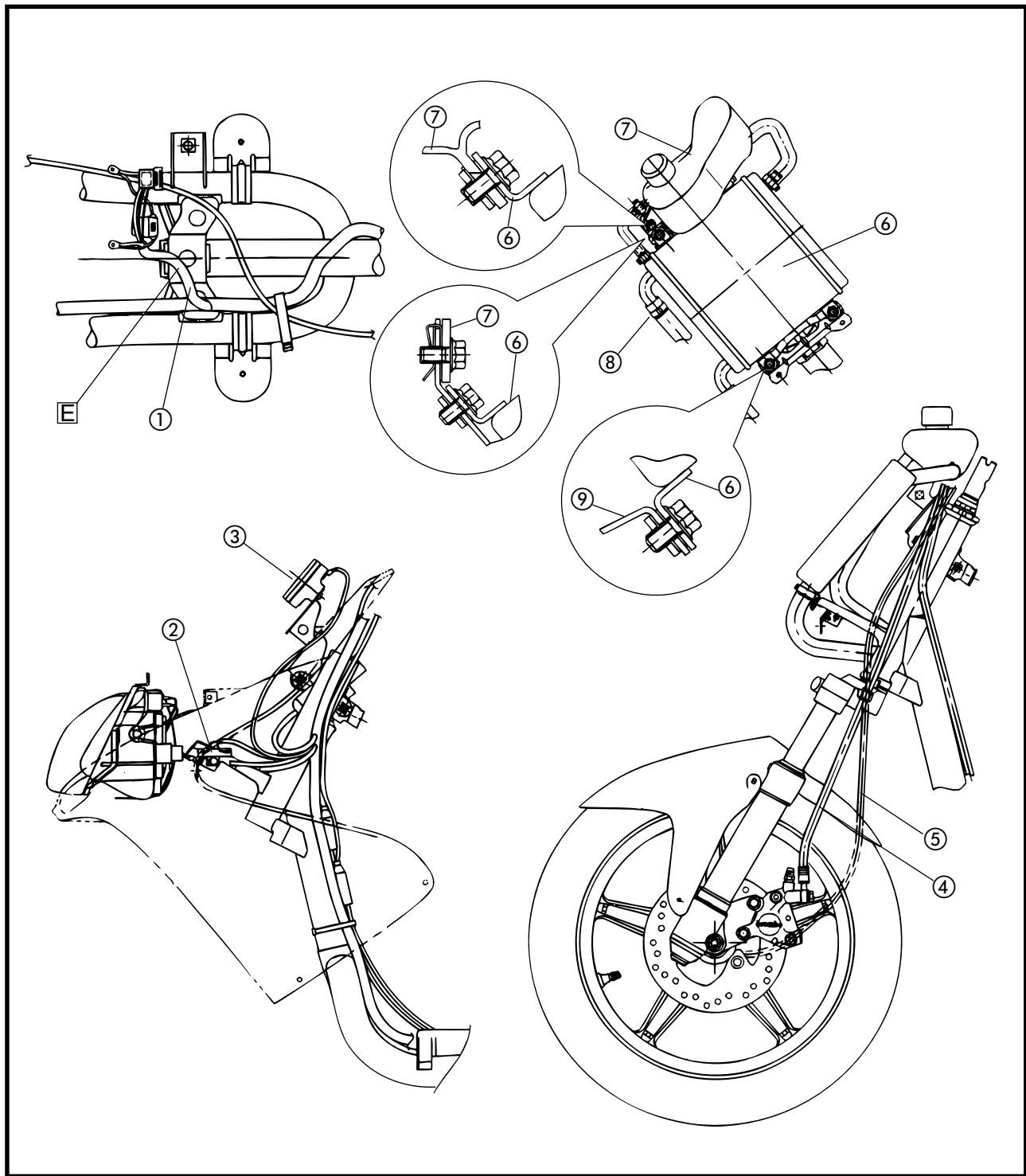

CABLE ROUTING

SPEC	
-------------	---

- ① Rear brake hose
 - ② Seat lock cable
 - ③ Wire harness
 - ④ Throttle cable
 - ⑤ Starter (choke) cable
 - ⑥ Speedometer cable
 - ⑦ Frame
 - ⑧ Oil hose (tank/oil pump)
 - ⑨ Oil hose (oil pump/carburetor)
 - ⑩ Water hoses
- A** Install the rear brake hose in the clip.
 - B** Install the oil delivery hose (from oil pump to carburator) under the water hose.
 - C** Pass the rear brake hose under the frame reinforcement tube.
 - D** Align the mark on the water hose in front of the mark in the water pump housing.
 - E** Pass the speedometer cable through the slot of the front fender.
 - F** Install the 8 clamps just beside the marks at the end side of the hoses.

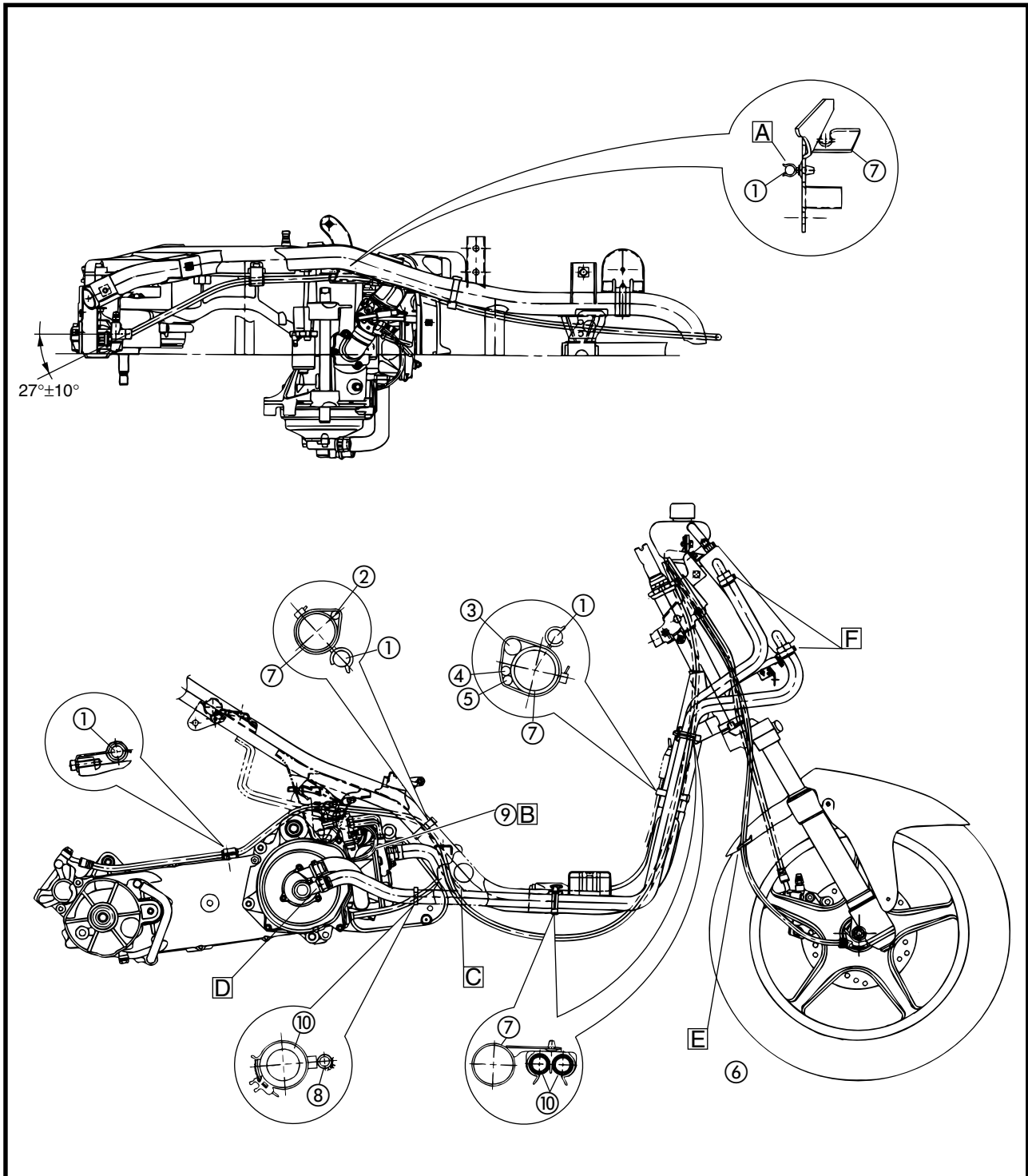



CHK



ADJ



CHAPTER 3. PERIODIC INSPECTION AND ADJUSTMENT

INTRODUCTION	3-1
PERIODIC MAINTENANCE/LUBRICATION INTERVALS	3-1
COVERS	3-3
REMOVAL	3-3
HANDLEBAR COVERS	3-7
REMOVAL	3-7
ENGINE	3-11
ENGINE IDLE SPEED ADJUSTMENT	3-11
THROTTLE CABLE FREE PLAY ADJUSTMENT	3-12
SPARK PLUG INSPECTION	3-13
AUTOLUBE PUMP AIR BLEEDING	3-14
ENGINE OIL LEVEL INSPECTION	3-15
TRANSMISSION OIL REPLACEMENT	3-16
COOLANT LEVEL INSPECTION	3-17
COOLANT REPLACEMENT	3-17
AIR CLEANER ELEMENT CLEANING	3-19
EXHAUST PIPE ASSEMBLY AND ADJUSTMENT	3-20
CHASSIS	3-21
FRONT BRAKE LEVER FREE PLAY ADJUSTMENT	3-21
REAR BRAKE LEVER FREE PLAY ADJUSTMENT	3-21
BRAKE PAD INSPECTION	3-21
BRAKE FLUID LEVEL INSPECTION	3-22
AIR BLEEDING (HYDRAULIC BRAKE SYSTEM)	3-23
STEERING HEAD ADJUSTMENT	3-23
TIRE INSPECTION	3-24
WHEEL INSPECTION	3-25
CABLE INSPECTION AND LUBRICATION	3-25
LEVER LUBRICATION	3-26
CENTERSTAND LUBRICATION	3-26
FRONT FORK INSPECTION	3-26
REAR SHOCK ABSORBER	3-26
ELECTRICAL	3-27
BATTERY INSPECTION	3-27
FUSE INSPECTION	3-28
HEADLIGHT BEAM ADJUSTMENT	3-29
HEADLIGHT LENS REPLACEMENT	3-29
HEADLIGHT BULB REPLACEMENT	3-29

PERIODIC INSPECTION AND ADJUSTMENT

INTRODUCTION

This chapter includes all information necessary to perform recommended inspections and adjustments. These preventive maintenance procedures, if followed, will ensure more reliable vehicle operation and a longer service life. The need for costly overhaul work will be greatly reduced. This information applies to vehicles already in service as well as new vehicles that are being prepared for sale. All service technicians should be familiar with this entire chapter.

PERIODIC MAINTENANCE/LUBRICATION INTERVALS

Unit : Km(miles)

	ITEM	ROUTINE	BREAK-IN 1,000(600)	EVERY	
				3,000 (2,000)or 6 months	6,000 (4,000)or 12 months
1	Spark plug	<ul style="list-style-type: none"> • Check condition. • Clean or replace if necessary. 	○	○	○
2	Air filter	<ul style="list-style-type: none"> • Clean. • Replace if necessary. 		○	○
3	* Carburetor	<ul style="list-style-type: none"> • Check idle speed/choke operation. • Adjust if necessary. 	○		○
4	* Fuel line	<ul style="list-style-type: none"> • Check fuel hose and vacuum pipe for cracks or damage. • Replace if necessary. 		○	○
5	* Transmission oil	<ul style="list-style-type: none"> • Check for oil leakage. • Correct if necessary. • Replace every 12,000 (8,000) or 24 months. (Warm engine before draining.) 	REPLACE	○	○
6	* Autolube pump	<ul style="list-style-type: none"> • Check operation. • Correct if necessary. • Bleed the air. 	○		○
7	* Brakes (front and rear)	<ul style="list-style-type: none"> • Check operation/fluid leakage/See NOTE. • Correct if necessary. 	○	○	○
8	* Cooling system	<ul style="list-style-type: none"> • Check hose condition. • Replace if necessary. • Replace coolant every 12,000 (8,000) or 24 months. 		○	○
9	* Wheels	<ul style="list-style-type: none"> • Check damage/runout/Tightening torque. • Replace/tighten if necessary. 		○	○
10	* Wheel bearings	<ul style="list-style-type: none"> • Check bearing assembly for looseness/damage. • Replace if damaged. 		○	○
11	* Steering bearing	<ul style="list-style-type: none"> • Check bearing assembly for looseness. • Correct if necessary. • Moderately repack every 12,000 (8,000) or 24 months.** 	○	○	○
12	* Rear shock absorber	<ul style="list-style-type: none"> • Check operation/oil leakage. • Replace if necessary. 		○	○
13	* V-belt	<ul style="list-style-type: none"> • Check damage and wear. • Replace if necessary. 			○
14	* Fitting/Fasteners	<ul style="list-style-type: none"> • Check all chassis fittings and fasteners. • Tighten if necessary. 	○	○	○
15	* Centerstand	<ul style="list-style-type: none"> • Check operation. • Repair if necessary. 	○	○	○
16	* Battery	<ul style="list-style-type: none"> • Check specific gravity. • Check breather pipe for proper operation. • Correct if necessary. 		○	○

Items marked with an asterisk (*) require special tools, data and technical skills for servicing. Take the scooter to a Yamaha or MBK Dealer when servicing these items.

** : Medium weight wheel bearing grease.

PERIODIC MAINTENANCE/LUBRICATION INTERVALS

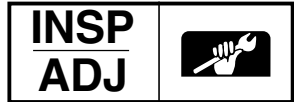

NOTE: _____

Brake fluid replacement:

1. When disassembling the master cylinder or caliper cylinder, replace the brake fluid. Normally check the brake fluid level and add fluid as required.
 2. On the inner parts of the master cylinder and caliper cylinder, replace the oil seals every two years.
 3. Replace the brake hoses every four years, or when cracked or damaged.
-

REMOVAL

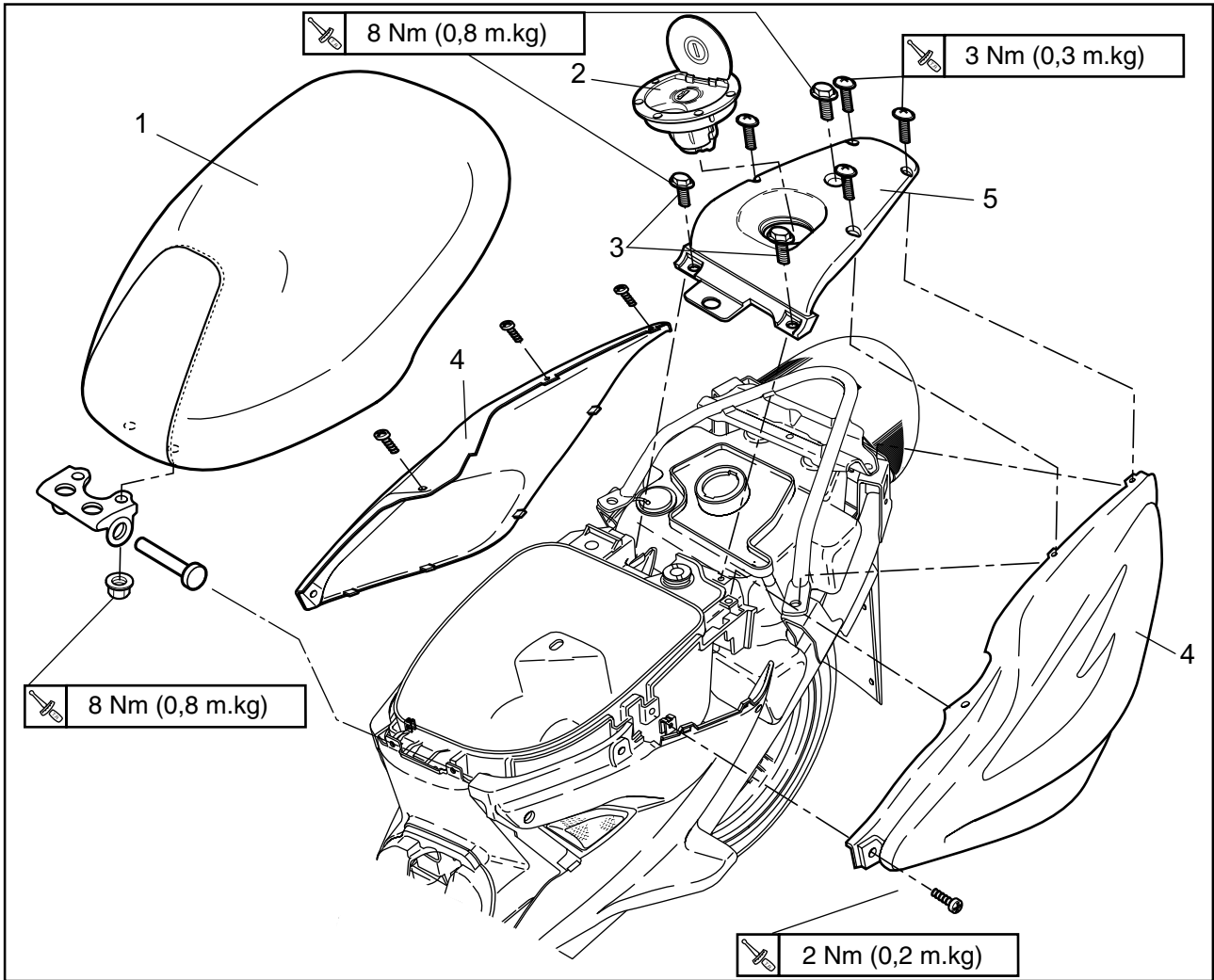

Mark	Name of the intervention/ of the part	Qty	Observation
1	Seat	1	<p>CAUTION: When removing the cover, be careful not to damage the mounting clips.</p> <p>For installation, reverse the "REMOVAL" procedure</p>
2	Fuel tank cap	1	
3	Rear seat screws and strap	2	
4	Side cover (left and right)	2	
5	Rear seat	1	



REMOVAL

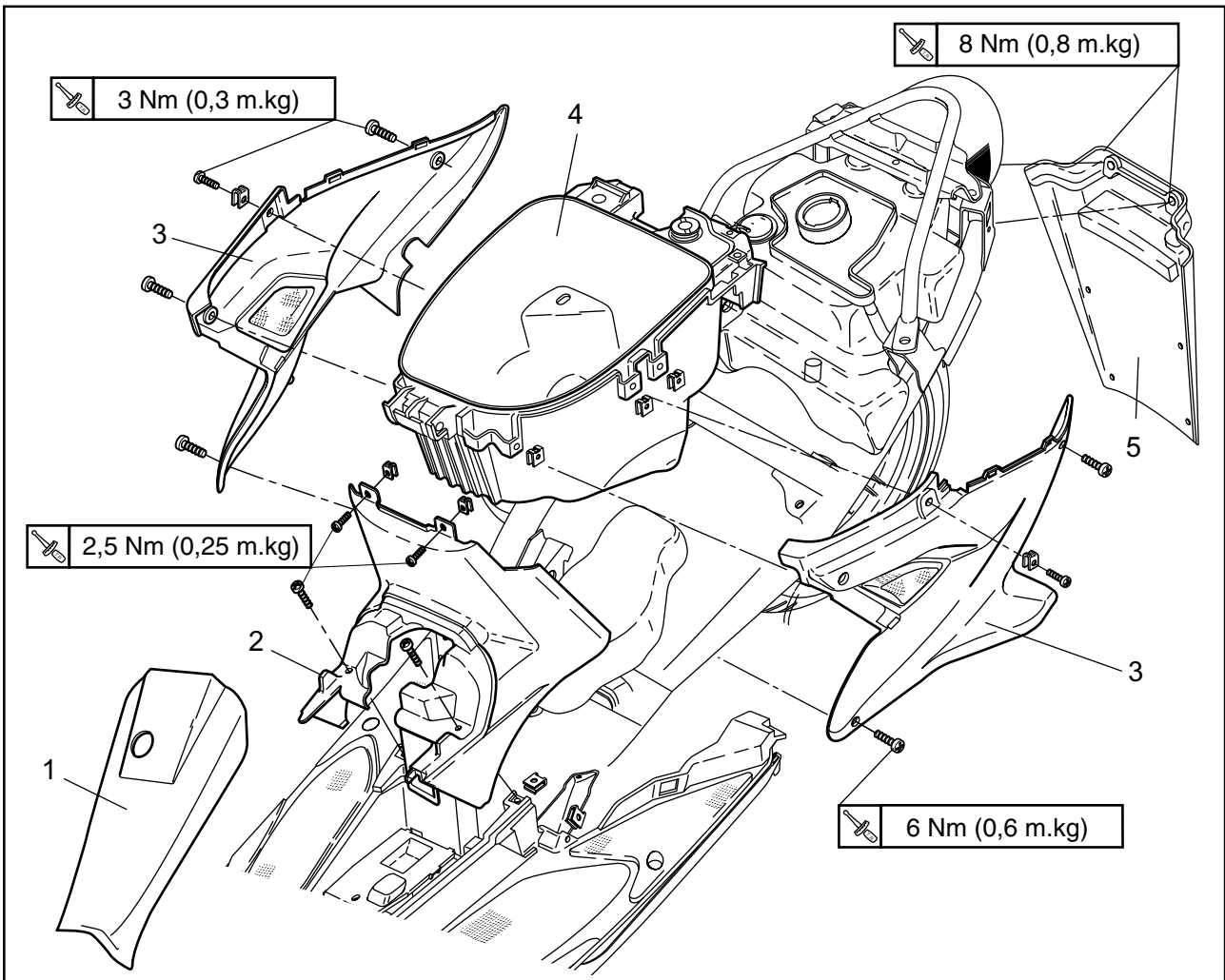

Mark	Name of the intervention/ of the part	Qty	Observation
1	Glove compartment cover	1	<p>CAUTION: When removing the cover, be careful not to damage the mounting clips.</p> <p>For installation, reverse the "REMOVAL" procedure</p>
2	Oil cover	1	
3	Side cover (left and right)	2	
4	Box	1	
5	Rear mudguard	1	



REMOVAL

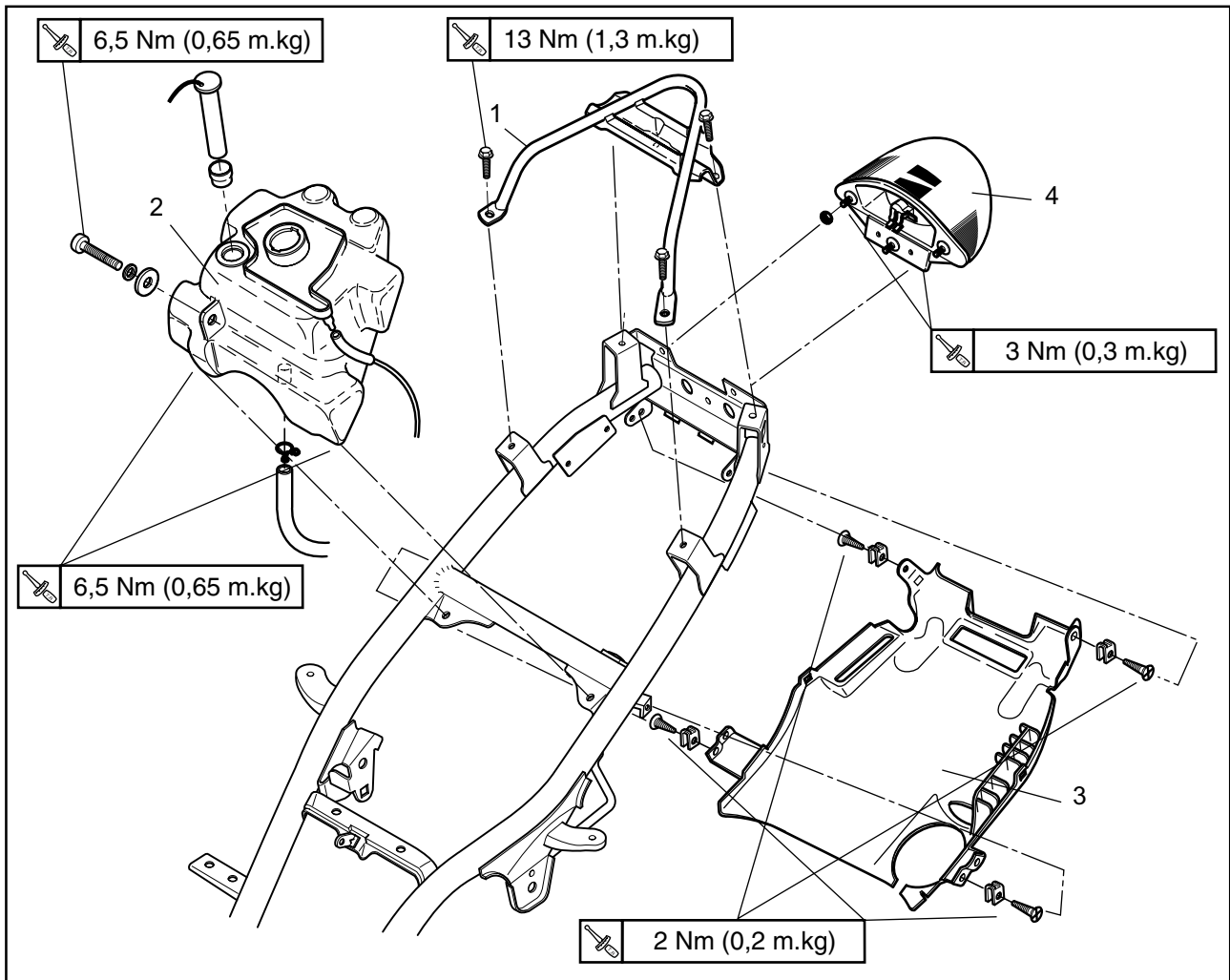

Mark	Name of the intervention/ of the part	Qty	Observation
1	Frame reinforcement	1	<p>CAUTION: When removing the cover, be careful not to damage the mounting clips.</p> <p>For installation, reverse the "REMOVAL" procedure</p>
2	Fuel tank	1	
3	Rear lower cover	1	
4	Rear light	1	

REMOVAL

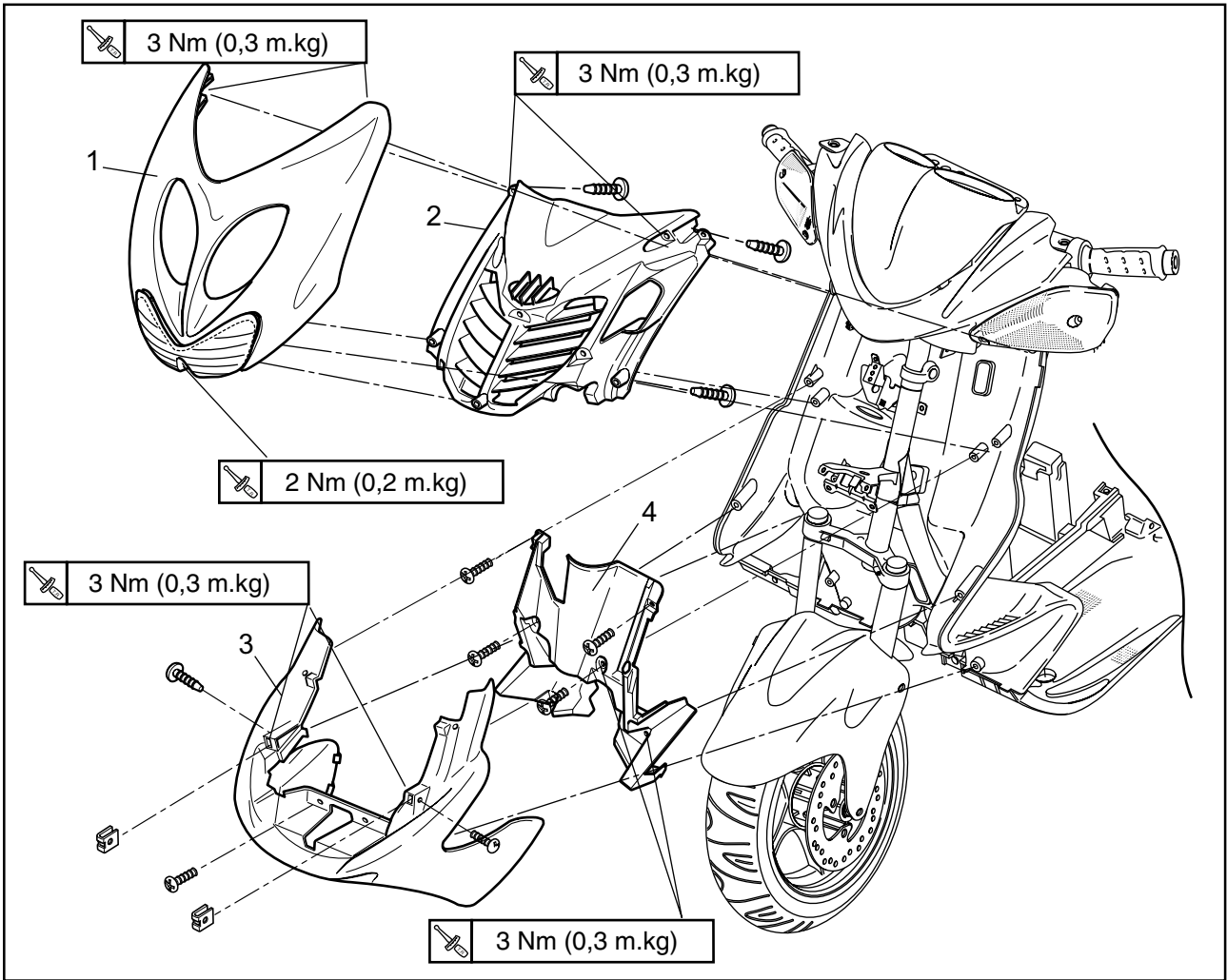

Mark	Name of the intervention/ of the part	Qty	Observation
1	Front cover and headlight	1	<p>CAUTION: When removing the cover, be careful not to damage the mounting clips.</p> <p>For installation, reverse the "REMOVAL" procedure</p>
2	Front inner cover	1	
3	Front fender	1	
4	Front inner panel	1	

HANDLEBAR COVERS

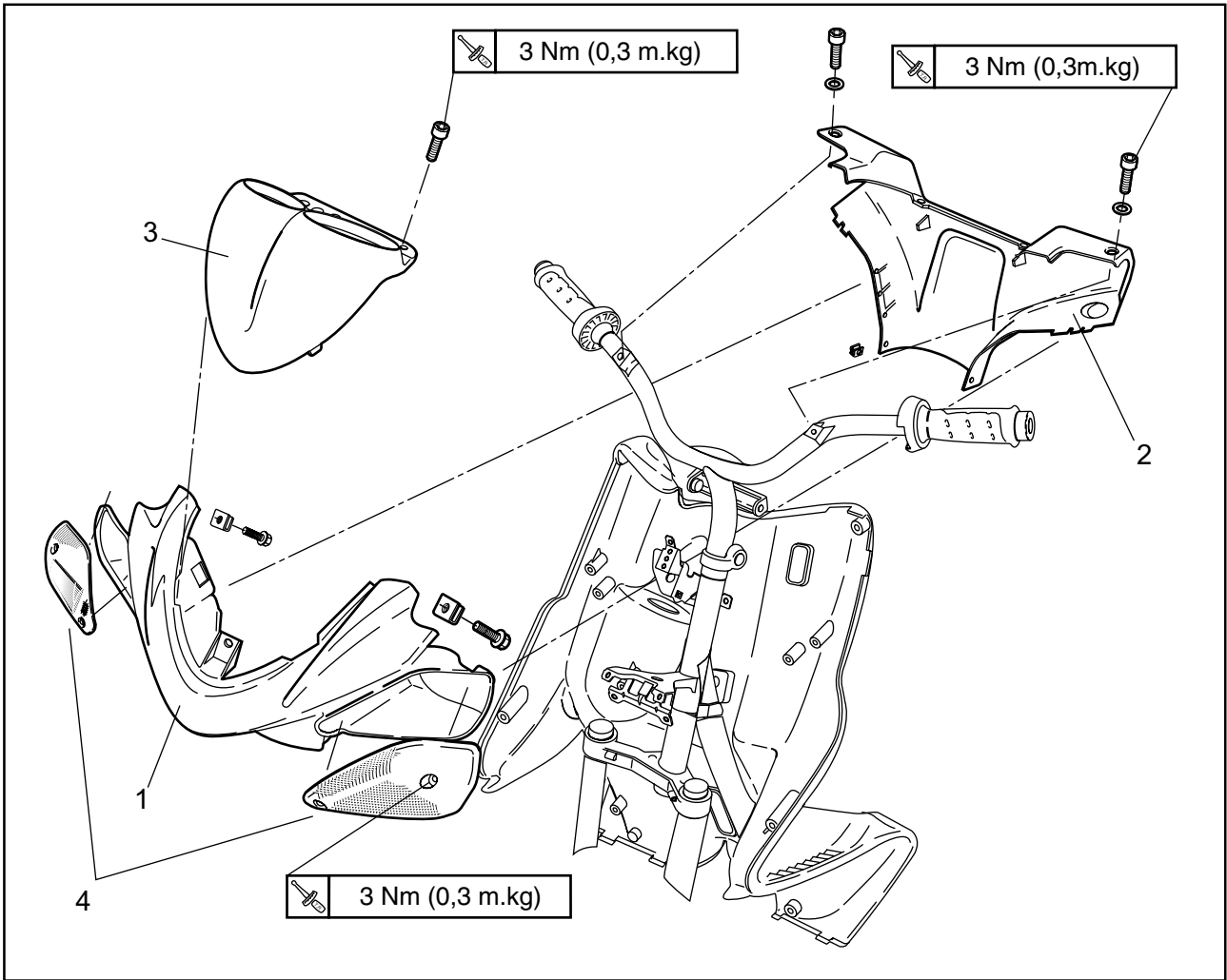

Mark	Name of the intervention/ of the part	Qty	Observation
1	Handlebar cover (front)	1	<p>CAUTION: When removing the cover, be careful not to damage the mounting clips.</p> <p>For installation,reverse the "REMOVAL" procedure</p>
2	Handlebar cover (rear)	1	
3	Meter	1	
4	Flasher light	1	



REMOVAL

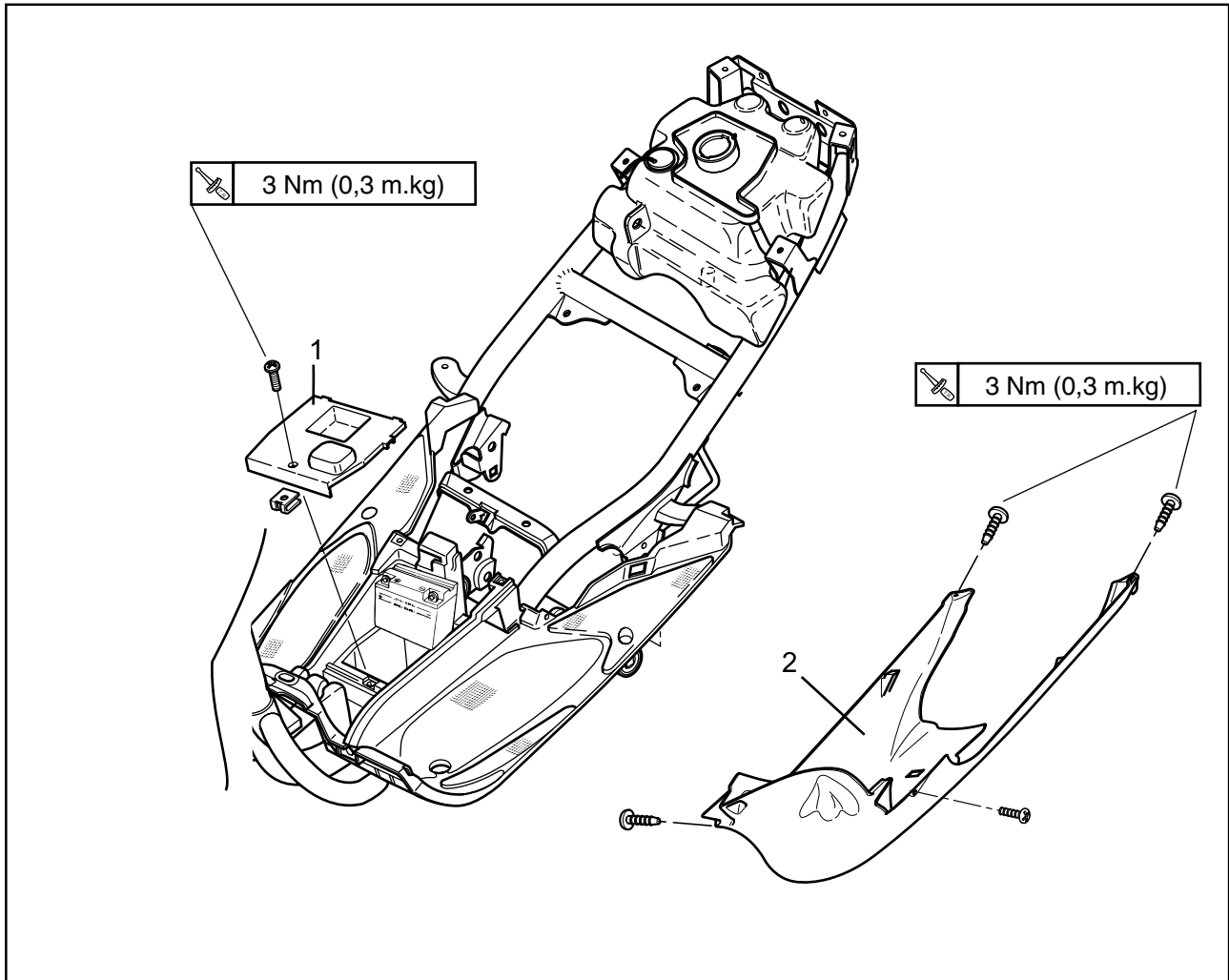

Mark	Name of the intervention/ of the part	Qty	Observation
1	Battery cover	1	
2	Lower cover	1	
			<p>CAUTION: When removing the cover, be careful not to damage the mounting clips.</p>
			<p>For installation, reverse the "REMOVAL" procedure</p>



REMOVAL

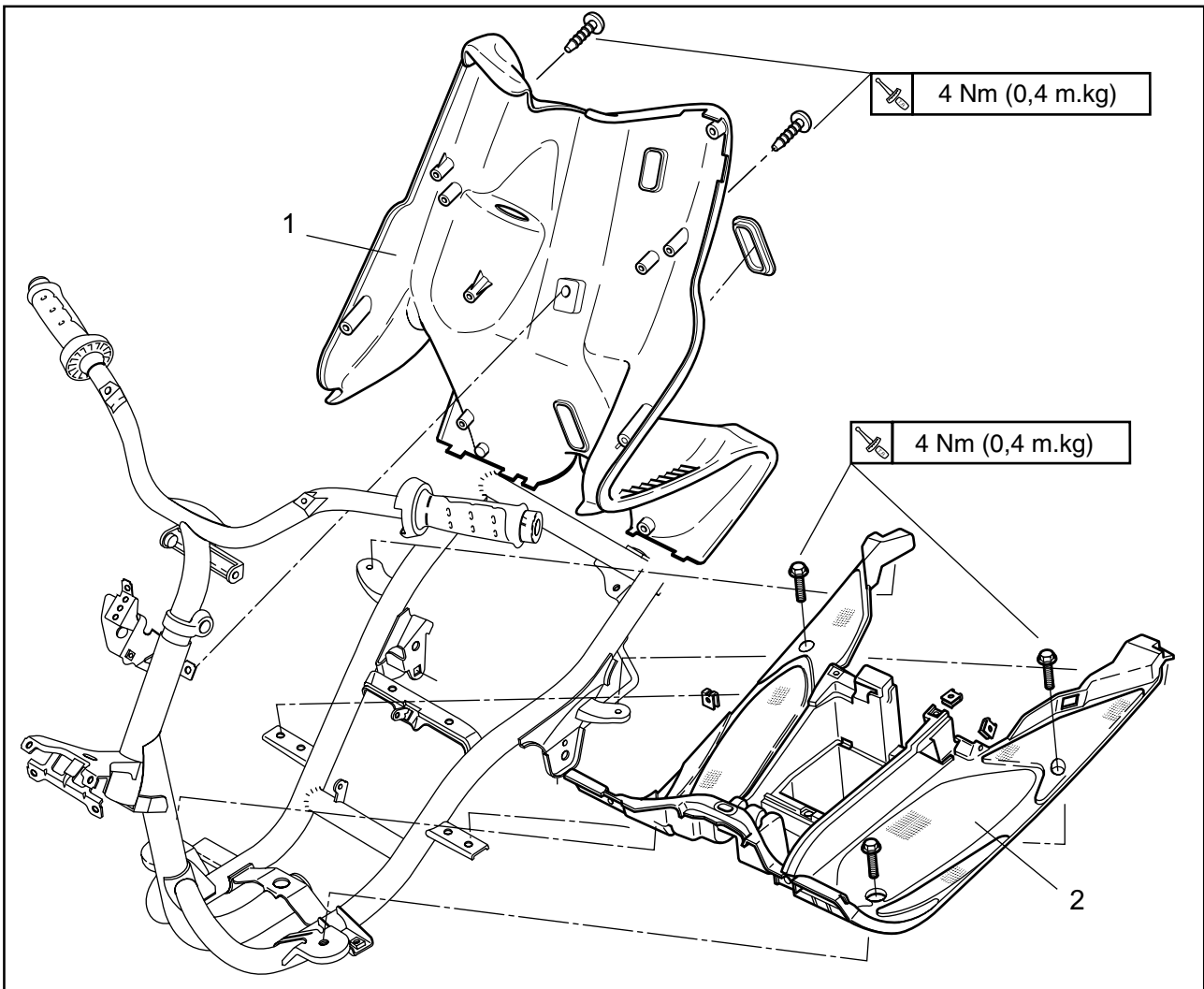

Mark	Name of the intervention/ of the part	Qty	Observation
1	Inner panel	1	Main switch ring. Turn the ring anticlockwise to remove it
2	Footrest board	1	
			<p>CAUTION:</p> <p>When removing the cover, be careful not to damage the mounting clips.</p>
			For installation, reverse the "REMOVAL" procedure

COVERS

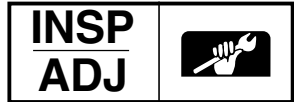

NOTE:

Correct routing of cables and wires is essential for a safe operation of this scooter. Refer to the section "CABLE ROUTING" in Chapter 2.

NOTE:

Be careful not to pinch any wires with the covers.

NOTE:

When installing the covers, be careful not to damage the mounting clips.



ENGINE

ENGINE IDLE SPEED ADJUSTMENT

1. Tighten :

- Pilot air screw

Turn the pilot air screw in until lightly seated.

2. Loosen :

- Pilot air screw

Back out from the lightly seated position.



Pilot air screw position :
DELL'ORTO

1-3/8 turns out \pm 1/8 (F)(B)(P)(I)(E)

1-3/4 turns out \pm 1/8 (D)

1-5/8 turns out \pm 1/8 (NL)

2 \pm 1/8 turns out (CHE)

3. Start the engine and let it warm up for several minutes.

WARNING

For safety reasons, place the scooter on the center stand before starting the engine.

4. Attach :

- Inductive tachometer
(to the spark plug lead)



Inductive tachometer:
Ref: 90890-03113

5. Check :

- Engine idle speed
Out of specification → Adjust.



Engine idle speed :
1800 \pm 200 r/min

ENGINE IDLE SPEED ADJUSTMENT/ THROTTLE CABLE FREE PLAY ADJUSTEMENT

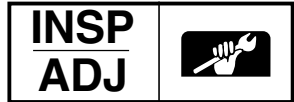

6. Adjust :

- Engine idle speed

Adjustment steps :

- Turn the throttle stop screw in or out until specified idling speed is obtained.

Turning left	Idling speed increased.
Turning right	Idling speed decreased.

THROTTLE CABLE FREE PLAY ADJUSTMENT

1 Check :

- Throttle cable free play

Out of specification → Adjust.

	Free play : 1,0 ~ 3,0 mm (0.04 ~ 0.19 in)
--	---

Throttle cable free play adjustment steps :

NOTE: _____

Before adjusting the throttle cable free play, the engine idle speed should be adjusted.

First step :

- Loosen the locknut on the throttle cable.
- Turn the adjuster in or out until the specified free play is obtained.

Turning left	Free play increased.
Turning right	Free play decreased.

- Tighten the locknuts.

⚠ WARNING _____

After adjusting, turn the handlebar to the right and left, making sure that the engine idling speed does not change.

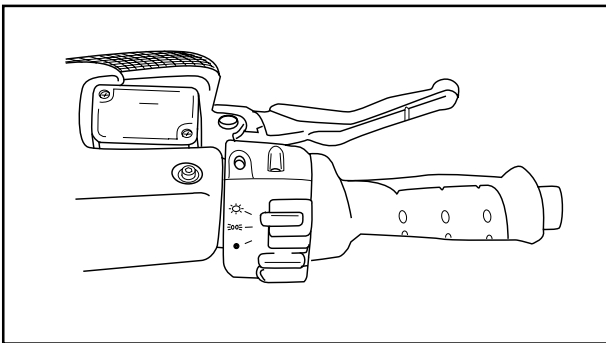

SPARK PLUG INSPECTION

INSP
ADJ



SPARK PLUG INSPECTION

1. Remove :
 - Spark plug
2. Inspect :
 - Electrode ①
Wear/Damage → Replace.
 - Insulator ②
Abnormal color → Replace.

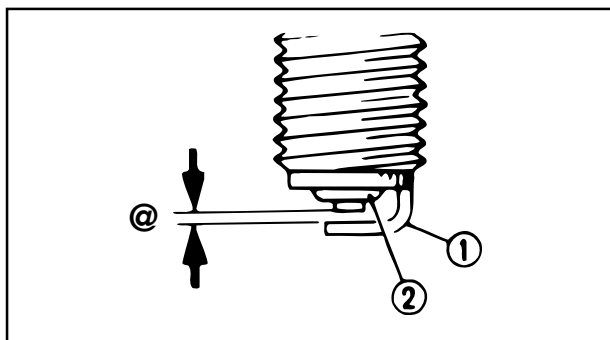

**Standard spark plug :
BR8HS (NGK)**

3. Measure :
 - Plug gap @
Out of specification → Adjust.
Use a wire gauge or feeler gauge.



**Spark plug gap @ :
0,5 ~ 0,7 mm (0.019 ~ 0.027 in)**

4. Tighten :
 - Spark plug
Before installing the spark plug, clean the gasket surface and plug surface.

NOTE: _____
First tighten by hand, then torque to specification.



**Spark plug :
20 Nm (2.0 m.kg)**



AUTOLUBE PUMP AIR BLEEDING

1. Bleed :

- Pump housing and oil hose

Pump bleeding steps :

- Place a rag under the pump.
- Remove the bleed screw .
- Let oil run until there are no more air bubbles in it.
- When there are no more bubbles, tighten the bleed screw.

NOTE: _____

Check the condition of the bleed screw gasket. If it is damaged, replace it with a new one.

- Start the engine.
- Let the engine run two or three minutes at 2000 rpm. This will force out any air in the hose.

ENGINE OIL LEVEL INSPECTION

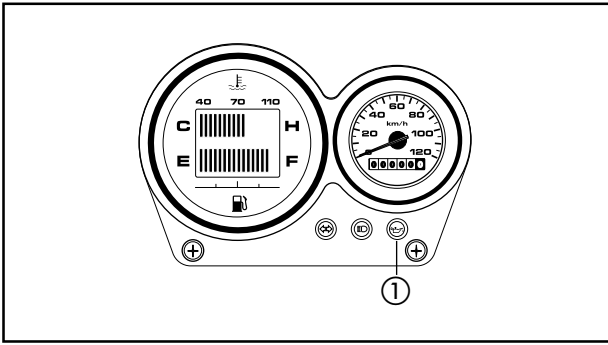
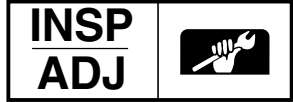

ENGINE OIL LEVEL INSPECTION

1. Inspect :

- Oil level
Oil level low → Add oil to proper level as follows.

① "OIL" indicator light

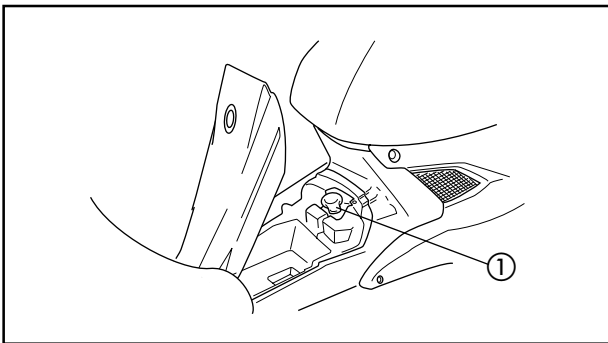
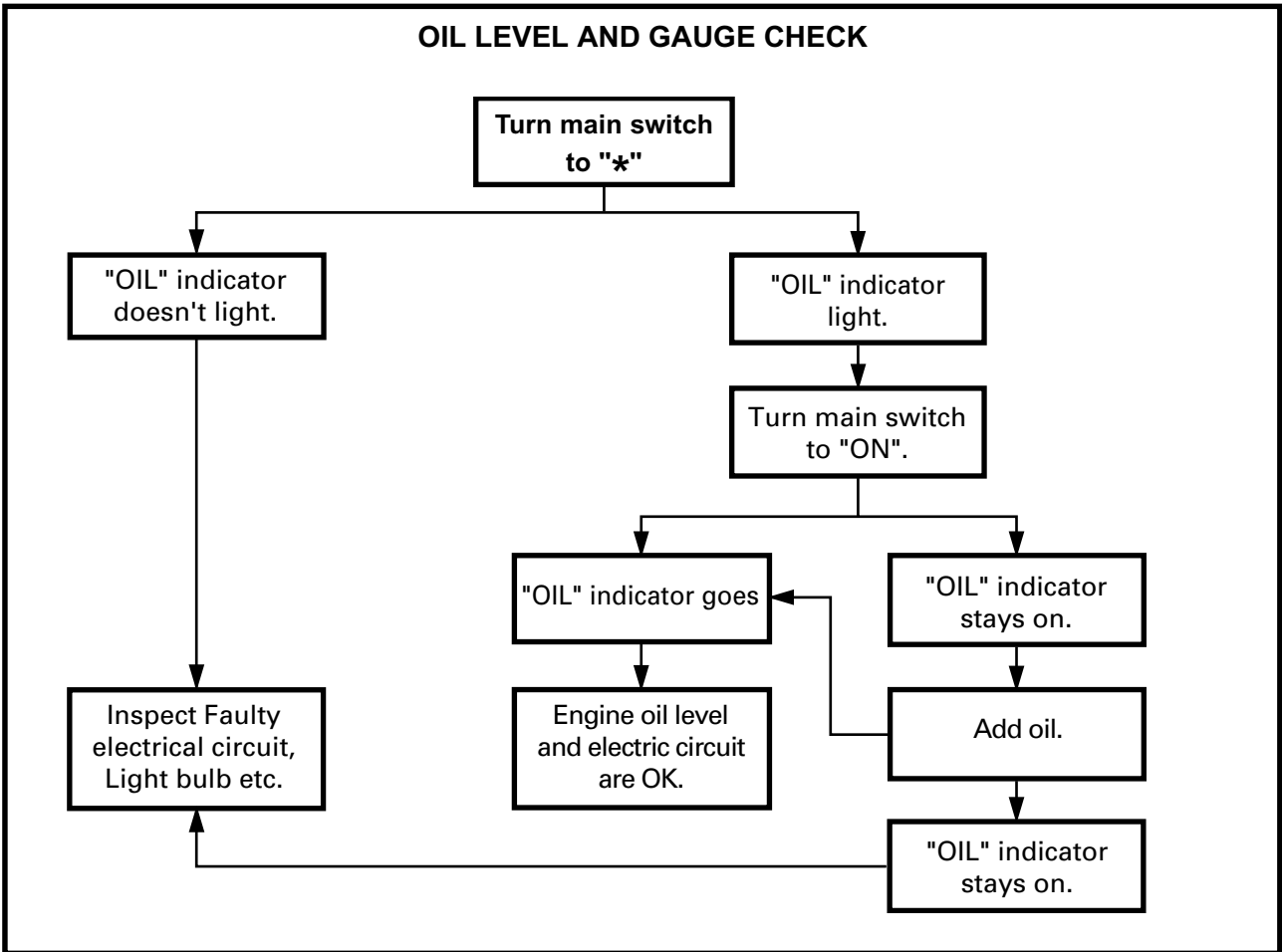

Recommended oil :
Semi-synthetic oil in accordance with APITC TSC3 STANDARD.
Capacity :
Total:
1.3 L (1.14 Imp qt, 1.37 US qt)

NOTE: _____
 Install the oil tank filler cap ① and push it fully into the filler.

CAUTION: _____
 Always use the same type of engine oil; mixing oils may result in a harmful chemical reaction and lead to poor performance.

TRANSMISSION OIL REPLACEMENT

INSP
ADJ

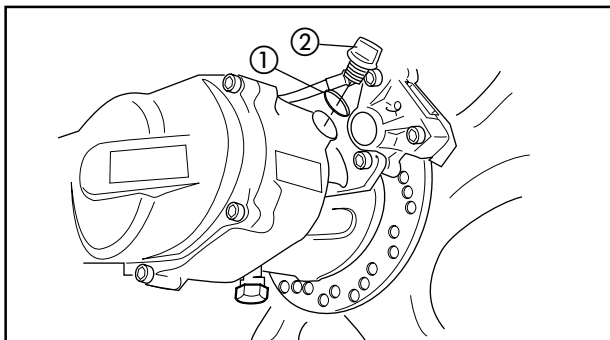
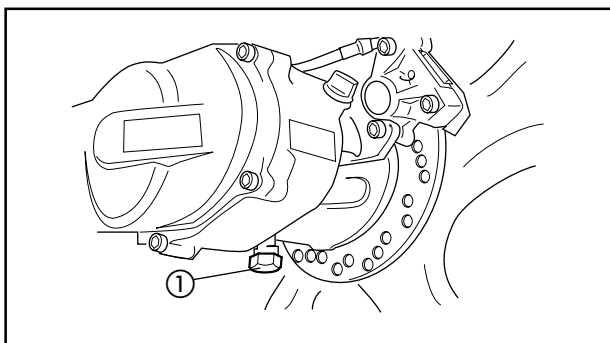

TRANSMISSION OIL REPLACEMENT

1. Remove :

- Drain plug ①
- Oil filler plug ②

Drain the transmission oil.

2. Check :

- Gasket (drain plug)
 - O-ring (oil filler plug)
- Damaged → Replace.

3. Install :

- Gasket ①
- Drain plug



Drain plug :
18 Nm (1.8 m.kg)

4. Fill :

- Transmission case



Transmission oil :
SAE 10W30 type SE motor oil.
Capacity :
Periodic replacement
0.11 L (0.10 Imp qt ; 0.12 US qt)
Total amount
0.13 L (0.11 Imp qt ; 0.13 US qt)

NOTE: _____

Wipe off any oil spilt on the crankcase, tire or wheel.

5 Install :

- Oil filler plug

COOLANT LEVEL INSPECTION/ COOLANT REPLACEMENT

INSP
ADJ



COOLANT LEVEL INSPECTION

NOTE: _____

Install the scooter straight up when inspecting the coolant level.

1. Place the scooter on a level surface.

NOTE: _____

Place the scooter on its centerstand.

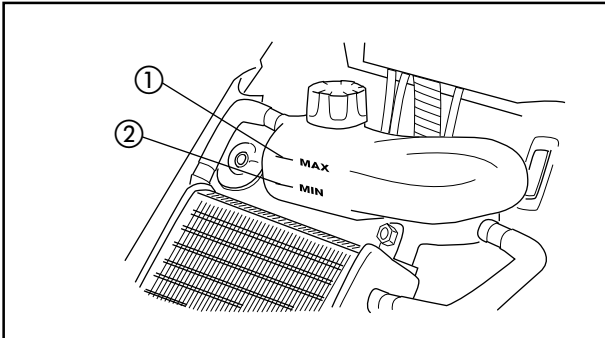

2. Remove:

- Front cover

Refer to the section "COVER"

3. Inspect:

- Coolant level

Coolant level should be between maximum ① and minimum ② marks.

Coolant level low → Add recommended coolant to proper level.

CAUTION: _____

Hard water or salt water is harmful to the engine parts; use boiled or distilled water if you can't get soft water.

4. Install:

- Front cover

Refer to the section "COVER"

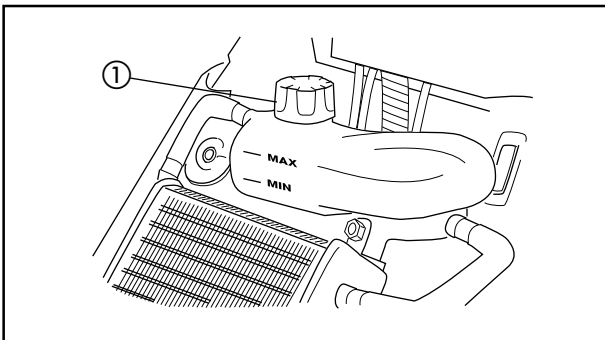

COOLANT REPLACEMENT

1. Remove:

- Front cover

Refer to the section "COVER"

- Radiator cap ①

⚠ WARNING _____

Do not remove the radiator cap when the engine and radiator are hot. Scalping hot fluid and steam may be blown out under pressure, which could cause serious injury. When the engine has cooled, open the radiator cap by following this procedure:

Place a thick rag or a towel over the radiator cap. Slowly rotate the cap counterclockwise

COOLANT REPLACEMENT

INSP
ADJ



toward the detent. This allows any residual pressure to escape. When the hissing sound has stopped, press down on the cap while turning counterclockwise and remove it.

NOTE: _____

Position the scooter straight up when replacing the coolant.

2. Place the scooter on a level surface.

NOTE: _____

Place the scooter on its centerstand if.

3. Remove:

- Water pump fixing bold
- Drain the radiator and engine of its coolant.

4. Install:

- Gasket
- Water pump fixing bold.

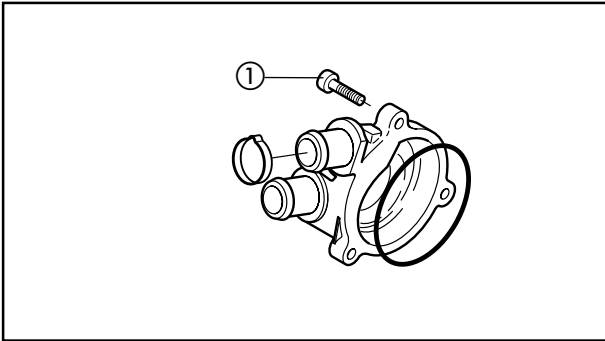

Water pump fixing bold:
7 Nm (0.7 m.kg)

5. Fill:

- Cooling system (radiator, engine and hoses) (to specified level)



Recommended coolant:
High quality ethylene glycol antifreeze containing corrosion inhibitors for aluminum engines.
Radiator capacity (including all routes):
1.2 L (1.05 Imp qt, 1.27 US qt)
From lower to upper level:
0.15 L (0.13 Imp qt, 0.16 US qt)

AIR CLEANER ELEMENT CLEANING

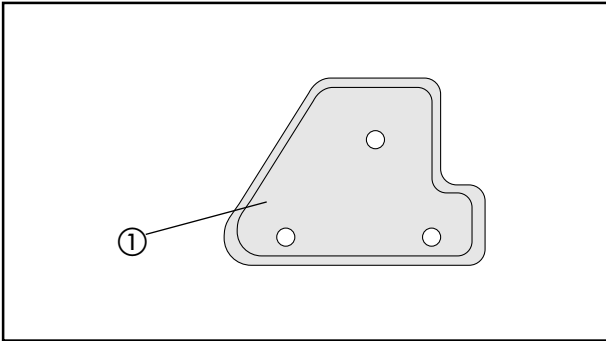
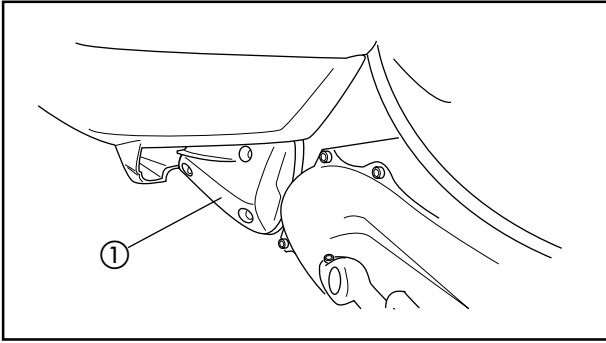
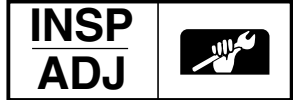

AIR CLEANER ELEMENT CLEANING

- 1. Remove :
 - Air cleaner case cover ①
- 2. Remove :
 - Air filter element

CAUTION: _____

Never operate the engine with the air cleaner element removed. Unfiltered air will cause rapid wear of engine parts and possible engine damage.

- 3. Inspect :
 - Element ①
Damage → replace.
- 4. Clean :
 - Air filter element

Cleaning steps :

- Wash the element gently but thoroughly in solvent.

⚠ WARNING _____

Never use low flashpoint solvents such as gasoline to clean the element. Such solvents may lead to fire or explosion.

- Squeeze excess solvent out of the element and let dry.

CAUTION: _____

Do not twist the element.

- Apply foam air filter oil or SAE 10W30 typ SE oil on the element.
- Squeeze out the excess oil.

NOTE: _____

The element should be wet but not dripping.

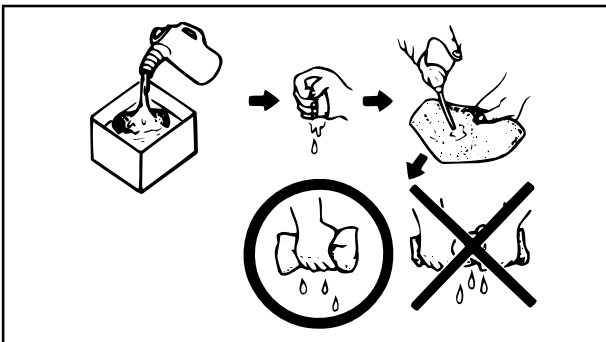

EXHAUST PIPE ASSEMBLY AND ADJUSTMENT

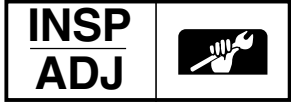

MUFFLER

- ① Exhaust pipe
- ② Cylinder
- ③ Crankcase
- ④ Bolt
- ⑤ Bolt
- ⑥ Gasket

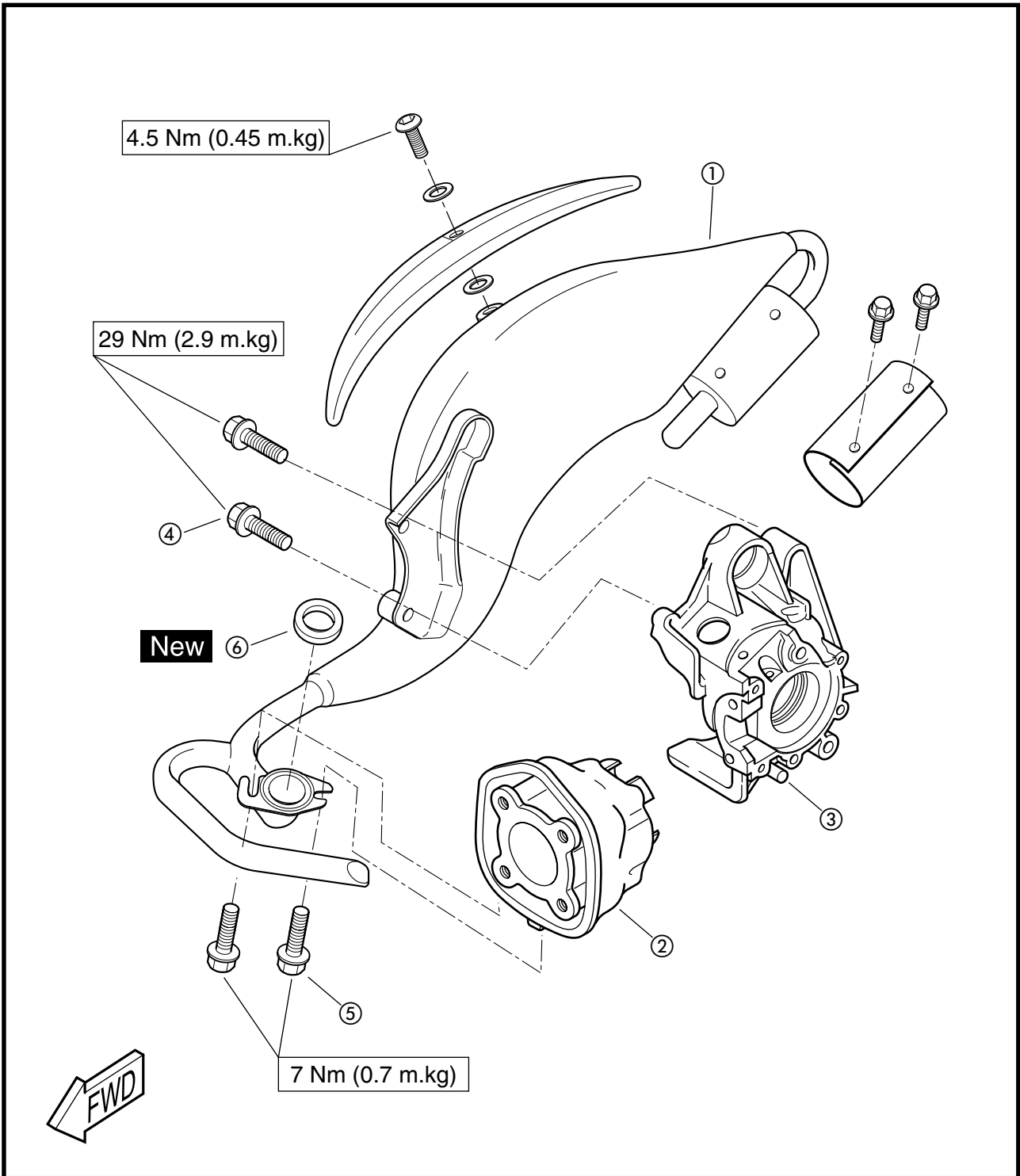

FRONT BRAKE LEVER FREE PLAY ADJUSTEMENT/ REAR BRAKE LEVER FREE PLAY ADJUSTEMENT/ BRAKE PAD INSPECTION

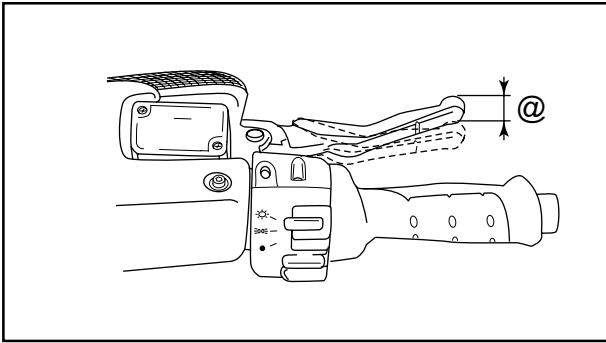
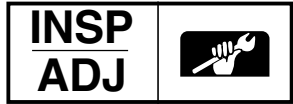

CHASSIS

FRONT BRAKE LEVER FREE PLAY ADJUSTMENT

1. Check :
 - Front brake lever free play @
Out of specification → Adjust.

	Free play : 10 ~ 20 mm (0.40 ~ 0.80 in)
--	--

⚠ WARNING

A soft or spongy feeling in the brake lever can indicate the presence of air in the brake system. This air must be removed by bleeding the brake system before the scooter is operated. Air in the system will reduce brake performance and can result in loss of control and an accident. Inspect and bleed the system if necessary.

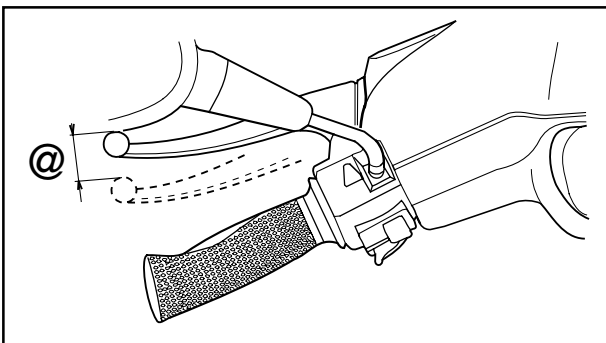

REAR BRAKE LEVER FREE PLAY ADJUSTMENT

1. Check :
 - Rear brake lever free play @
Out of specification → Adjust.

	Free play : 10 ~ 20 mm (0.40 ~ 0.80 in)
--	--

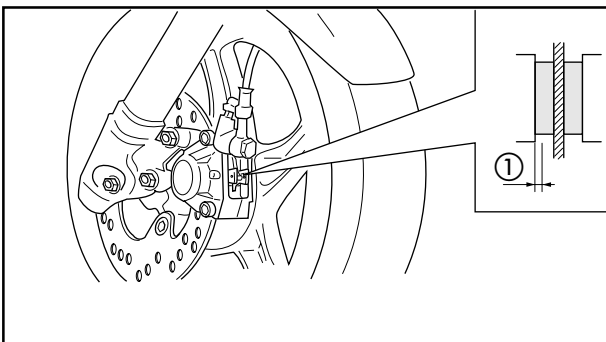

BRAKE PADS INSPECTION

1. Measure :
 - Brake pads
Out of specification → Replace.

NOTE: _____
Replace the brake pad and spring as a set when replacing the brake pads.

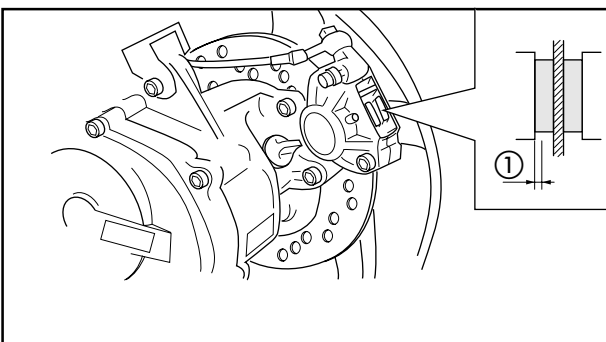

	Wear limit ① : 2,0 mm (0.08 in)
--	------------------------------------

BRAKE FLUID LEVEL INSPECTION

NOTE:

Position the scooter straight up when inspecting the fluid level, and make sure by turning the handlebar that the top of the master cylinder is horizontal.

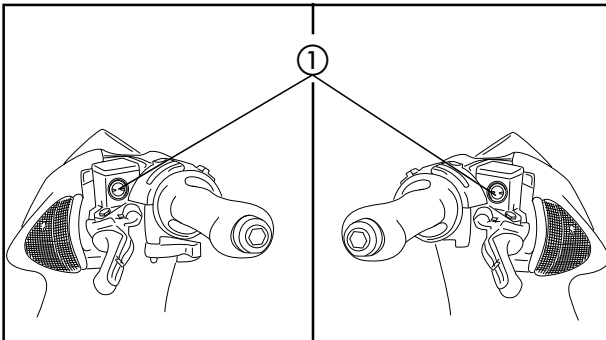

1. Inspect :

- Brake fluid level

Brake fluid level is under "LOWER" level line

① → Fill to proper level.



Recommended brake fluid :
DOT # 3 or DOT # 4

CAUTION:

The brake fluid may corrode painted surfaces or plastic parts. Always clean up spilled fluid immediately.

⚠ WARNING

- Use only the designated quality fluid. Otherwise, the rubber seals may deteriorate causing leakage and poor brake performance.
- Refill with the same type of fluid. Mixing fluids may result in a harmful chemical reaction leading to poor brake performance.
- Be careful that water does not enter the master cylinder when refilling. Water will significantly lower the boiling point of the fluid and may result in vapor lock.

AIR BLEEDING (HYDRAULIC BRAKE SYSTEM)/ STEERING HEAD ADJUSTEMENT

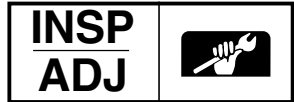

AIR BLEEDING (HYDRAULIC BRAKE SYSTEM)

1. Bleed :
- Brake fluid.

Air bleeding steps :

- Add proper brake fluid into the reservoir.
- Install the diaphragm. Be careful not to spill any fluid or allow the reservoir to overflow.
- Connect a clear plastic tube ① tightly to the caliper bleed screw.
- Place the other end of the tube into a container.
- Slowly apply the brake lever several times.
- Pull the lever as far as possible and hold it there.
- Loosen the bleed screw and pull the lever all the way.
- When the lever is completely pulled, tighten the bleed screw, then release the lever.
- Repeat steps (e) to (h) until all air bubbles have been removed from the system.
- Add brake fluid to proper level.

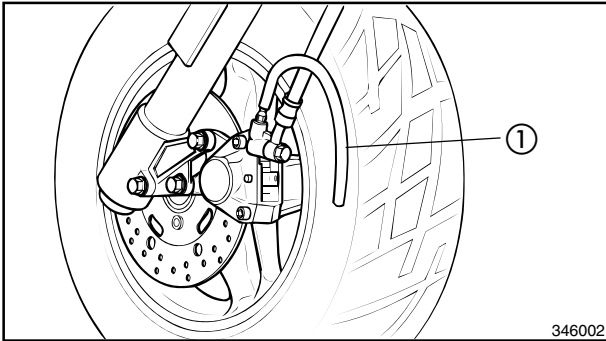

⚠ WARNING

Check the operation of the brake after bleeding the brake system.

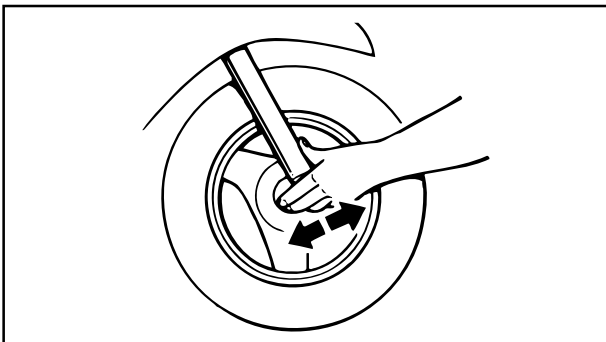

STEERING HEAD ADJUSTMENT

- 1 Check :

- Steering assembly bearings
- Grasp the bottom of the forks and gently rock the fork assembly back and forth.

Looseness → Adjust steering head.

Steering head adjustment steps :

- Remove the front fender and the front panels. Refer to "COVERS REMOVAL" .
- Unscrew the securing nut ①
- Tighten the nut ②

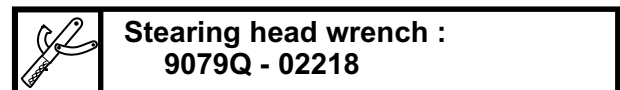
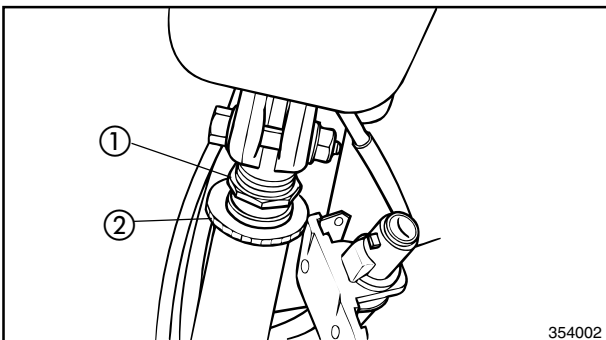

AIR BLEEDING (HYDRAULIC BRAKE SYSTEM/ STEERING HEAD ADJUSTEMENT

INSP
ADJ

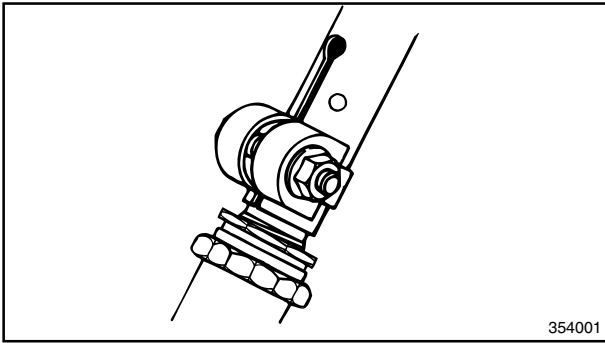

354001



Securing nut :
23 Nm (2.3 m.kg)

NOTE :

Install the torque wrench on the ring nut wrench so that it makes a 90° angle with it.

- Move the handlebar up and down and from front to rear. If steering play is too important, tighten the nut to the specified torque.



Steering head nut :
60 Nm (6.0 m.kg)

TIRE INSPECTION

1. Measure :

- Air pressure
Out of specification → Adjust.

Tire pressure (cold)	Front	Rear
Up to 90 kg	150 kPa (1.50 kgf/cm ²)	150 kPa (1.50 kgf/cm ²)
90 kg ~ maximum load *	150 kPa (1.50 kgf/cm ²)	150 kPa (1.50 kgf/cm ²)
Maximum load :	180 kg (396.9 lb)	

* Maximum load is the total weight of rider, passenger, accessories and luggage.

▲ WARNING

Proper loading of your scooter is important for the handling, braking, and other performance and safety characteristics of your scooter. Do not carry loosely packed items that can shift.

Securely pack your heaviest items close to the center of the scooter, and distribute the weight evenly from side to side. And check the condition and pressure of your tires. **NEVER OVERLOAD YOUR SCOOTER.**

Make sure the total weight of the cargo, rider, passenger, and accessories (fairing, saddlebags, etc. if approved for this model) does not exceed the maximum load of the scooter. Operation of an overloaded scooter could cause tire damage, an accident, or even injury.

TIRE INSPECTION/WHEEL INSPECTION/ CABLE INSPECTION AND LUBRICATION

INSP
ADJ

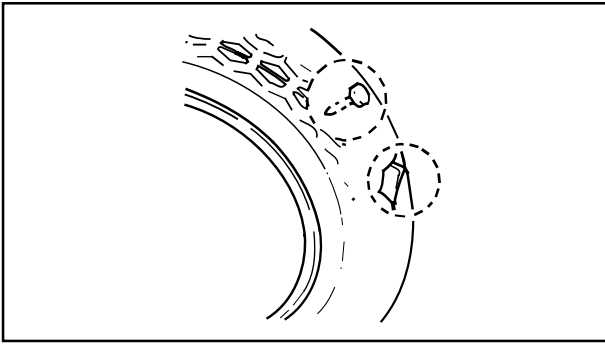

2 Inspect :

- Tire surface
Wear/Damage/Cracks/Road hazards → Replace.
 - Aluminum wheels
Damage/Bends → Replace.
- Never attempt even small repairs to the wheel.

⚠ WARNING

Ride conservatively after installing a tire to allow it to seat itself properly on the rim.

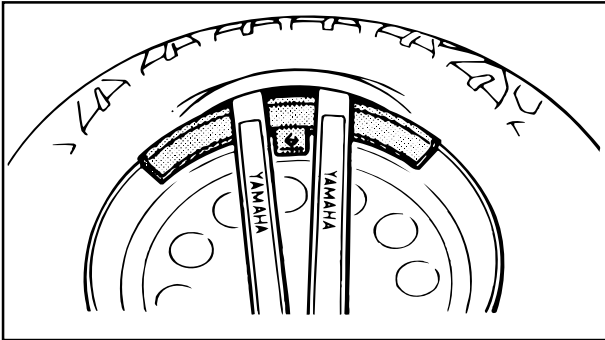

- If the tire is removed with a tire lever, use a suitable protection to prevent damaging the rim.
- When installing the tire, make sure the arrow points to the front.

3. Measure :

- Tire tread depth
Out of specification → Replace.

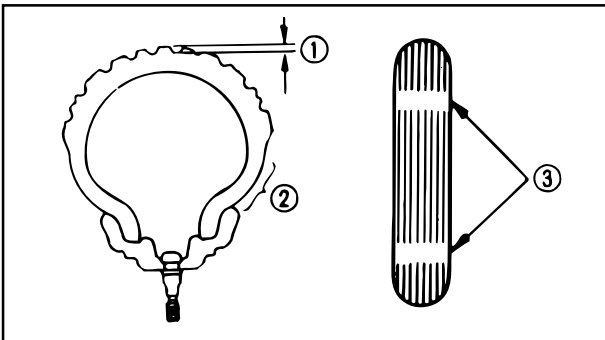

**Minimum tire tread depth
(front and rear) :
0,8 mm (0.03 in)**

- ① Tread depth
- ② Side wall
- ③ Wear indicator

WHEEL INSPECTION

1. Inspect :

- Wheels
Damage/Bends → Replace.

⚠ WARNING

Never attempt even small repairs to the wheel.

CABLE INSPECTION AND LUBRICATION

⚠ WARNING

A damaged cable sheath will rapidly corrode. As a result, the cable cannot move smoothly inside the sheath. Since this situation is dangerous, replace a damaged cable immediately.

1. Check :

- Cable sheath
- Cable end
Damage → Replace.

CABLE INSPECTION AND LUBRICATION/ FRONT FORK INSPECTION/ REAR SHOCK ABSORBER

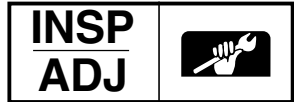

2. Check :
- Cable movement
Stickiness → Lubricate.

 **Recommended lubricant :**
Engine oil SAE 10W30

NOTE: _____
Hold the cable end up and pour a few drops of oil into the sheath.

3. Lubricate the throttle cable end and the cable guide notch on the throttle grip with grease ①.

 **Recommended lubricant :**
Lithium soap based grease

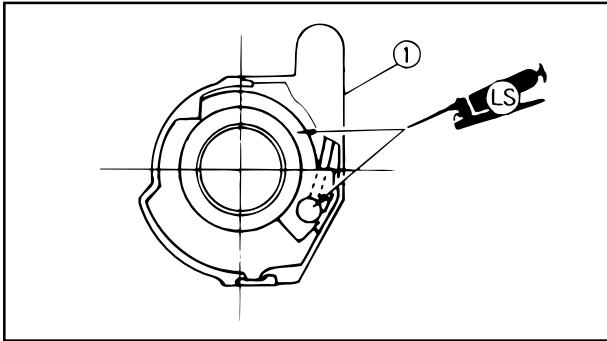

LEVER LUBRICATION

1. Lubricate rotating parts of the levers

 **Recommended lubricant :**
Engine oil SAE 10W30

CENTERSTAND LUBRICATION

1. Lubricate rotating parts

 **Recommended lubricant :**
Engine oil SAE 10W30

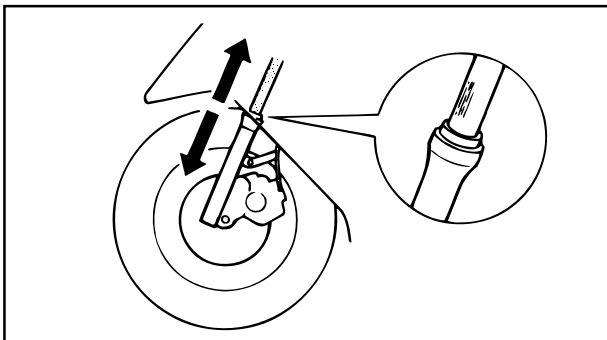

FRONT FORK INSPECTION

1. Check :
- Front fork
Bend/Damage → Replace fork assembly as a set.
Excessive oil leakage → Replace fork assembly as a set.
Unsmooth operation → Replace fork assembly.

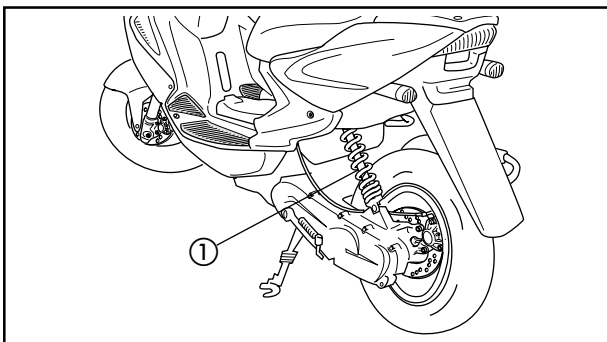

REAR SHOCK ABSORBER

1. Check :
- Rear shock absorber ①
Oil leaks/Damage → Replace.
2. Check :
- Tightening torque

 **Upper bolt :**
31 Nm (3.1 m.kg)
Lower bolt :
18 Nm (1.8 m.kg)

BATTERY INSPECTION

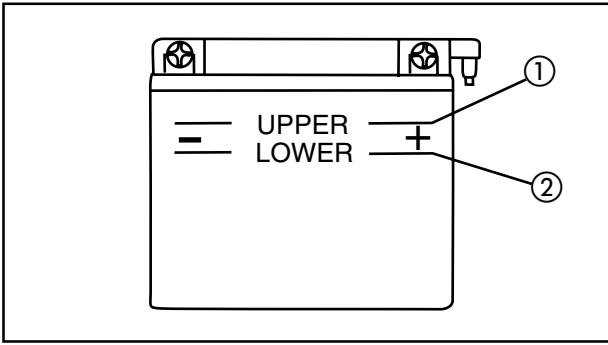
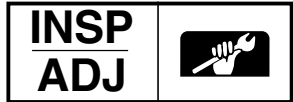

ELECTRICAL BATTERY INSPECTION

1. Inspect :
 - Battery fluid level
Fluid level low → Add to proper level.
Fluid level should be between upper and lower level marks.
- ① Upper level
② Lower level

CAUTION: Refill with distilled water only. Tap water contains minerals which are harmful to a battery.

2. Inspect :
 - Breather hose
Obstruction → Remove.
3. Inspect :
 - Battery

Replace the battery if :

- Battery voltage will not rise to a specific value or bubbles fail to rise during charging.
- Sulfation of one or more cells occurs. (As indicated by the plates turning white, or an accumulation of material in the bottom of the cell.)
- Specific gravity readings after a long, slow charge indicate that one cell is lower than the rest.
- Warpage or buckling of plates or insulators is evident.

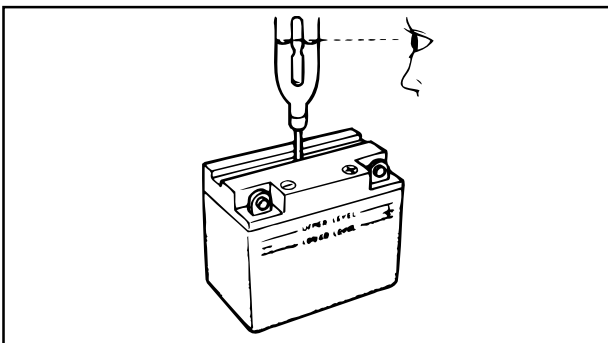

4. Measure :
 - Specific gravity
Less than 1.280 → Recharge battery.

	Charging Current : 0.4 amps/10 hrs
	Specific Gravity : 1.280 at 20°C (68° F)

CAUTION:

Always charge a new battery before using it to ensure maximum performance.

⚠ WARNING

Battery electrolyte is dangerous. It contains sulfuric acid which is poisonous and highly caustic.

Always follow these preventive measures :

- Avoid bodily contact with electrolyte as it can cause severe burns and permanent eye injury.
- Wear protective eye gear when handling or working near batteries.

Antidote (EXTERNAL) :

- SKIN – Flush with water.
- EYES – Flush with water for 15 minutes and get immediate medical attention.

Antidote (INTERNAL) :

- Drink large quantities of water or milk. Follow with milk of magnesia, beaten egg, or vegetable oil. Get immediate medical attention.

Batteries generate explosive hydrogen gas.

Always follow these preventive measures:

- Charge batteries in a well-ventilated area.
- Keep batteries away from fire, sparks, or open flames (e.g., welding equipment, lighted cigarettes, etc.)
- DO NOT SMOKE when charging or handling batteries.

KEEP BATTERIES AND ELECTROLYTE OUT OF REACH OF CHILDREN.

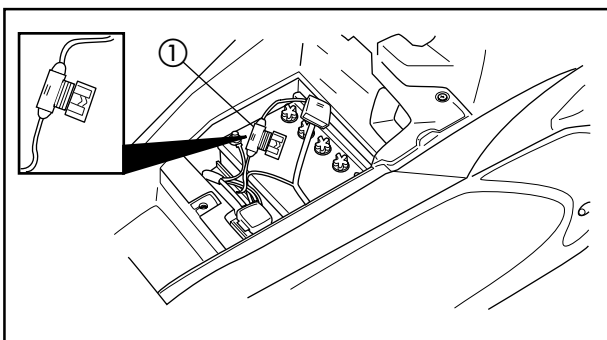

FUSE INSPECTION

1. Remove the battery cover.
2. Inspect :
 - Fuse ①
Blown → Replace.

FUSE INSPECTION/ HEADLIGHT BEAM ADJUSTMENT HEADLIGHT LENS REPLACEMENT



Fuse replacement steps :

- Turn off the ignition.
- Install a new fuse of the right amperage.
- Turn on the switches to verify the operation of the electric circuit.
- If the fuse immediately blows again, check the electric circuit.

WARNING

Never use a fuse with a rating higher than specified. An improper fuse may cause damage to the electrical circuit, and possibly cause a fire.

	Fuse : Main circuit : 7,5 A
---	--

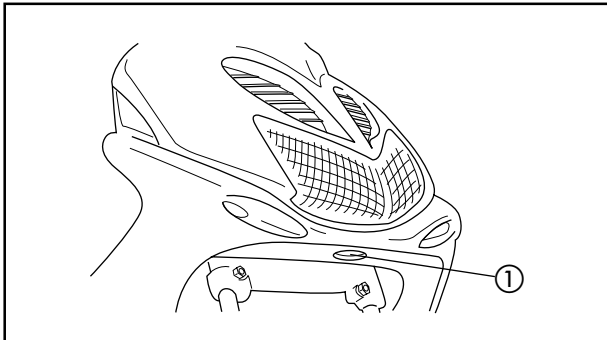

HEADLIGHT BEAM ADJUSTMENT

1. Adjust :
 - Headlight beam

Higher	Turn out screw ①
Lower	Turn in screw ②

HEADLIGHT LENS REPLACEMENT HEADLIGHT BULB REPLACEMENT

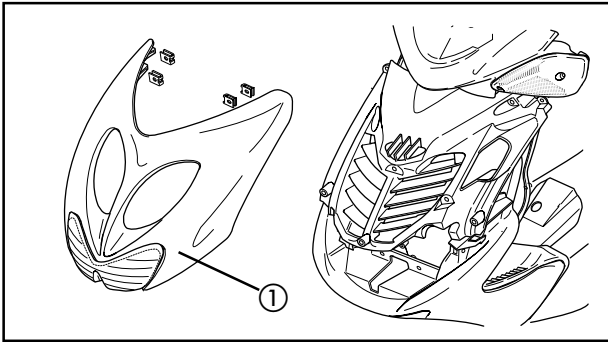
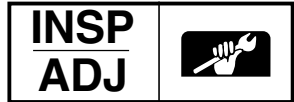

HEADLIGHT LENS REPLACEMENT

1. Remove :
 - Front cover ①

2. Remove :
 - Headlight lens
(Pull out the pins)

3. Remove :
 - Gasket

4. Install :
Reverse the "REMOVAL" procedure.

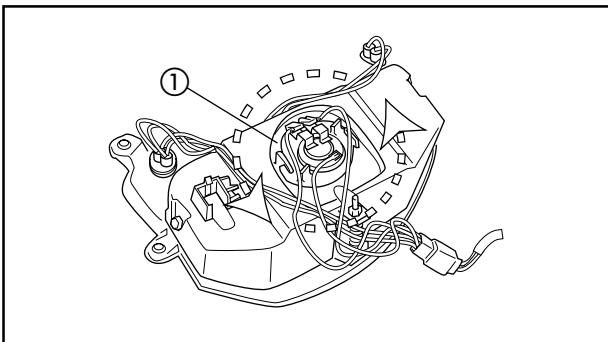

HEADLIGHT BULB REPLACEMENT

1. Remove :
 - Front cover

2. Remove :
 - Headlight bulb socket ①
(Turn one quart of a turn).

3. Remove :
 - Headlight bulb

4. Install :
Reverse the "REMOVAL" procedure.

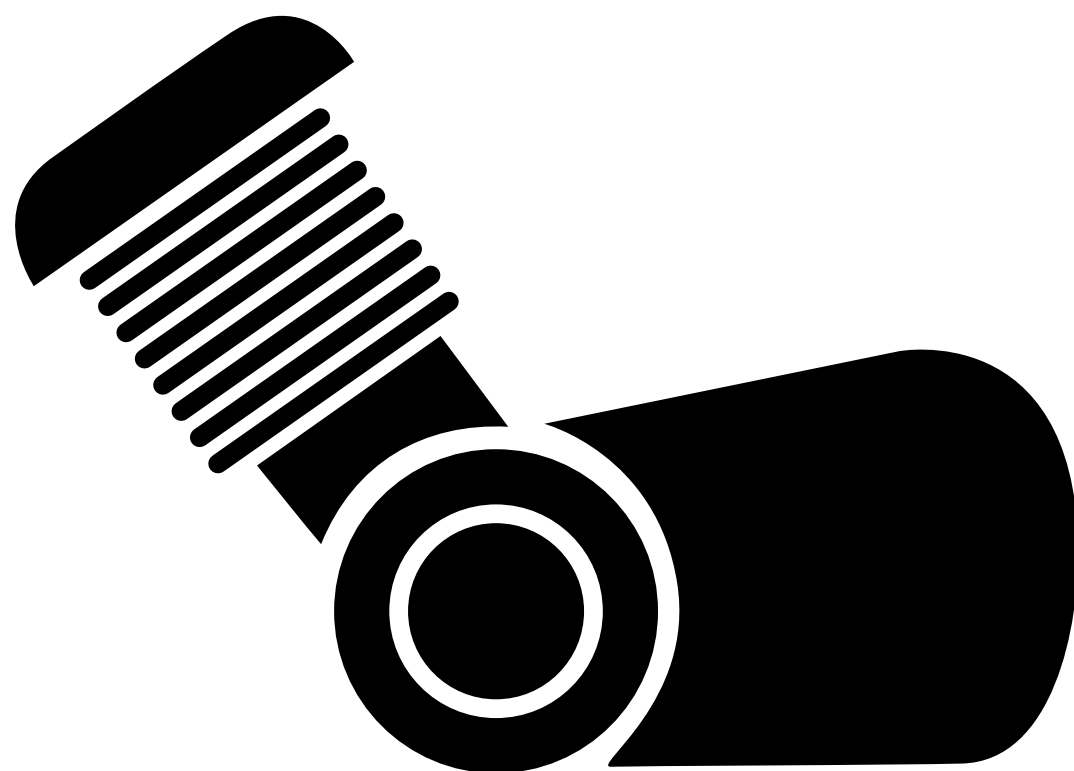

ENG

4



CHAPTER 4. ENGINE OVERHAUL

ENGINE REMOVAL	4-1
COVER REMOVAL	4-1
COOLING SYSTEM	4-1
CARBURETOR	4-1
CABLES, LEADS AND HOSES	4-2
ENGINE REMOVAL	4-3
ENGINE DISASSEMBLY	4-4
REAR WHEEL	4-4
CENTER STAND	4-4
CYLINDER HEAD AND CYLINDER	4-4
PISTON PIN AND PISTON	4-4
KICK STARTER	4-5
PRIMARY SHEAVE	4-6
SECONDARY SHEAVE	4-6
STARTER SYSTEM	4-7
TRANSMISSION	4-8
CDI MAGNETO	4-8
AUTOLUBE OIL PUMP	4-9
CRANKCASE AND CRANKSHAFT	4-9
INSPECTION AND REPAIR	4-11
CYLINDER HEAD	4-11
CYLINDER AND PISTON	4-11
PISTON RINGS	4-13
PISTON PIN AND PISTON PIN BEARING	4-14
KICK STARTER	4-15
TRANSMISSION	4-15
AUTOLUBE PUMP	4-16
CRANKSHAFT	4-16
PRIMARY SHEAVE	4-16
SECONDARY SHEAVE	4-17
V-BELT	4-18
STARTER CLUTCH AND GEARS	4-19
ENGINE ASSEMBLY AND ADJUSTMENT	4-20
CRANKSHAFT AND CRANKCASE	4-21
AUTOLUBE PUMP	4-23
CDI MAGNETO	4-24
TRANSMISSION	4-26
STARTER SYSTEM	4-27
PRIMARY SHEAVE	4-30
SECONDARY SHEAVE	4-30
KICK STARTER	4-31
PISTON PIN AND PISTON	4-36
CYLINDER AND CYLINDER HEAD	4-37
ENGINE REMOUNTING	4-39
COOLING SYSYEM	4-40



ENGINE OVERHAUL

ENGINE REMOVAL

COVER REMOVAL

1. Remove :

- Covers

See "CHAPTER 3 - SIDE COVERS AND FOOTREST BOARD - HANDLEBAR COVER".

COOLING SYSTEM

1. Drain:

- Coolant

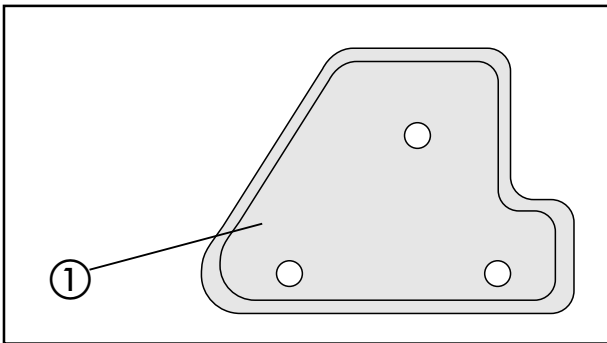

CARBURETOR

1. Remove :

- Air cleaner case assembly ①

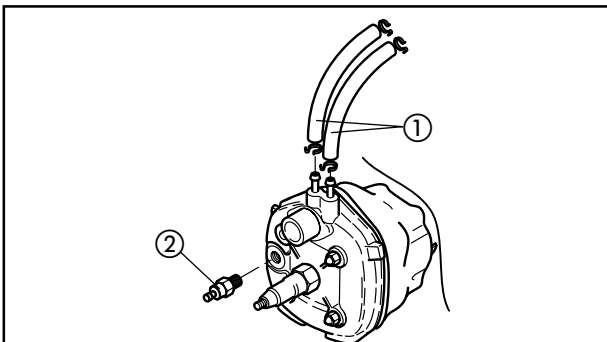

2. Disconnect :

- Carburetor cover
- Hoses
- Carburetor top
- Coolant hose ① on the cylinder head
- Thermostat ② on the cylinder head

3. Remove :

- Carburetor

4. Remove :

- Muffler assembly



5. Loosen :
 - Rear wheel fixing bolts

6. Remove:
 - Rear wheel

7. Loosen:
 - Rear wheel axle nut

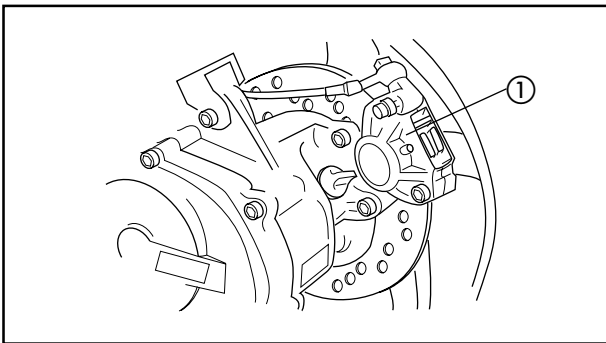

8. Remove:
 - Rear caliper ①
 - Rear wheel collar assembly

CABLES, LEADS AND HOSES

1. Remove :
 - Oil hose on the oil pump side

NOTE: _____
Plug the hose to prevent oil spillage.

2. Disconnect :
 - CDI unit lead pump side
 - Spark plug cap
 - Starter motor lead
 - Temperature sender lead on the cylinder head

ENGINE REMOVAL

ENG

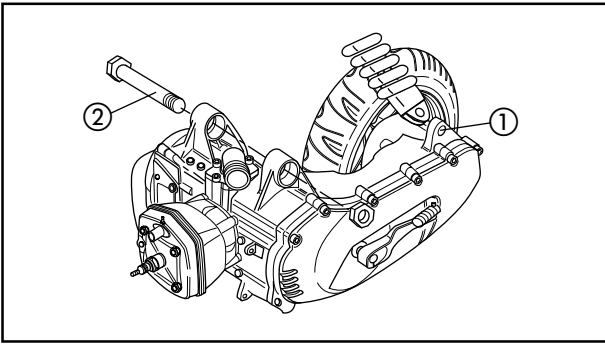

ENGINE REMOVAL

1. Place a suitable stand under the frame.

2. Remove :

- Rear shock absorber bolt (lower) ①
- Engine mounting bolt ②

3. Remove :

- Engine

NOTE:

Lift up the frame and remove the engine.

4. Place the frame on a suitable stand.



ENGINE DISASSEMBLY

REAR WHEEL

1. Remove :

- Rear wheel

Refer to chapter 7 "REAR WHEEL"

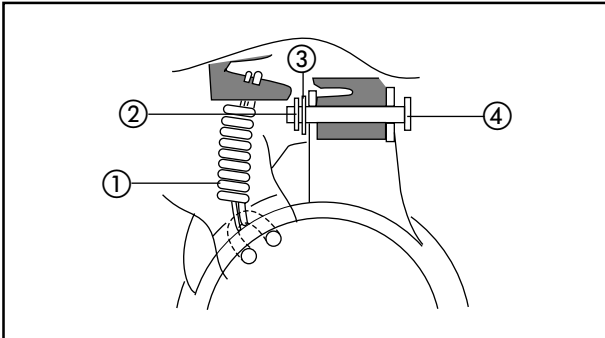

CENTERSTAND

1. Remove :

- Spring ①
- Clip ②
- Plate washer ③
- Axle ④
- Center stand

CYLINDER HEAD AND CYLINDER

1. Remove :

- Cylinder head
- Cylinder head gasket

NOTE:

- Before loosening the cylinder head nuts, loosen the spark plug.
- Loosen the cylinder head nuts crosswise 1/4 of a turn each before removing them.

2. Remove :

- Cylinder
- Cylinder gasket

PISTON PIN AND PISTON

1. Remove :

- Piston pin clip ①

NOTE:

Before removing the piston pin clip, cover the crankcase with a clean rag, so that the clip cannot accidentally fall into the crankcase.

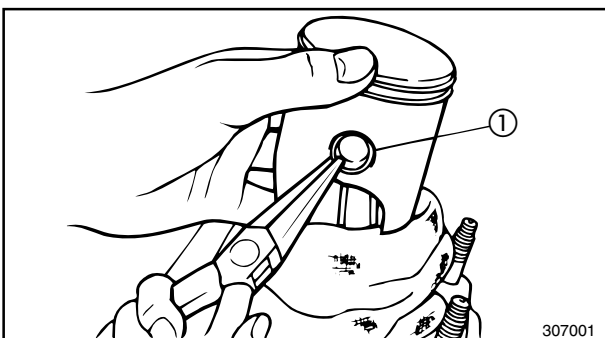

307001

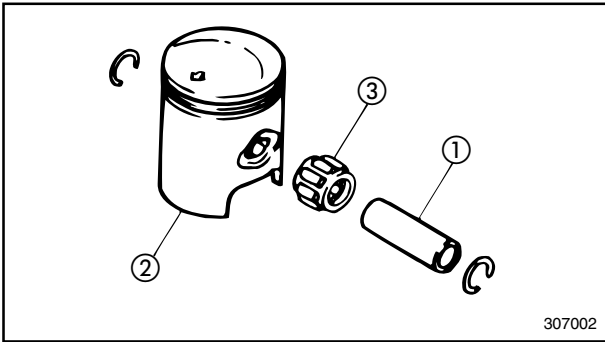

2. Remove :

- Piston pin ①
- Piston ②
- Piston pin bearing ③

CAUTION:

Do not use a hammer to drive out the piston pin.

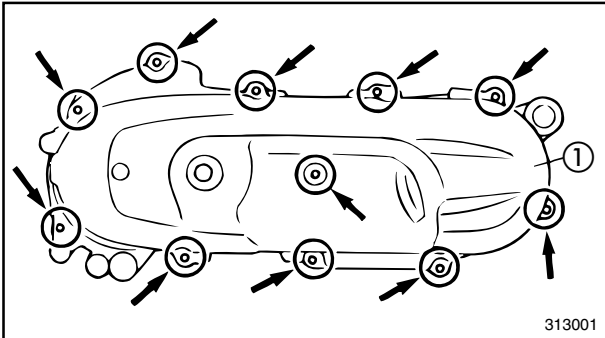

KICKSTARTER

1. Remove :

- Kick crank
- Transmission cover ① (left)

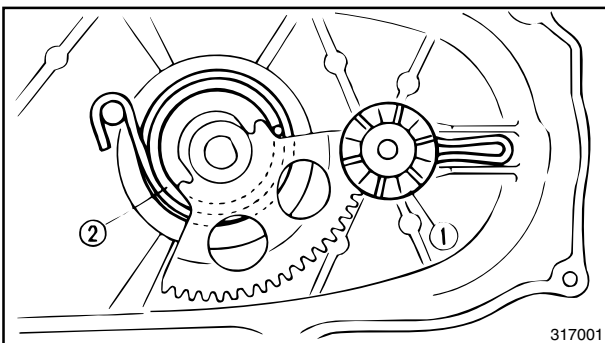

2. Remove :

- Kick pinion gear ①

NOTE:

To remove the kick pinion gear, push down the kick crank.

3 Unhook :

- Kick return spring ②

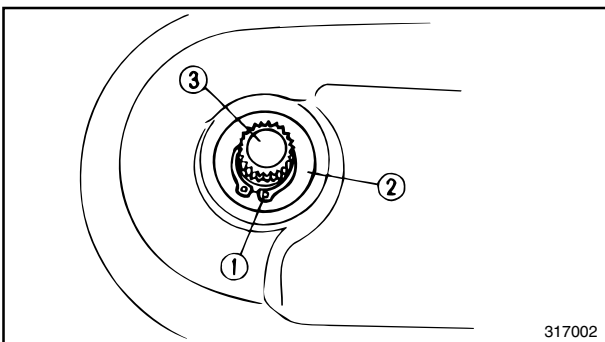

4. Remove :

- Circlips ①
- Plate washer ②
- Kick shaft ③



PRIMARY SHEAVE

1. Remove :
 - Oil pump housing
2. Remove :
 - Nut (primary sheave)

NOTE: _____

To loosen the primary sheave nut hold the CDI magneto with a flywheel holder ②.



Flywheel holder :
90890-01235

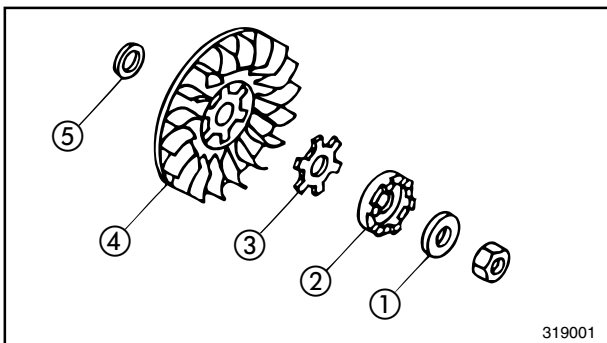

3. Remove :
 - Washer ①
 - Ratchet ②
 - Special washer ③
 - Fixed primary sheave ④
 - Washer ⑤
 - V-belt



4. Remove :
 - Spacer ①
 - Primary sliding sheave ②

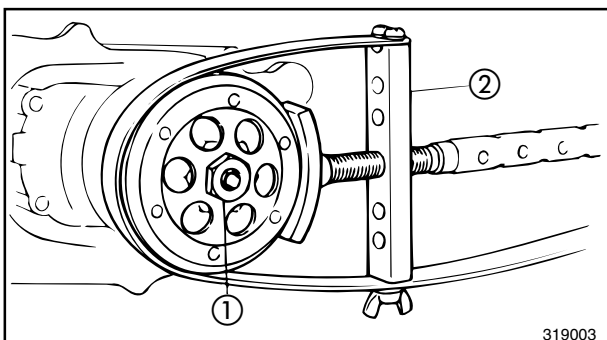

SECONDARY SHEAVE

1. Remove :
 - Nut ① (secondary sheave)

NOTE: _____

Hold the secondary sheave with a sheave holder ② to loosen the nut.



Sheave holder :
90890-01701

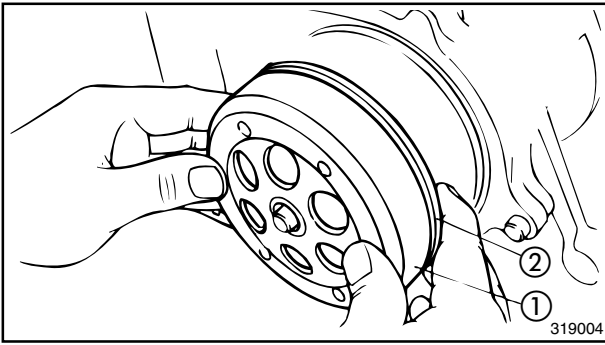

2. Remove :
- Clutch housing ①
 - Secondary sheave ②
 - Crankcase cover gasket
 - Dowel pins

3. Attach :
- Sheave holder ①
 - Nut wrench (41 mm)



Sheave holder :
90890-01701

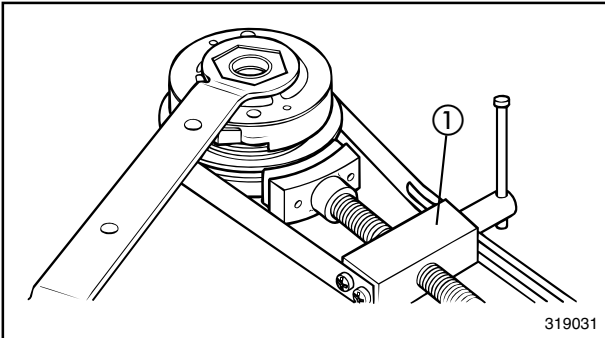

4. Loosen :
- Clutch securing nut

⚠ WARNING

Loosen the nut but do not remove it yet.

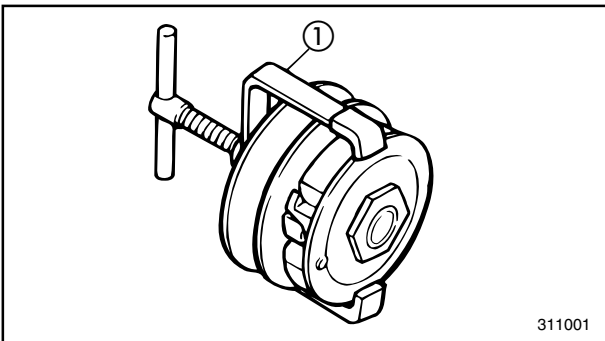

5. Attach :
- Clutch spring holder ①

NOTE:

Compress the secondary sheave using the clutch spring holder ①.



Clutch spring holder :
90890-01337

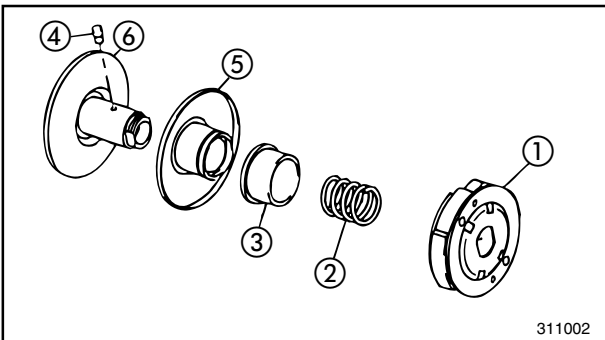

6. Remove :
- Clutch securing nut

7. Remove :
- Clutch assembly ①
 - Clutch spring ②
 - Spring seat ③
 - Guide pin ④
 - Secondary sliding sheave ⑤
 - Secondary fixed sheave ⑥

STARTER SYSTEM

1. Remove :
- Starter clutch assembly ①
 - Plate ② (idle gear)
 - Idle gear ③
 - Starter wheel gear ④
 - Spacer ⑤
 - Bearing ⑥
 - Washer ⑦

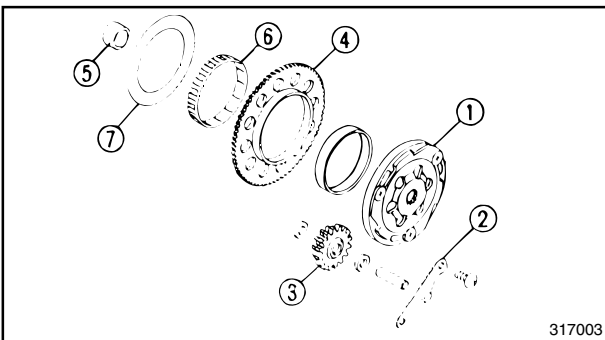

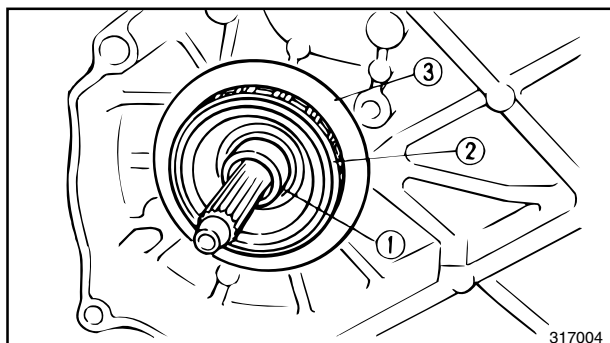

2. Remove :
- Spacer ①
 - Bearing ②
 - Washer ③
 - Starter motor

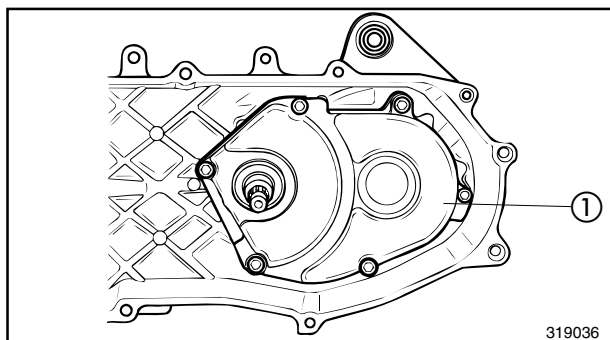

TRANSMISSION

1. Remove :
- Transmission case ①
 - Gasket
 - Dowel pins

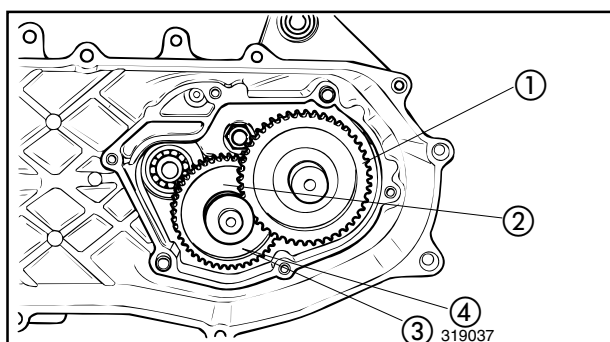

2. Remove :
- Main shaft ①
 - Drive shaft ②
 - Plate washer ③
 - Conical spring washer ④

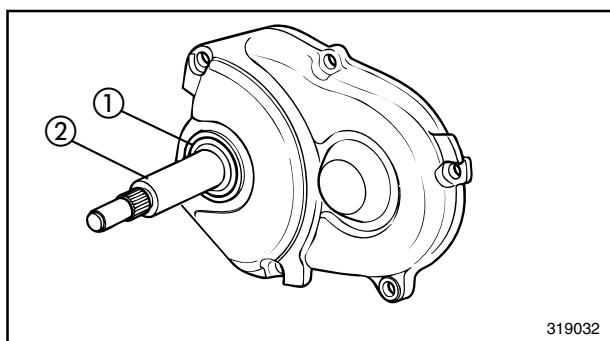

3. Remove :
- Oil seal ①
 - Secondary sheave axle ②

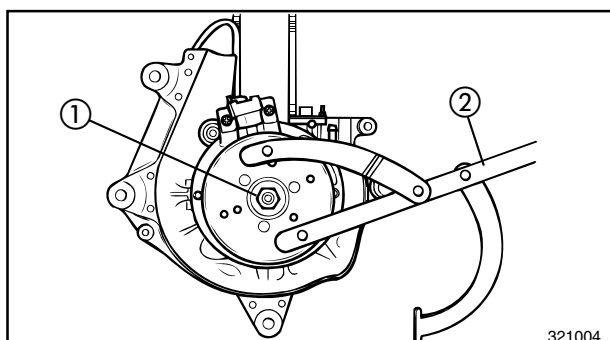

CDI MAGNETO

1. Remove :
- Nut ① (rotor)
 - Plate washer

NOTE: _____
 Hold the rotor using a flywheel holder ② to loosen the nut.



Flywheel holder :
90890-01235

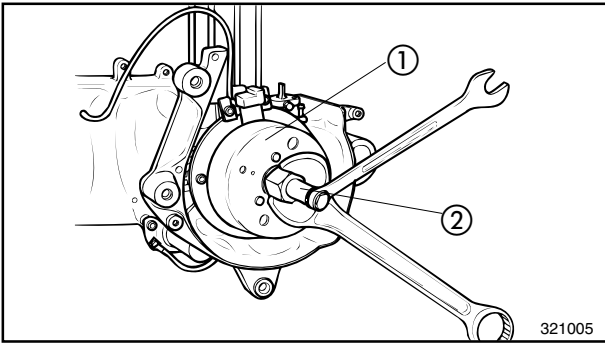

2. Remove :

- Rotor ①
- Woodruff key

Use the flywheel puller ②



Flywheel puller :
90890-01189

- Stator assembly
- Gasket

AUTOLUBE OIL PUMP

1. Remove :

- Autolube oil pump ①

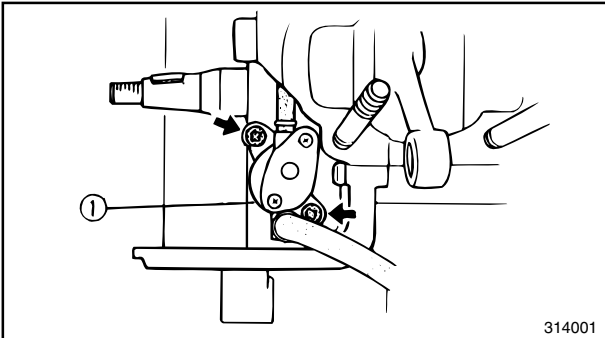

2. Remove :

- Circlips ①
- Pump drive gear ②
- Pin ③
- Circlip ④

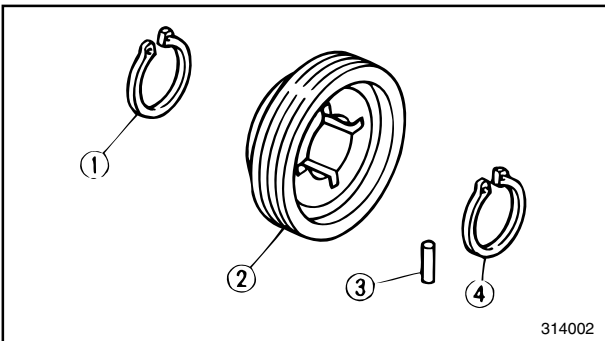

CRANKCASE AND CRANKSHAFT

1. Remove :

- Oil seal stopper ①
- Screws (crankcase)

NOTE: _____

Loosen each screw one quart of a turn before beginning to remove them.

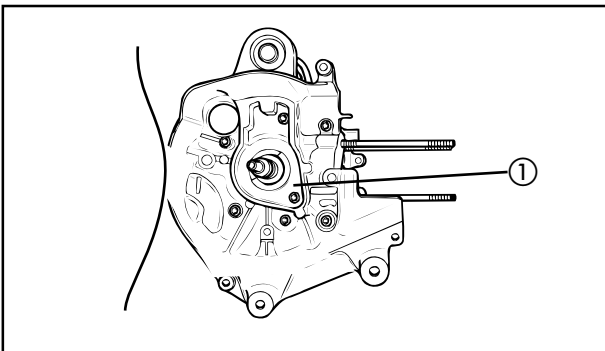

2. Attach :

- Crankcase separating tool ①



Crankcase separating tool :
90890-01135

NOTE: _____

Fully tighten the tool holding bolts. Insure that the tool body is parallel with the case. If necessary,

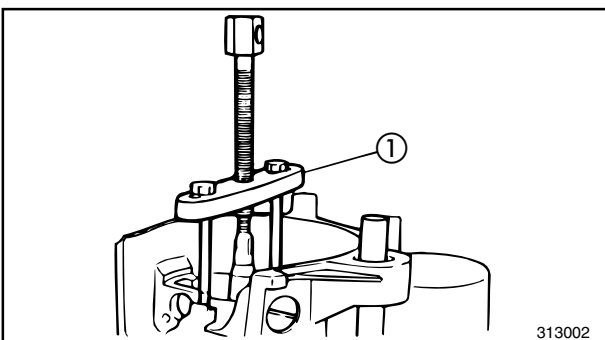



loosen one screw as much as required to level the tool body.

3. Remove :

- Crankcase (right)

As pressure is applied, keep tapping carefully on the engine mounting bosses.

CAUTION:

Use a soft hammer to tap on the case. Tap only on reinforced spots of the case. Never tap on the gasket mating surfaces. Work slowly and carefully. Make sure the cases separate evenly. If one end “hangs up” take the pressure off the push screw, realign the cases and the tool and start again. If the cases do not separate at all, check for a remaining case screw or fitting. Do not force.

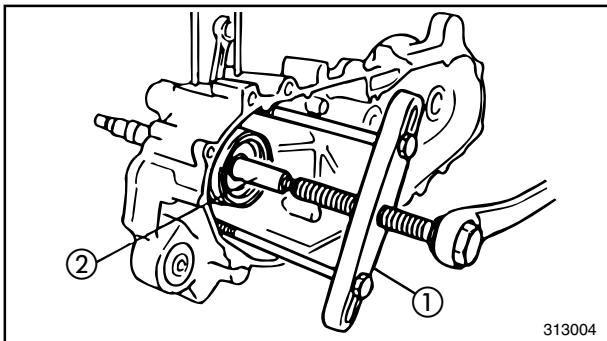

4. Attach :

- Crankcase separating tool ①



**Crankcase separating tool :
90890-01135**

5. Remove :

- Crankshaft ②

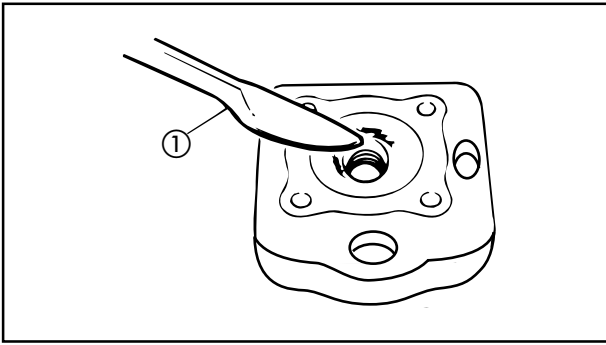

INSPECTION AND REPAIR

CYLINDER HEAD

1. Eliminate :
 - Carbon deposits
 Use a rounded scraper ①

NOTE: _____
 Take care to avoid damaging the spark plug threads. Do not use a sharp instrument. Avoid scratching the aluminum.

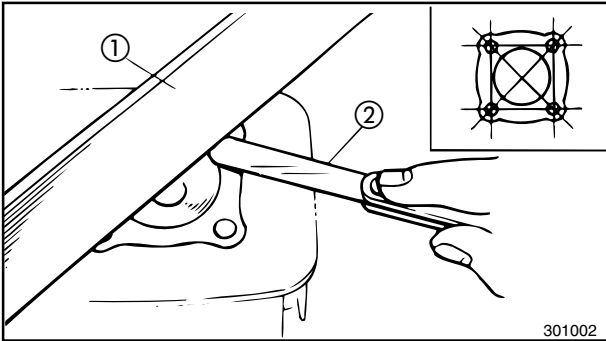

2. Inspect :
 - Cylinder head warpage
 Out of specification → Re-surface.

Warpage measurement and re-surfacement steps :

- Attach a straight edge ① and a thickness gauge ② to the cylinder head.
- Measure the warpage limit.

	Warpage limit : 0.02 mm (0.0078 in)
--	--

- If the warpage is out of specification, re-surface the cylinder head.

NOTE: _____
 Rotate the head several times to avoid removing too much material from one side.

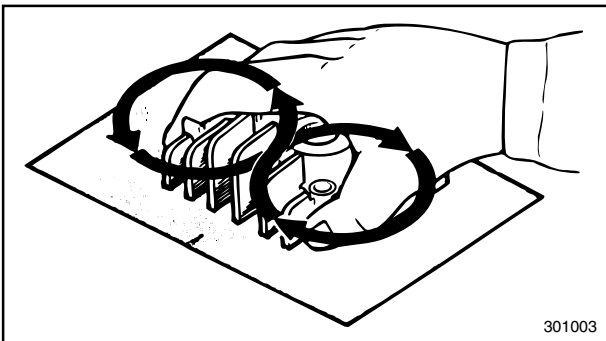

CYLINDER AND PISTON

1. Eliminate :
 - Carbon deposits
 Use a rounded scraper ①

2. Inspect :
 - Cylinder wall
 Wear/Scratches → Replace.

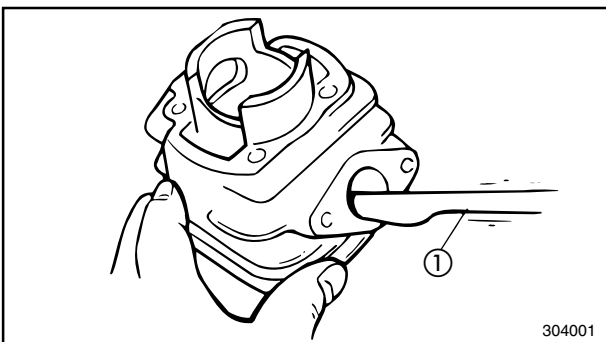

3. Eliminate :
 - Carbon deposits
 From the piston crown ① and ring grooves ②.

4. Remove :
 - Score marks and lacquer deposits
 From the sides of piston.

NOTE: _____
 Sand in a crisscross pattern. Do not sand excessively.

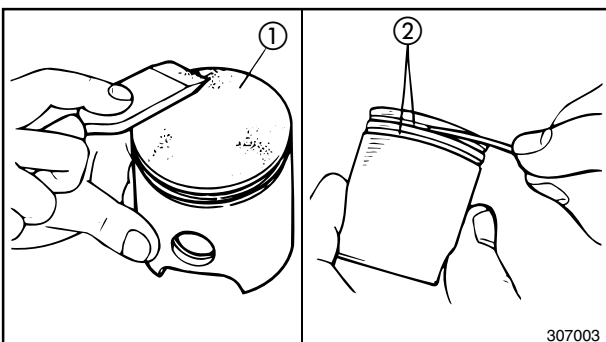

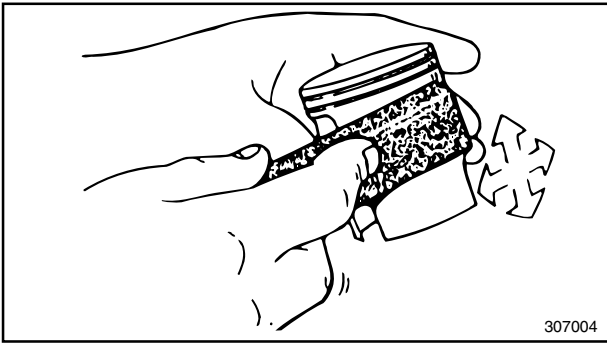

307004

5. Inspect :
- Piston wall
Wear/Scratches/Damage → Replace.

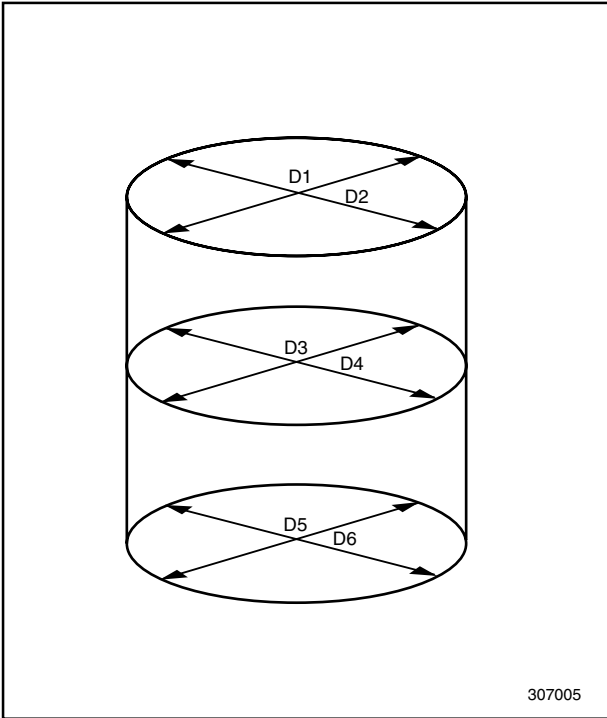

307005

6. Measure :
- Piston to cylinder clearance

Piston to cylinder clearance measurement steps :

First step :

- Measure the cylinder bore “C” with a cylinder bore gauge.

NOTE:

Measure the cylinder bore “C” in parallel to and at right angles to the crankshaft. Then, calculate the average of the measurements.

	Standard	Wear limit
Cylinder Bore “C”	39.99 ~ 40.01mm (1.574 ~ 1.575 in)	40.10 mm (1.579 in)
Taper “T”	—	0,05mm (0.0019 in)
C = Maximum D T = (Maximum D₁,D₃ or D₅) - (Maximum D₂,D₄ or D₆)		

- If out of specification, replace cylinder, piston and piston rings as a set.

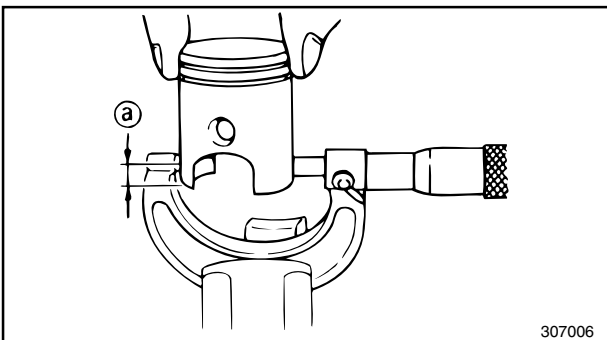

307006

2nd step :

- Measure the piston skirt diameter “P” with a micrometer.
@ 5 mm (0.20 in) from the piston bottom edge.

	Piston Size : Standard : 39.957 ~ 39.977 mm (1.5731 ~ 1.5738 in)
---	---

- If out of specification, replace piston and piston rings as a set.

3rd step :

- Calculate the piston-to-cylinder clearance with following formula:

**Piston-to cylinder clearance =
Cylinder Bore "C" –
Piston Skirt Diameter "P"**

- If out of specification, replace cylinder, piston and piston rings as a set.

Piston-to-cylinder clearance :
0.029 ~ 0.042 mm
(0.0011 ~ 0.0016 in)
Wear limit : 0.1 mm (0.004 in)

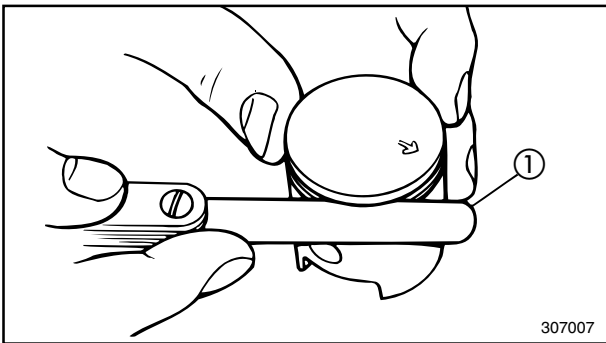

PISTON RINGS

1. Measure :

- Side clearance
Out of specification → Replace piston and/or rings.

Use a Feeler Gauge ①

	Standard	Limit
Top ring	0.03 ~ 0.05 mm (0.0012 ~ 0.0020 in)	0.10 mm (0.004 in)
2nd ring	0.03 ~ 0.05 mm (0.0012 ~ 0.0020 in)	0.10 mm (0.004 in)

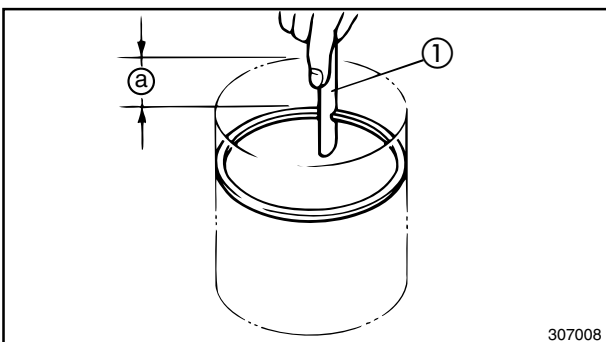

2. Install :

- Piston ring
 - Into the cylinder
- Push the ring with the piston crown.

3. Measure :

- End gap
Out of specification → Replace rings as a set.
- Use a Feeler Gauge ①



	Standard	Limit
Top ring	0.15 ~ 0.30 mm (0.005 ~ 0.011 in)	0.70 mm (0.028 in)
2nd ring	0.15 ~ 0.30 mm (0.005 ~ 0.011 in)	0.70 mm (0.028 in)

@ Measuring Point 20 mm (0.8 in)

PISTON PIN AND PISTON PIN BEARING

1. Inspect :

- Piston pin
Blue discoloration/Groove → Replace, then inspect lubrication system.

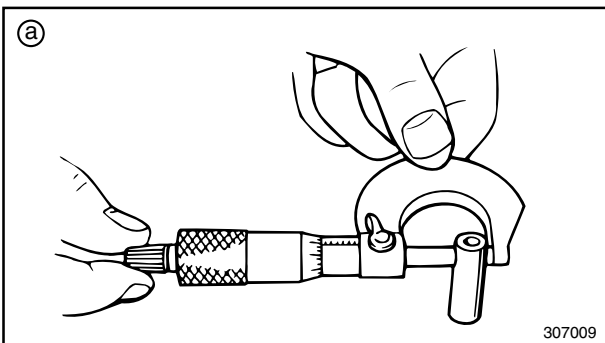

2. Measure :

- Outside diameter (piston pin)
Out of specification → Replace.

	Outside diameter (piston pin) :
	9.996 ~ 10.000 mm (0.3935 ~ 0.3937 in)

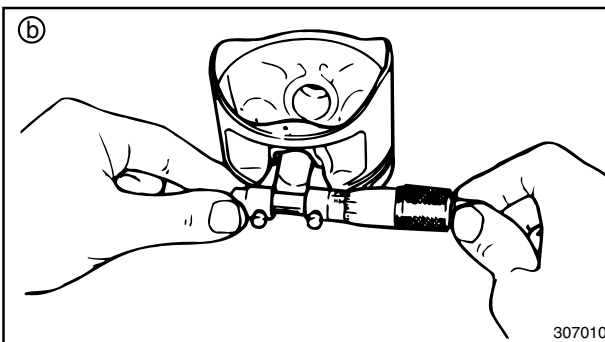

3. Measure :

- Piston pin-to-piston clearance
Out of specification → Replace piston.

Piston pin-to-piston clearance = Bore (piston pin) b - Outside diameter (piston pin) a

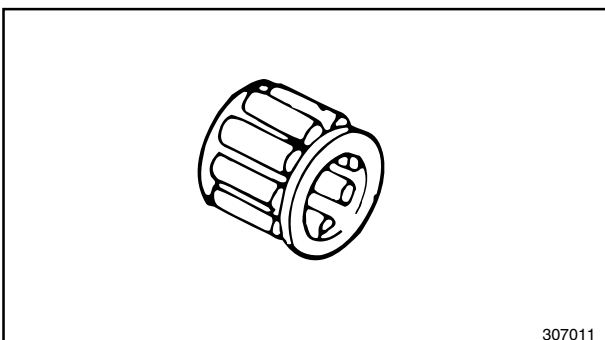

	Piston pin-to-piston clearance :
	0.004 ~ 0.019 mm (0.0002 ~ 0.0008 in) <Limit : 0.07 mm (0.028 in)>

4. Inspect :

- Bearing (piston pin)
Pitting/Damage → Replace

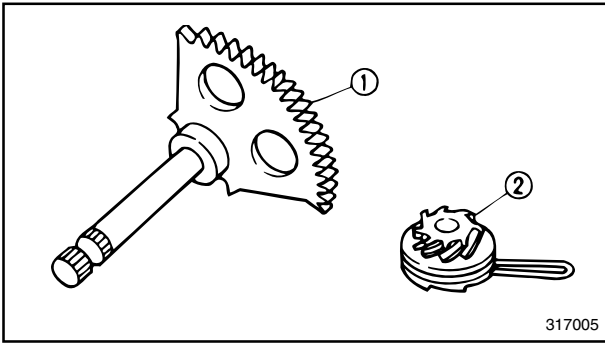

KICK STARTER

1. Inspect :

- Kick gear teeth ①
- Kick pinion gear teeth ②
Burrs/Chips/Roughness/Wear → Replace.

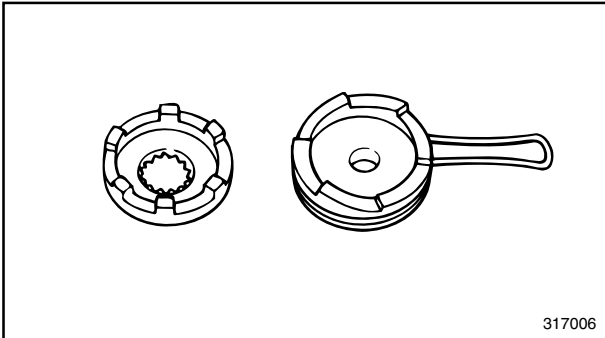

2. Inspect :

- Mating dogs (kick pinion gear and one-way clutch)
Rounded edges/Damage → Replace.

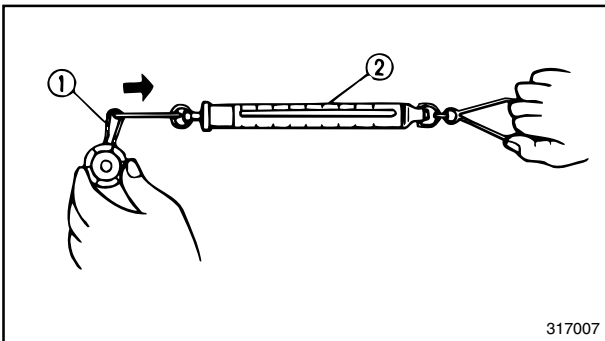

3. Measure :

- Clip tension (kick pinion gear) ①
Out of specification → Replace.
Use a spring balance ②.



Standard tension :
150 ~ 250 g (5.3 ~ 8.8 oz.)

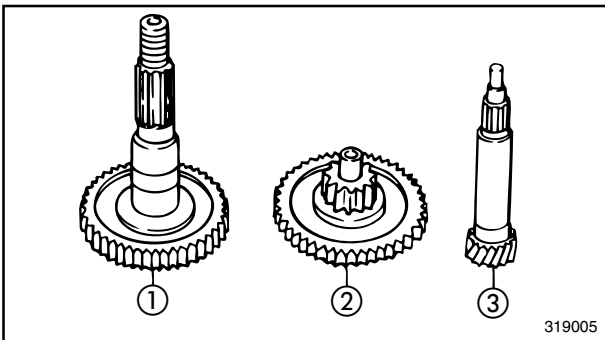

TRANSMISSION

1. Inspect :

- Drive axle ①
- Main axle ②
- Secondary sheave axle ③
Burrs/Chips/Roughness/Wear → Replace.

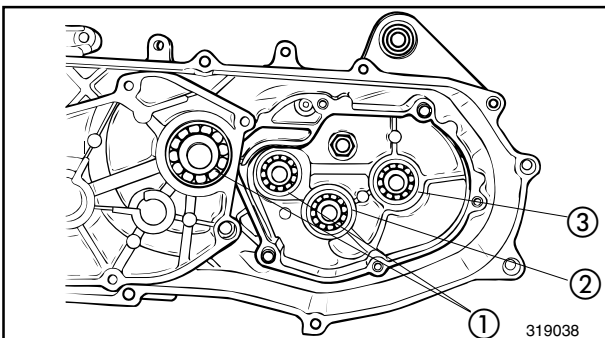

2. Inspect :

- Secondary sheave axle bearing ①
 - Main axle bearing ②
 - Drive axle bearing ③
- Spin the bearing inner race.
Excessive play/Roughness → Replace.
Pitting/Damage → Replace.



AUTOLUBE PUMP

Wear or an internal malfunction may cause the pump output to vary from the factory setting. This situation is, however, extremely rare. If improper output is suspected, inspect the following:

1. Inspect :
 - Delivery line
Obstructions → Blow out.
 - O-ring
Wear/Damage → Replace.

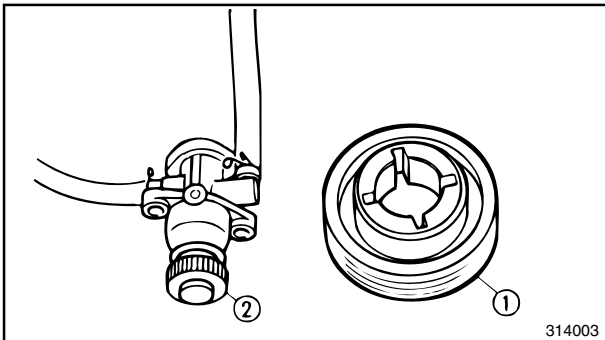

2. Inspect :
 - Autolube pump drive gear teeth ①
 - Autolube pump driven gear teeth ②
Pitting/Wear/Damage → Replace.

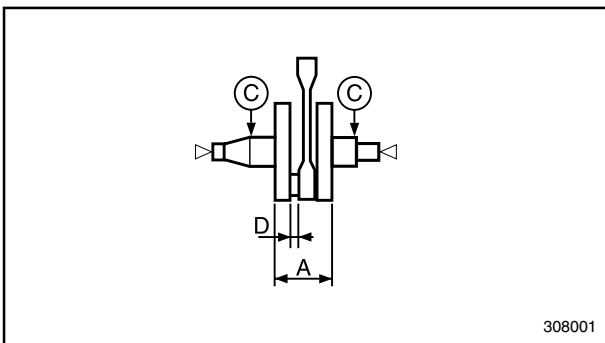

CRANKSHAFT

1. Measure :
 - Crankshaft width "A"
 - Runout limit "C"
 - Connecting rod big end side clearance "D"
 Use V-blocks, dial gauge and thickness gauge.

	Crankshaft width "A" :
	37.90 ~ 37.95 mm (1.492 ~ 1.494 in)
	Runout limit "C" :
	0.03 mm (0.0012 in)
	Connecting rod big end side clearance "D" :
	0.2 ~ 0.5 mm (0.008 ~ 0.02 in)

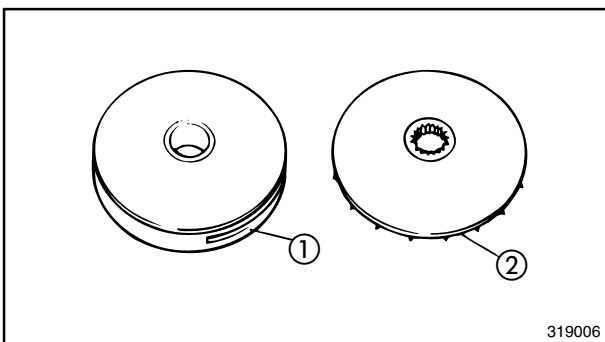

PRIMARY SHEAVE

1. Inspect :
 - Primary sliding sheave ①
 - Primary fixed sheave ②
Wear/Cracks/Scratch/Damage → Replace.

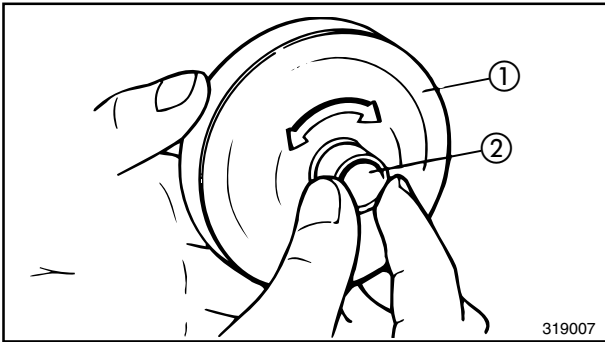

2. Check :

- Free movement

Insert the collar (2) into the primary sliding sheave (1), and check for free movement.

Stick or excessive play → Replace the sheave and/or collar.

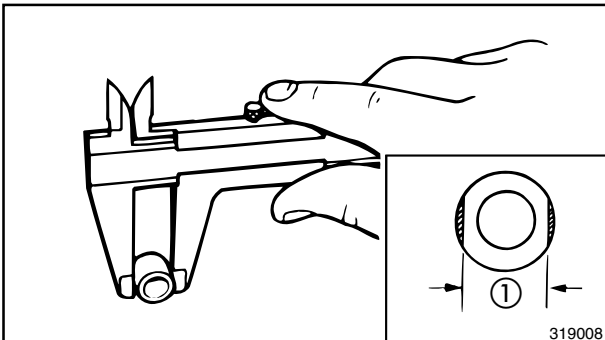

3. Measure :

- Outside diameter (1) (weight)

Out of specification → Replace.



Outside diameter (weight) :
15.0 mm (0.59 in)
<Limit>:
14.5 mm (0.57 in)>

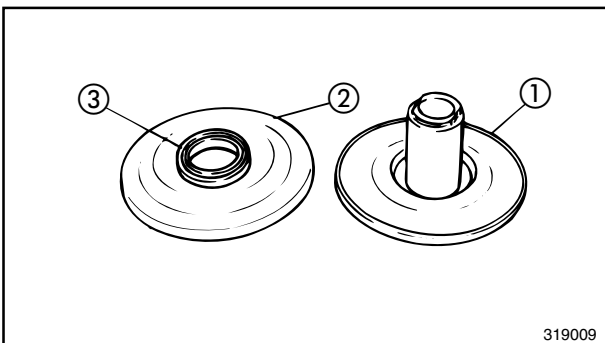

SECONDARY SHEAVE

1. Inspect :

- Secondary fixed sheave (1)

- Secondary sliding sheave (2)

Scratch/Crack/Damage → Replace as a set.

- Oil seal (3)

Damage → Replace.

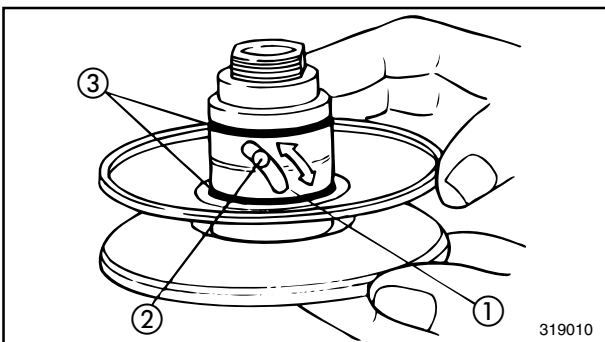

2. Inspect :

- Torque cam groove (1)

- Guide pin (2)

Wear/Damage → Replace as a set.

- O-rings (3)

Damage → Replace.

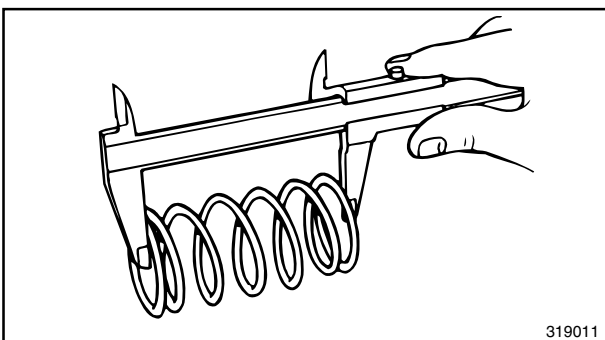

3. Measure :

- Clutch spring free length

Out of specification → Replace.



Clutch spring free length :
121.7 mm (4.79 in)
<Limit> :
106.7 mm (4.20 in)

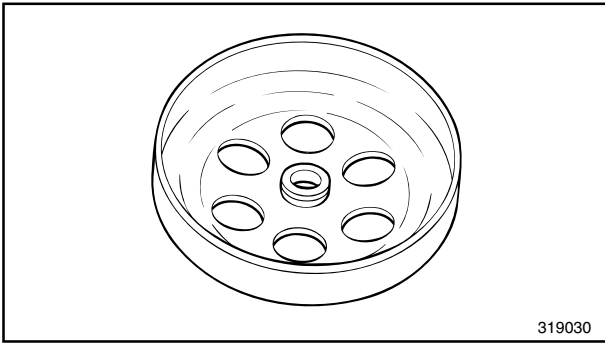

4. Inspect :
- Clutch housing inner surface
Oil/Scratches → Remove.

Oil	Use a rag soaked in lacquer thinner or solvent.
Scratches	Use an emery cloth (lightly and evenly polishing).

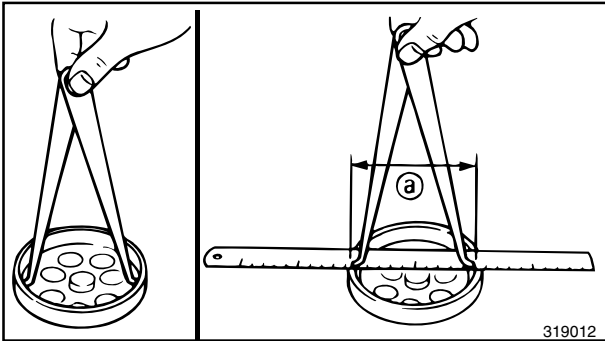

5. Measure :
- Clutch housing inside diameter @
Out of specification → Replace.

	Clutch housing inside diameter :
	107.0 mm (4.21 in)
	<Wear Limit> :
	107.4 mm (4.22 in)

6. Inspect :
- Clutch shoes
Glazed parts → Sand with coarse sandpaper.

NOTE: _____
After using the sand paper, clean off the polished particles with a cloth.

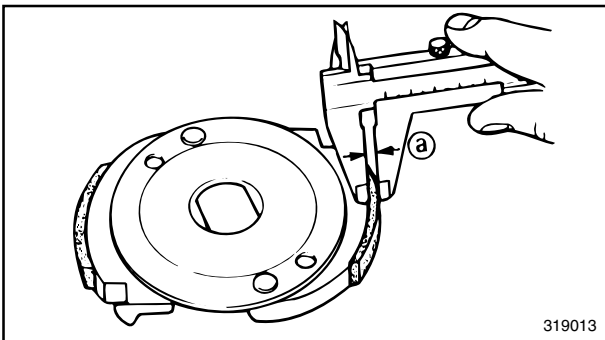

7. Measure :
- Clutch shoe thickness @
Out of specification → Replace.

	Clutch shoe thickness :
	2.0 mm (0.07 in)
	<Wear Limit> :
	1 mm (0.03 in)

V-BELT

1. Inspect :
- V-belt
Crack/Wear → Replace.

NOTE: _____
Replace the V-belt if it is greasy or oily.

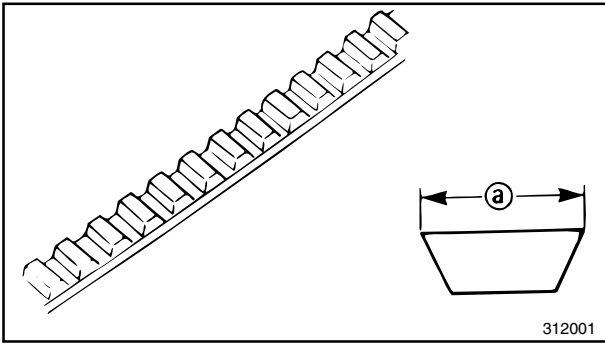

2. Measure :
- V-belt width @
- Out of specification → Replace.

	V-Belt width :
	16,5 mm (0.65 in)
	<Wear Limit> :
	15,7 mm (0.62 in)

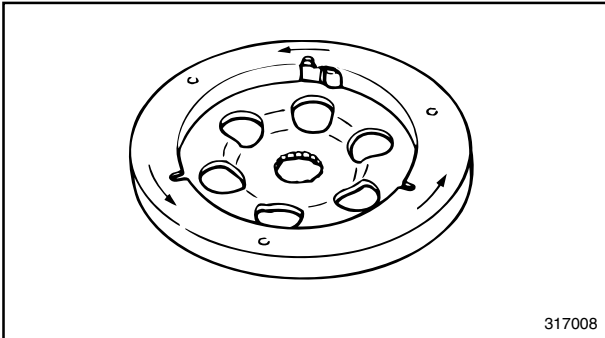

STARTER CLUTCH AND GEARS

1. Inspect :
- Starter clutch
- Push the dowel pin in arrow direction.
- Unsmooth operation → Replace starter clutch assembly.

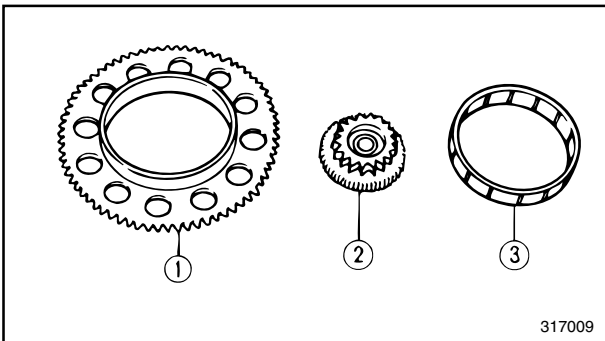

2. Inspect :
- Starter wheel gear teeth ①
 - Idle gear teeth ②
- Burrs/Chips/Roughness/Wear → Replace.
- Bearing ③ (starter wheel gear)
- Pitting/Damage → Replace.



CRANKSHAFT AND CRANKCASE

- ① Oil seal
- ② Oil seal holder
- ③ Crankcase (right)
- ④ Dowel pin
- ⑤ Bearing
- ⑥ Crankshaft (right)
- ⑦ Bearing
- ⑧ Crankshaft pin
- ⑨ Connecting rod
- ⑩ Crankshaft (left)
- ⑪ Bearing
- ⑫ Engine mount shaft
- ⑬ Crankcase (left)
- ⑭ Oil seal

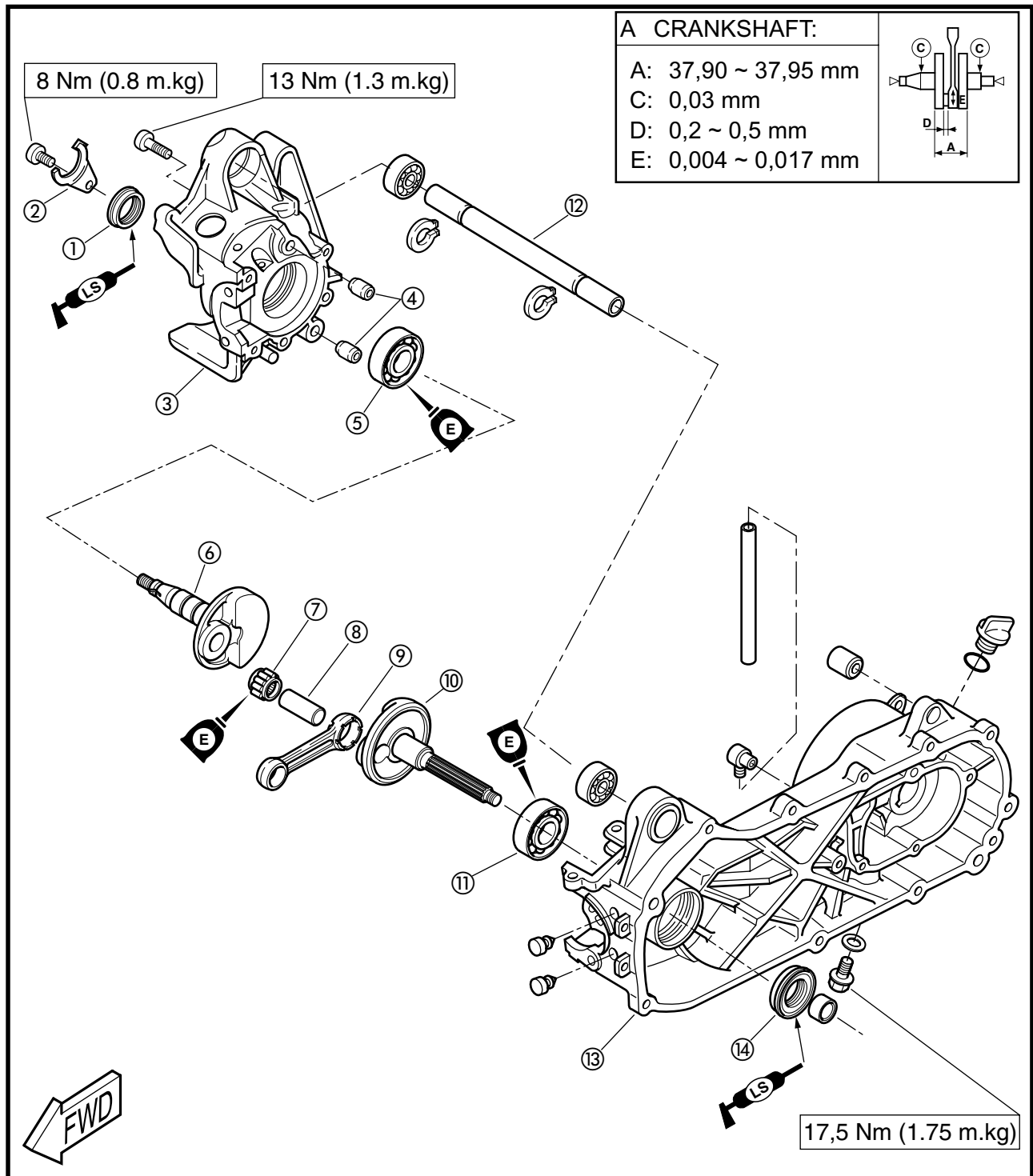



CRANKSHAFT AND CRANKCASE

CAUTION:

To protect the crankshaft against scratches and to facilitate the engine assembly and installation, apply grease to oil seal lips, and engine oil to bearings.

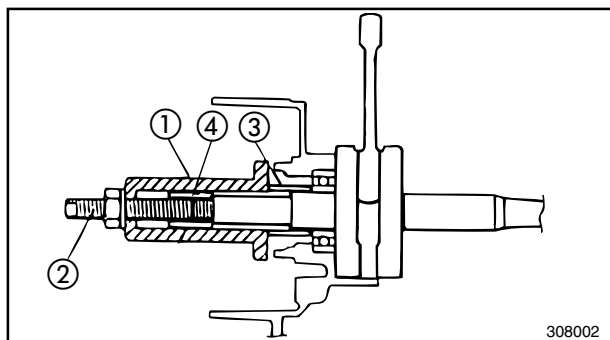

1. Attach :

- Crankshaft installation tool ①, ②, ③, ④

	Crankshaft installation tool :
	① : 90890-01274
	② : 90890-01275
	③ : 90890-01277
	④ : 90890-01411

2. Install :

- Crankshaft
(to left crankcase)

NOTE:

Hold the connecting rod at top dead center with one hand while tightening the nut of the installation tool with the other. Tighten the installation tool until the crankshaft bottoms against the bearing.

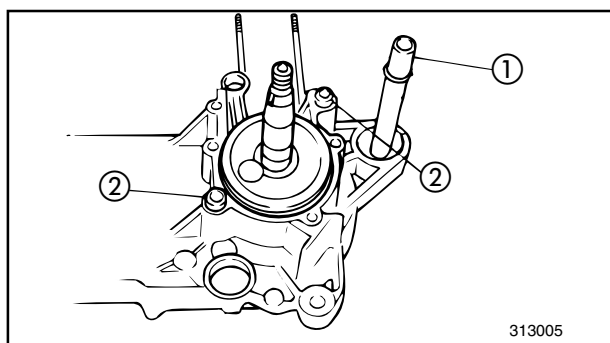

3. Install :

- Dowel pins ①
- Spacer ②

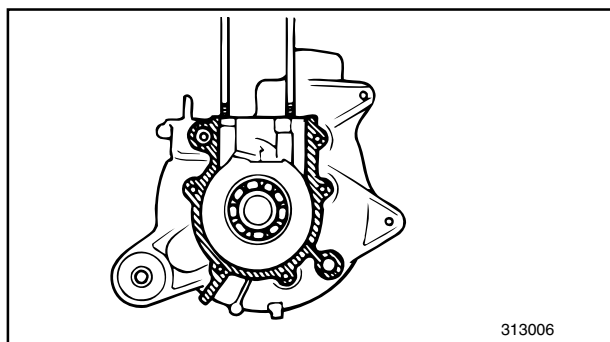

4. Apply :

- HEATPROOF or Yamaha Bond No.1215
To the mating surfaces of both case halves.

	HEATPROOF or Yamaha Bond No.1215
--	---

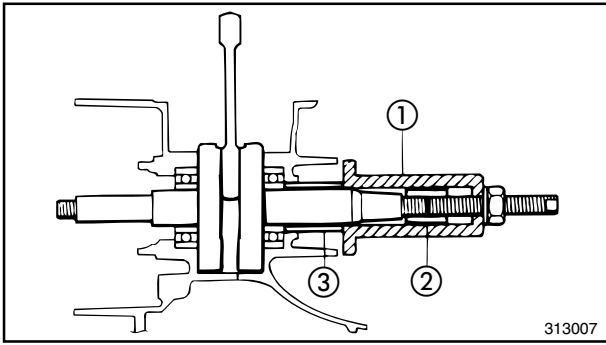

5. Attach :

- Crankshaft installation tool ①, ②, ③, ④



Crankshaft installation tool :

- ① : 90890-01274
- ② : 90890-01275
- ③ : 90890-01277
- ④ : 90890-01411

NOTE: _____

Hold the connecting rod at top dead center with one hand while tightening the nut of the installation tool with the other. Tighten the installation tool until the crankcase halves close with one another.

6. Install :

- Right crankcase

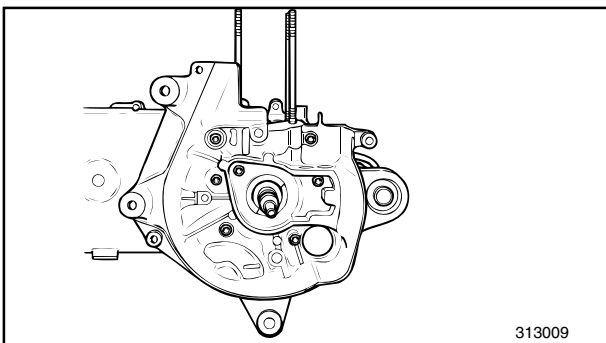

7. Tighten :

- Crankcase holding screws

NOTE: _____

Tighten the crankcase holding screws in stages, using a crisscross pattern.



Crankcase holding screw :
15 Nm (1,5 m.kg)

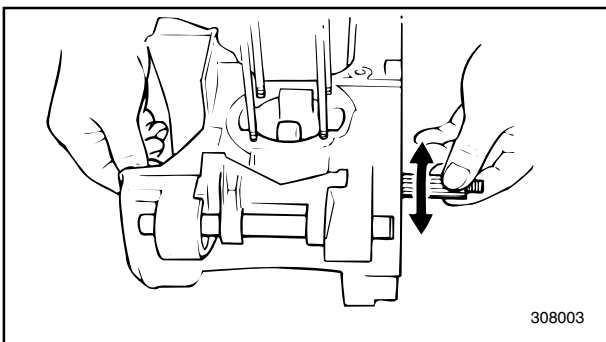

8. Check :

- Crankshaft operation
Unsmooth operation → Repair.

CAUTION: _____

Never hit on the crankshaft.

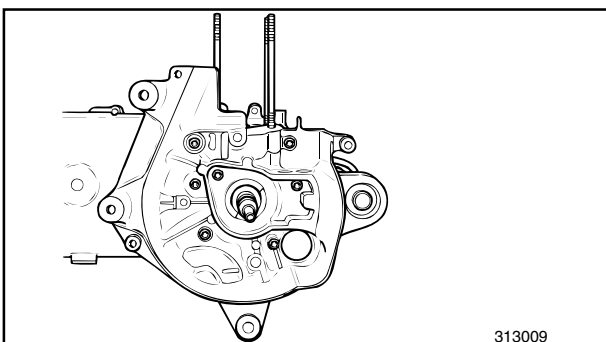

9. Install :

- Oil seal stopper plate



Screw (oil seal stopper plate) :
8 Nm (0.8 m.kg)



AUTOLUBE PUMP AND CDI MAGNETO

- | | |
|-------------------|-----------------------|
| ① Nut | ⑨ Gasket |
| ② Plain washer | ⑩ Oil hose |
| ③ Rotor assembly | ⑪ Oil delivery hose |
| ④ Lighting coil | ⑫ Clip |
| ⑤ Charge coil | ⑬ Autolube pump |
| ⑥ Pick up coil | ⑭ O-ring |
| ⑦ Stator assembly | ⑮ Circlip |
| ⑧ Oil seal | ⑯ Oil pump drive gear |

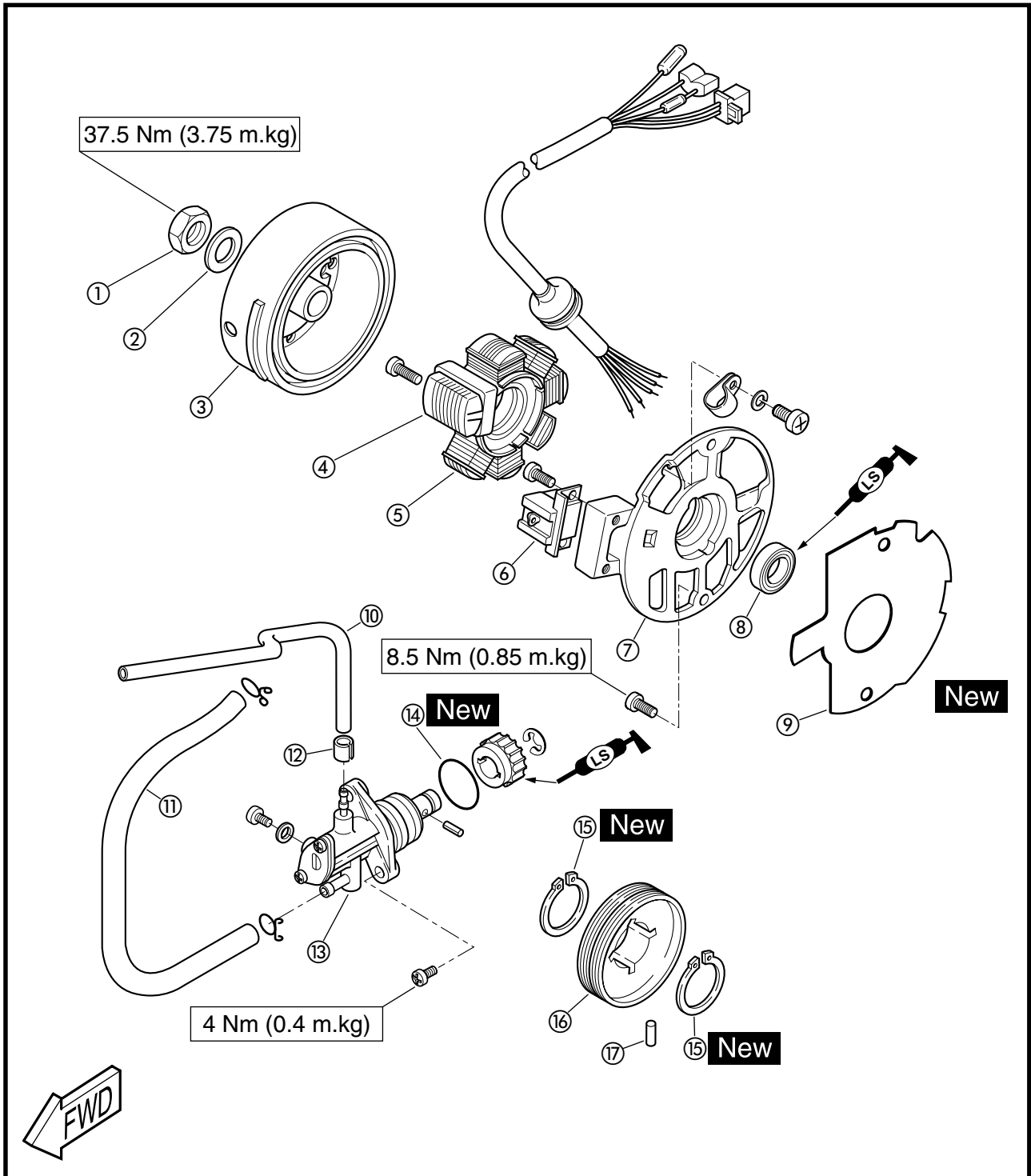

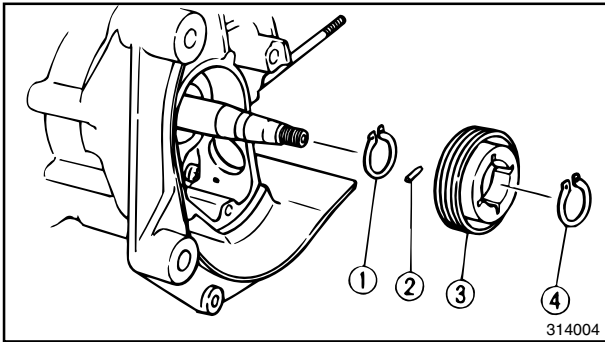

AUTOLUBE PUMP

1. Install :
 - Circlip ①
 - Pin ②
 - Pump drive gear ③
 - Circlip ④

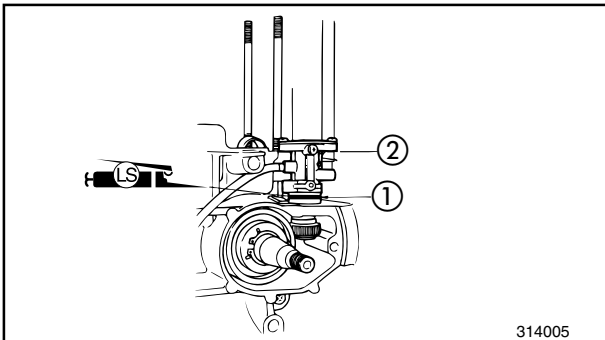

2. Apply :
 - Lithium soap base grease
(to O-ring)

3. Install :
 - Autolube pump



Screw (autolube pump) :
4 Nm (0.4 m.kg)

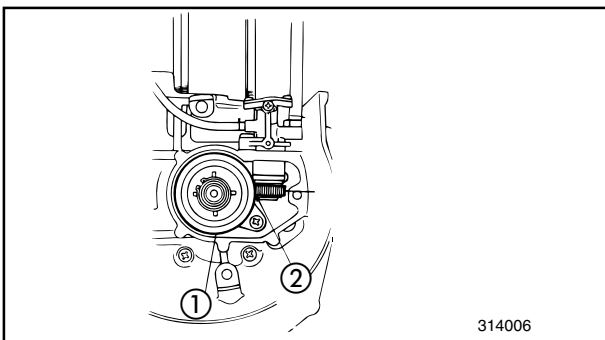

4. Apply :
 - Lithium soap base grease
(to autolube pump gear)



Lithium soap base grease :
15 cc (0.92 cu.in)

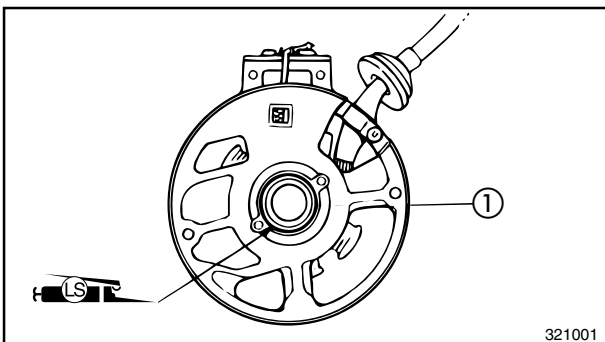

CDI MAGNETO

1. Install :
 - Gasket
2. Apply :
 - Lithium soap base grease
(to oil seal ①)

3. Pass the CDI magneto lead through the crankcase hole.

4. Install :
 - Stator assembly



Screw (stator assembly) :
8,5 Nm (0.85 m.kg)

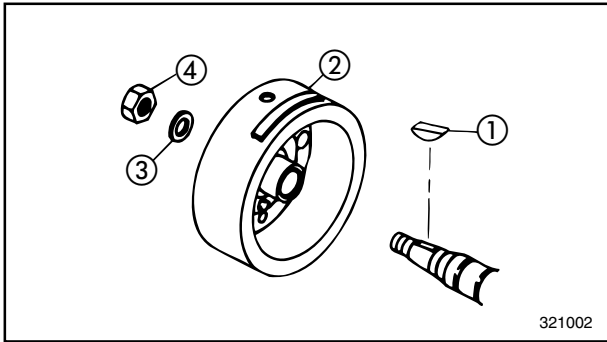

5. Install :

- Woodruff key ①
- Magneto rotor ②
- Plain washer ③
- Nut ④

NOTE: _____

When installing the magneto rotor, make sure the woodruff key is properly seated in the key way of the crankshaft. Apply a light coating of lithium soap base grease to the tapered portion of the crankshaft end.

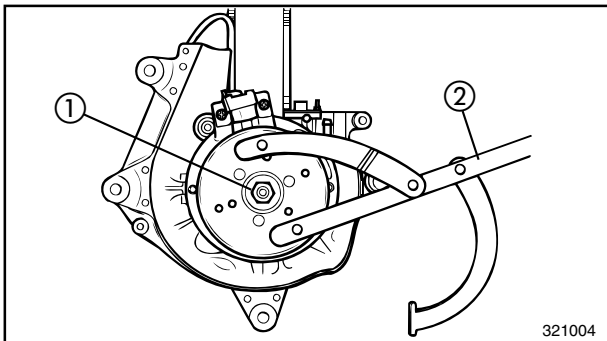

6. Tighten :

- Nut ① (magneto rotor)
- Use the flywheel holding tool ②.



Flywheel holding tool :
90890-01235



Nut (Flywheel magneto) :
37,5 Nm (3.75 m.kg)



TRANSMISSION

- | | |
|-------------------------|---------------------------|
| ① Circlip | ⑨ Secondary sheave axle |
| ② Bearing | ⑩ Bearing |
| ③ Oil seal | ⑪ Dowel pin |
| ④ Drive axle | ⑫ Gasket |
| ⑤ Bearing | ⑬ Transmission case cover |
| ⑥ Main axle | ⑭ Circlips |
| ⑦ Conical spring washer | ⑮ Oil seal |
| ⑧ Plain washer | |

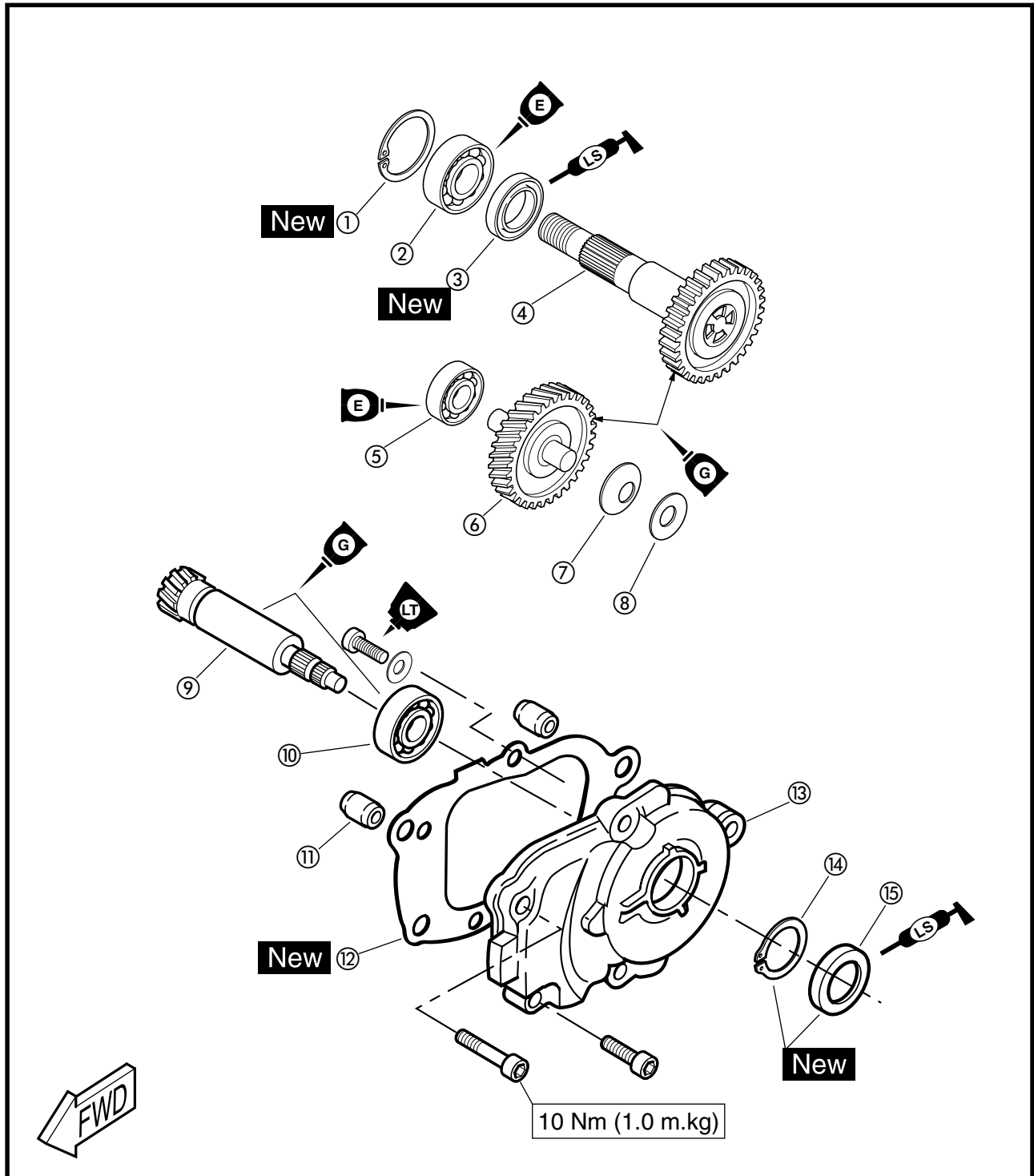



TRANSMISSION

1. Apply :
 - 10W30 Type SE Motor oil
(to transmission case cover bearing)

2. Install :
 - Bearing ①

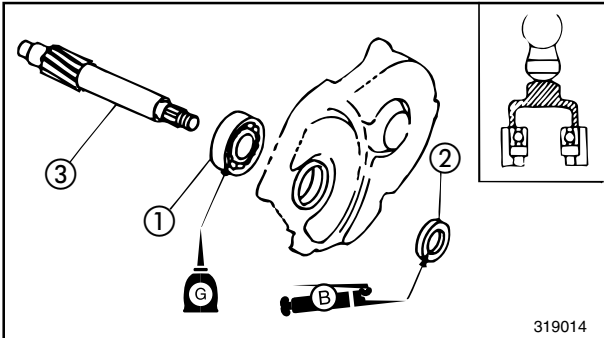

3. Install :
 - Oil seal ②
 - Secondary sheave axle ③

NOTE: _____
Apply lithium soap base grease onto the oil seal lips.

4. Check :
 - Secondary sheave axle operation
Unsmooth operation → Repair.

5. Apply :
 - 10W30 type SE Motor oil
(to main axle bearing and drive axle bearing)

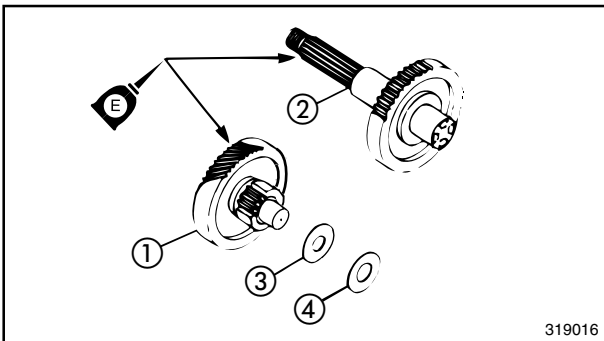

6. Install :
 - Drive axle ①
 - Main axle ②
 - Conical spring washer ③
 - Plain washer ④

NOTE: _____
• Apply lithium soap base grease onto the oil seal lips.
• Always use a new gasket.

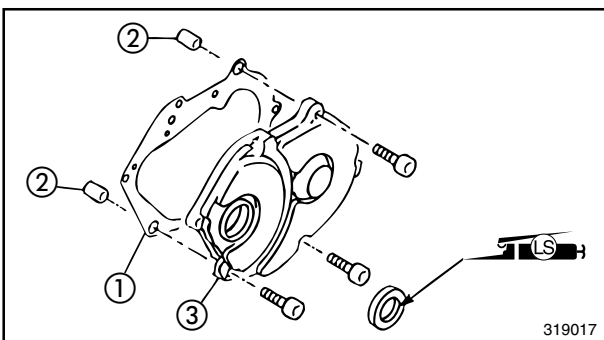

7. Install :
 - Gasket ①
 - Dowel pins ②
 - Transmission case cover ③



Screw (case cover):
10 Nm (1.0 m.kg)

STARTER SYSTEM

- ① Collar
- ② Starter wheel gear
- ③ Bearing
- ④ Starter clutch
- ⑤ Plate
- ⑥ Shaft
- ⑦ Washer
- ⑧ Idle gear
- ⑨ O-Ring
- ⑩ Starter motor

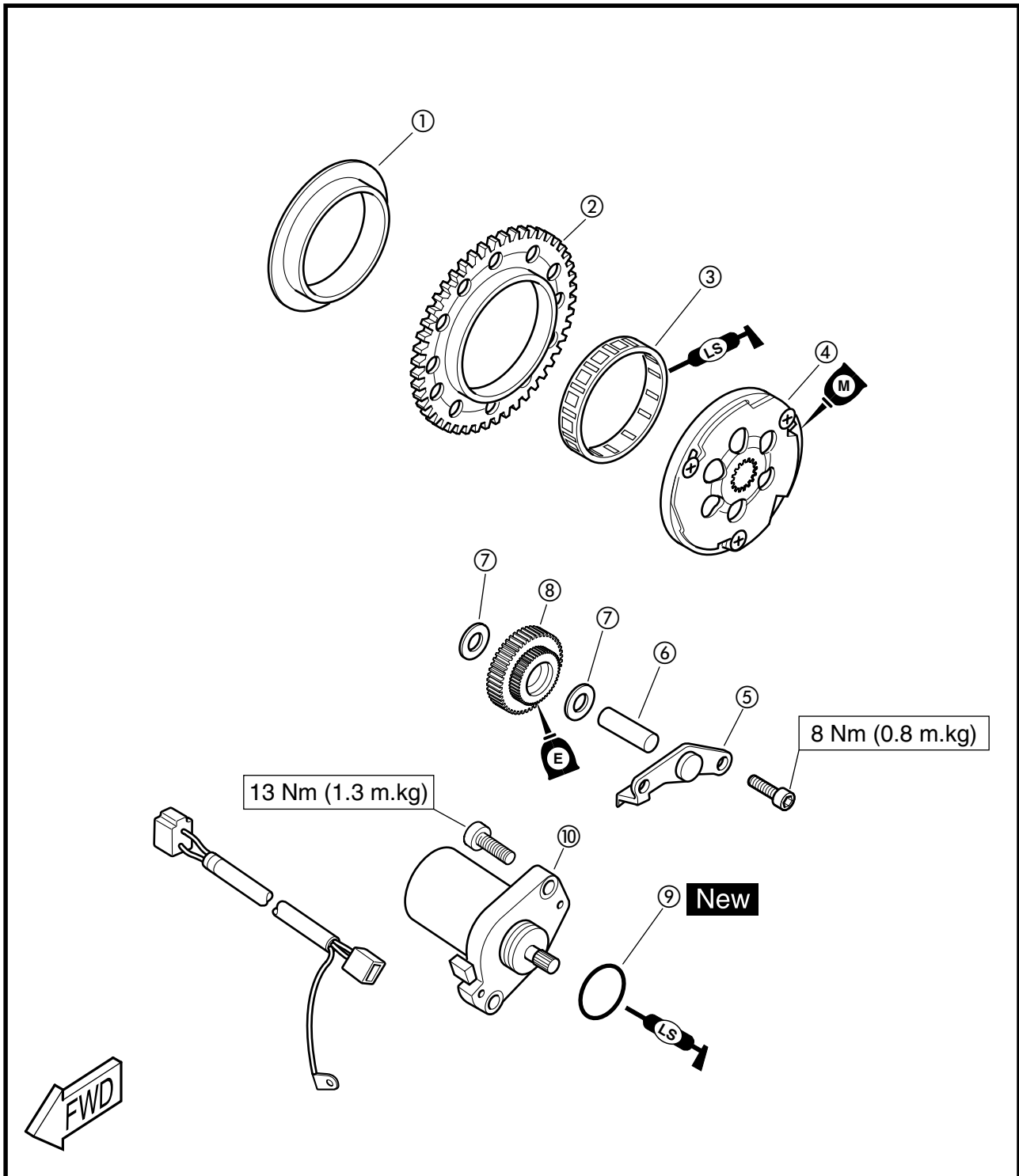

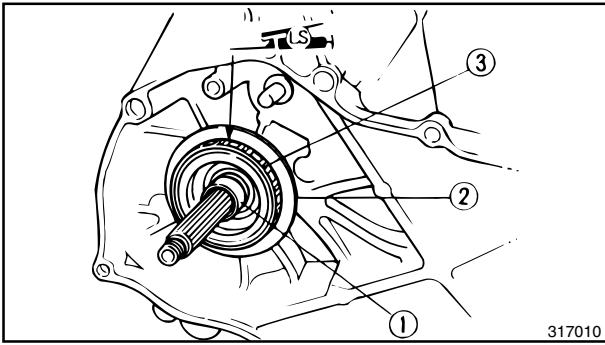

317010

STARTER SYSTEM

1. Install :

- Collar ①
- Washer ②
- Bearing ③
- Starter wheel gear ④
- Starter clutch ⑤

NOTE:

- Apply lithium soap base grease to the bearing.
- Apply molybdenum disulfide oil to the shaft (starter clutch).

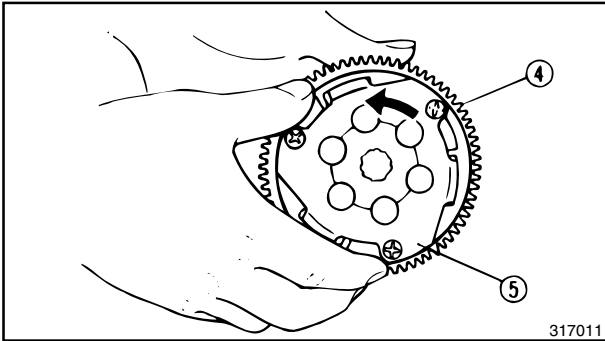

317011

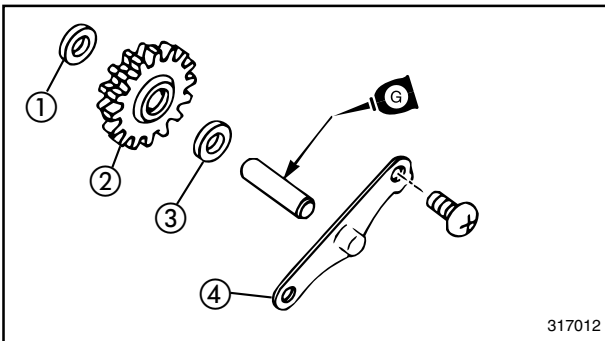

317012

2. Install :

- Plain washer ①
- Idle gear ②
- Plain washer ③
- Plate ④ (idle gear)



Screw (idle gear plate) :
8 Nm (0.8 m.kg)

NOTE:

Apply engine oil to the idle gear ②.

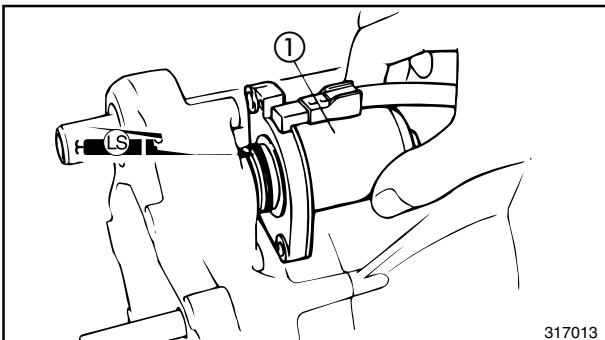

317013

3. Install :

- Starter motor ①



Screw (starter motor) :
13 Nm (1.3 m.kg)

NOTE:

Apply lithium soap base grease to the O-ring of the starter motor.



PRIMARY AND SECONDARY SHEAVE

- | | |
|----------------------------|--------------------------|
| ① Nut | ⑫ Secondary fixed sheave |
| ② Clutch housing | ⑬ Conical washer |
| ③ Clutch | ⑭ One-way clutch |
| ④ Clutch spring | ⑮ Special washer |
| ⑤ Spring | ⑯ Primary fixed sheave |
| ⑥ Spring seat | ⑰ Washer |
| ⑦ Oil seal | ⑱ Spacer |
| ⑧ O-Ring | ⑲ Primary sliding sheave |
| ⑨ Secondary sliding sheave | ⑳ Clutch weights |
| ⑩ V-Belt | ㉑ Slider |
| ⑪ Guide pin | ㉒ Came |

*Apply BEL-RAY Assembly Lube[®]

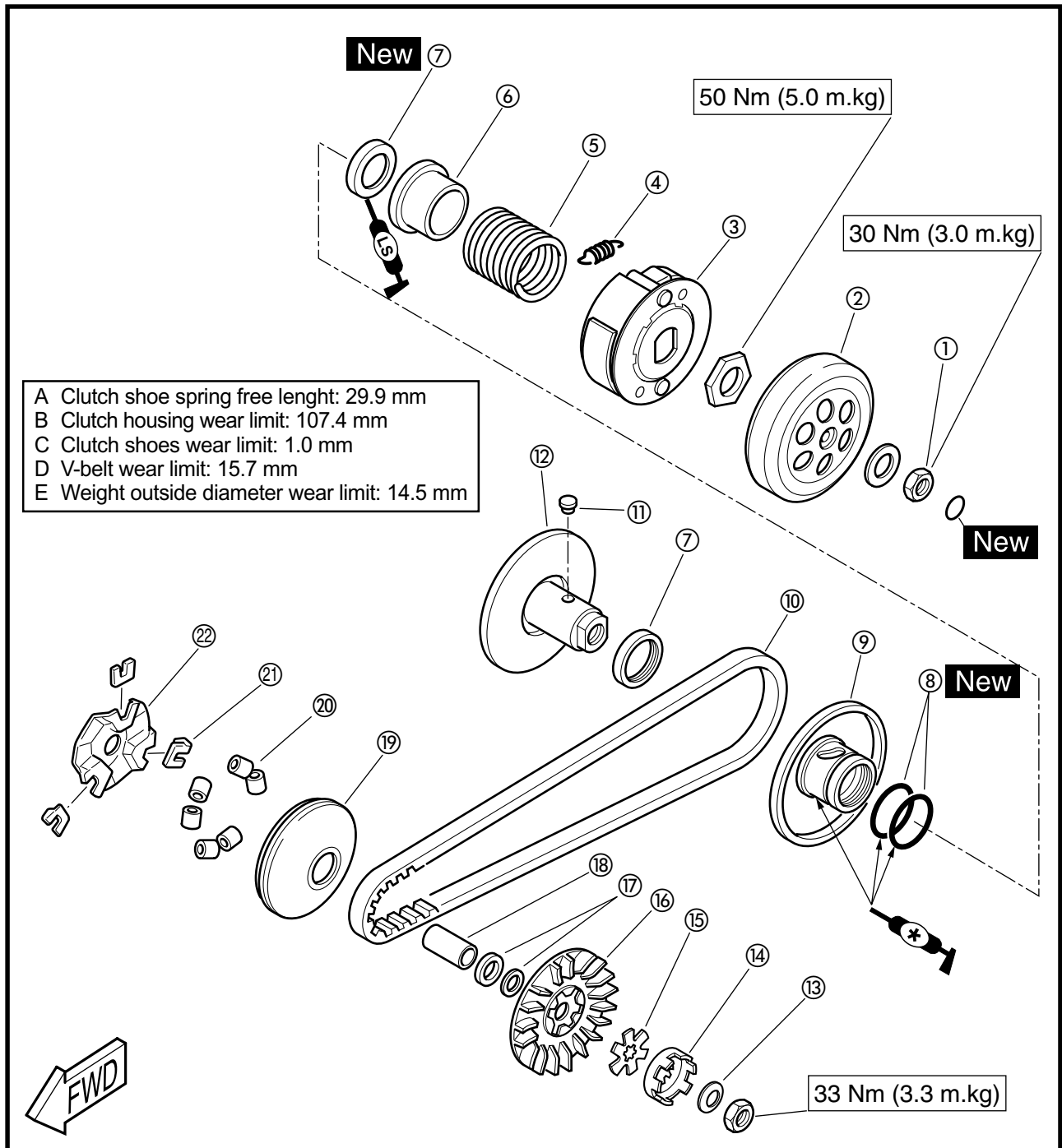



KICK STARTER

- ① Kick shaft
- ② Return spring
- ③ Collar
- ④ Gasket
- ⑤ Transmission case
- ⑥ Washer
- ⑦ Circlips
- ⑧ Kick crank
- ⑨ Kick clip
- ⑩ Ratchet

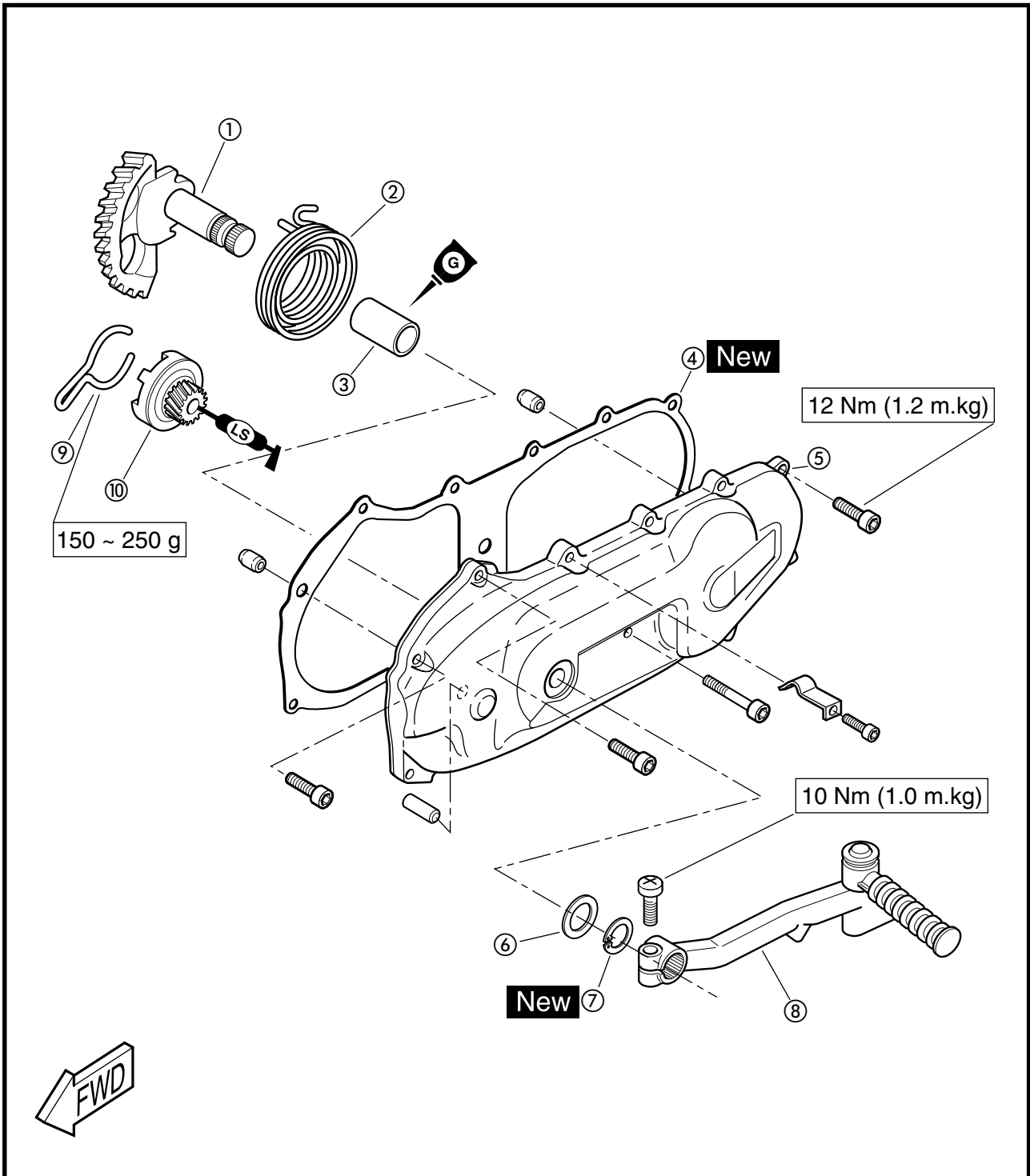

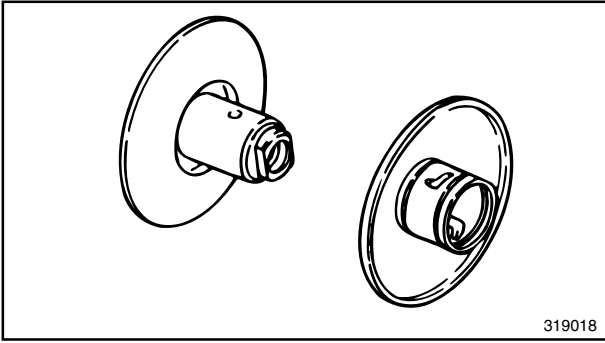

319018

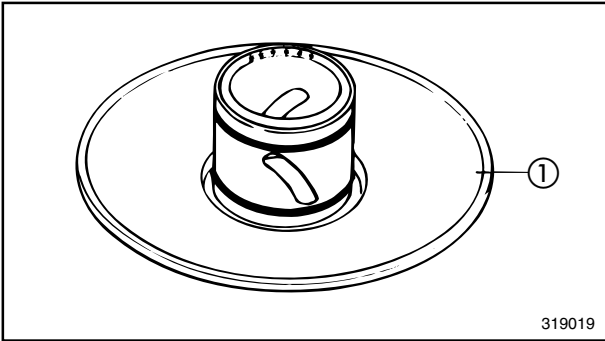

319019

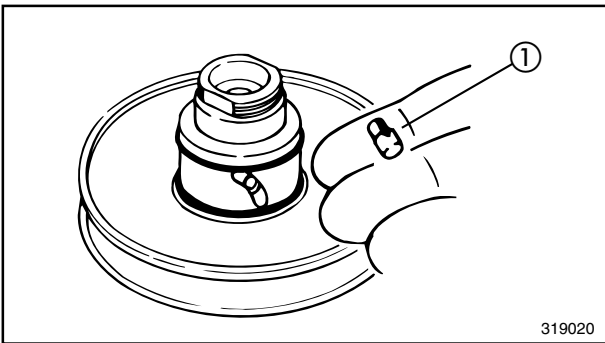

319020

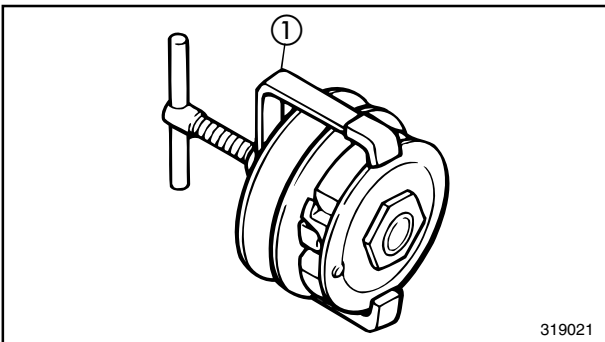

319021

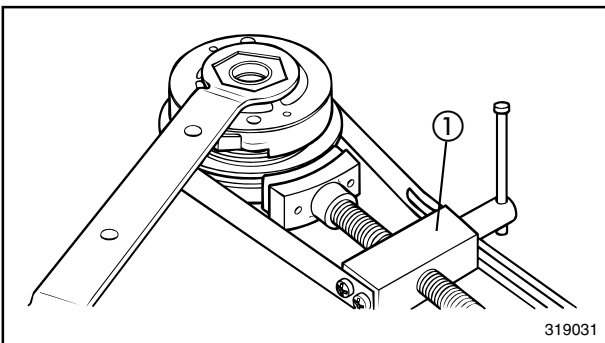

319031

SECONDARY SHEAVE

When assembling the secondary sheave, reverse the disassembly procedure. Note the following points.

1. Apply :
 - BEL-RAY Assembly Lube ®
(to the sliding parts of the sheave)

2. Install :
 - Sliding sheave ①

NOTE: _____
Wind adhesive tape around the end of the sheave to avoid turning over the oil seal lips when installing the sheave.

3. Install :
 - Pin ①

4. Apply :
 - BEL-RAY Assembly Lube ®
(to the torque cam grooves and O-rings)

5. Check :
 - Sliding sheave
 Unsmooth operation → Repair.

CAUTION: _____
Remove excessive grease.

6. Install :
 - Clutch securing nut
 Use the clutch spring holder ①

	Clutch spring holder : 90890-01337
--	---

7. Tighten :
 - Clutch securing nut
 Use sheave holder ① (41mm).

	Sheave holder : 90890-01701
--	--

	Clutch securing nut : 50 Nm (5.0 m.kg)
--	---

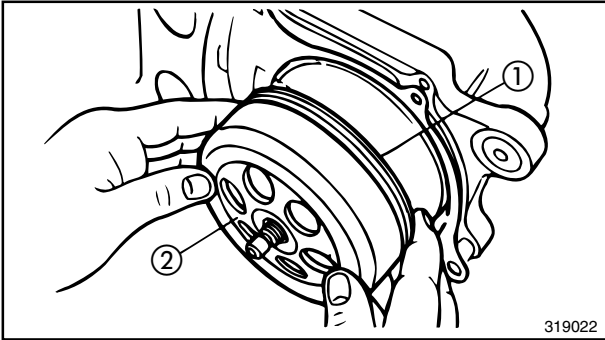

8. Install :
- Dowel pin
 - Gasket
 - Secondary sheave assembly ①
 - Clutch housing ②

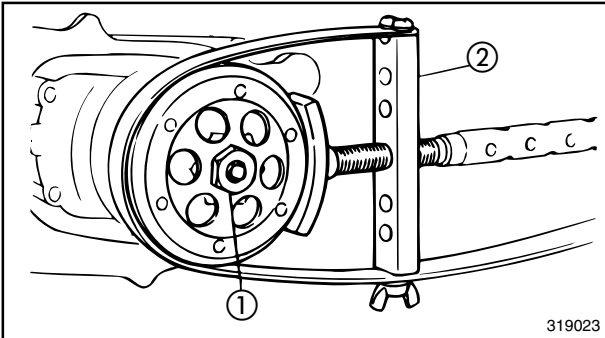

9. Tighten :
- Nut ① (secondary sheave)
- Use sheave holder ②

	Sheave holder : P/N. 90890-01701
--	--

	Nut (secondary sheave) : 30 Nm (3.0 m.kg)
--	---

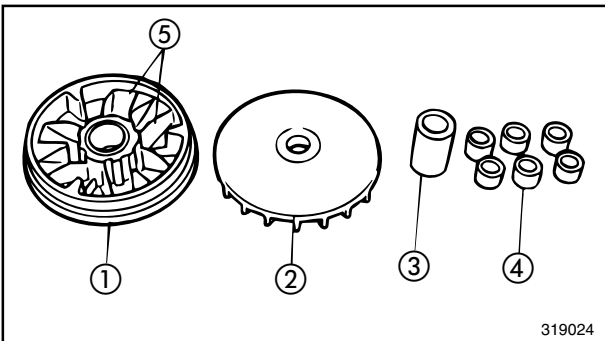

PRIMARY SHEAVE

1. Clean :
- Primary sliding sheave face ①
 - Primary fixed sheave face ②
 - Collar ③
 - Weight ④
 - Primary sliding sheave cam surface ⑤

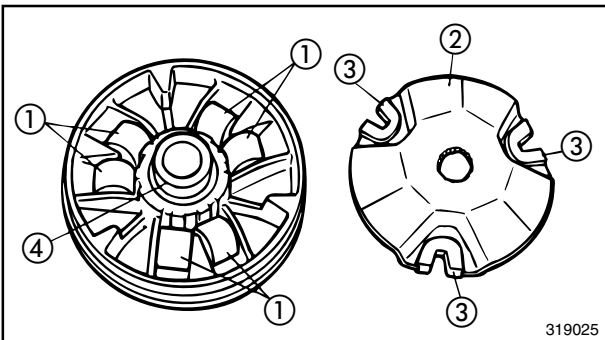

2. Install :
- Weight ①
 - Cam ②
 - Slider ③
 - Collar ④

3. Check :
- Cam operation
- Unsmooth operation → Repair.

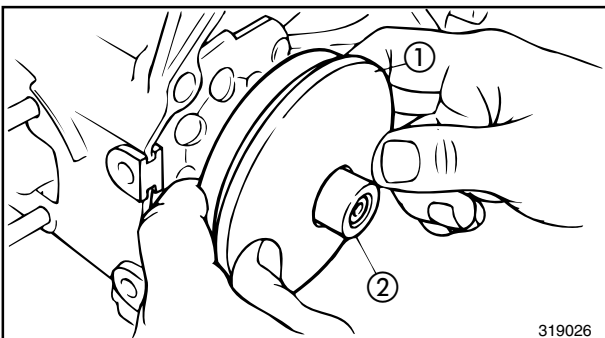

4. Install :
- Primary sheave assembly ①
 - Collar ②



5. Install :

- V-belt

Place the V-belt around the secondary sheave, and compress the secondary sheave spring hard so that the V-belt moves toward the clutch hub.

NOTE: _____

- The arrow on the V-belt must point to the front.
- Make sure the V-belt is not stained with oil or grease.

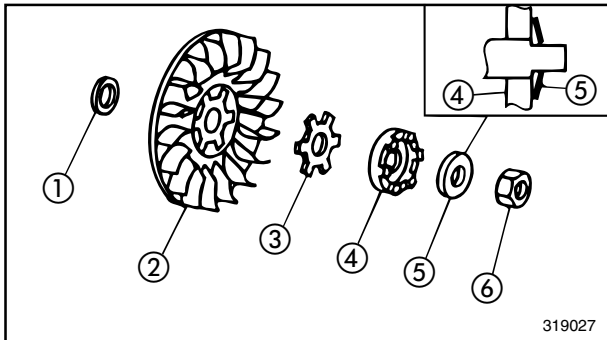

6. Install :

- Shim ①
- Primary fixed sheave ②
- Washer ③
- One-way clutch ④
- Washer ⑤
- Nut ⑥

7. Tighten :

Nut (primary sheave)

	Nut (primary sheave) : 33 Nm (3.3 m.kg)
--	--

NOTE: _____

When tightening the nut (primary sheave), hold the magneto rotor using the flywheel holding tool.

	Flywheel holding tool : 90890-01235
--	--

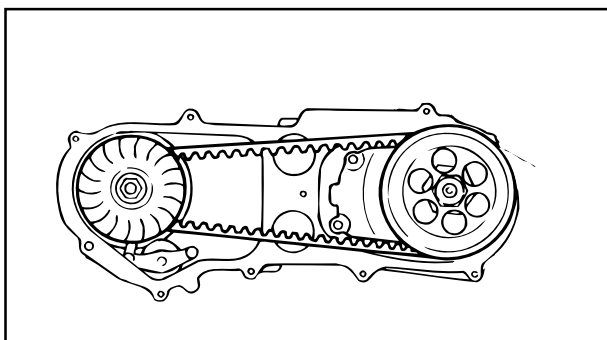

8. Adjust :

- V-belt

Tense the V-belt by turning the primary sheave several times.



9. Install :
- Fan



Screw (fan) :
7 Nm (0.7 m.kg)

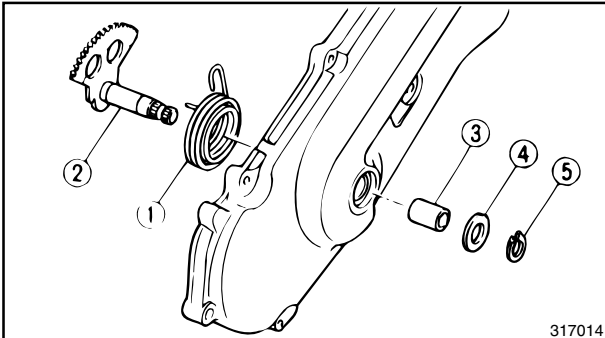

KICK STARTER

1. Install :
- Return spring ①
 - Kick shaft ②
 - Collar ③
 - Washer ④
 - Circlip ⑤

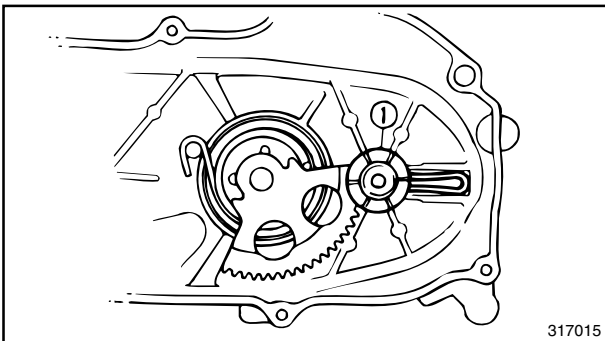

2. Hook :
- Return spring (to the kick gear and boss)

3. Install :
- Kick pinion gear ①

NOTE: _____
Install the clamp as shown.

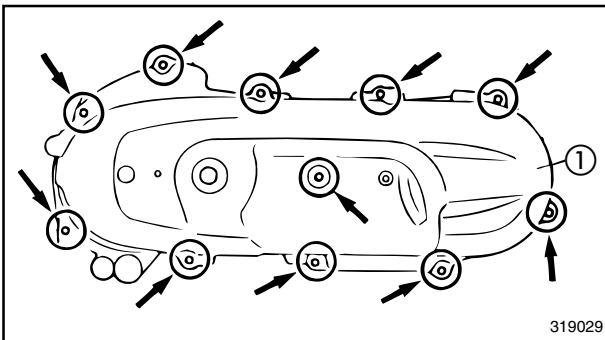

4. Install :
- Transmission case ①



Screw (Transmission case) :
12 Nm (1.2 m.kg)

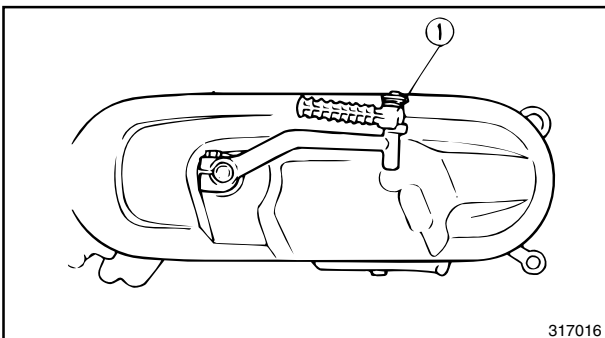

5. Install :
- Kick crank ①



Bolt (kick crank) :
10 Nm (1.0 m.kg)



PISTON PIN AND PISTON

1. Apply :

- Engine oil

(to crankshaft bearing, connecting rod big end bearing, small end bearing, piston pin, piston ring grooves and piston skirt .)

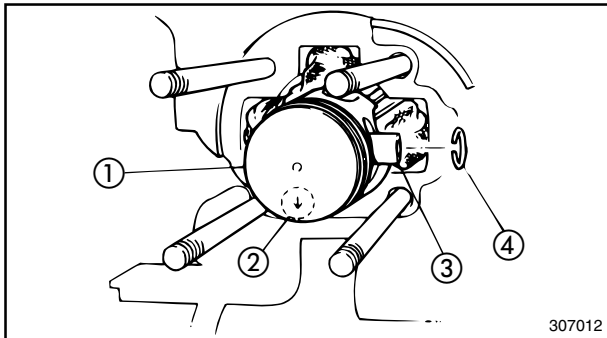

2. Install :

- Small end bearing
- Piston ①
- Piston pin ③
- Piston pin clip ④

NOTE:

- The arrow ② on the piston must point to the exhaust side.
- Before installing the piston pin clip, cover the crankcase with a clean towel or rag so you will not accidentally drop the pin clip and material into the crankcase.

CAUTION:

- The ends of the piston pin clip must not come together at the slot in the piston groove.
- Always use new piston pin clip.

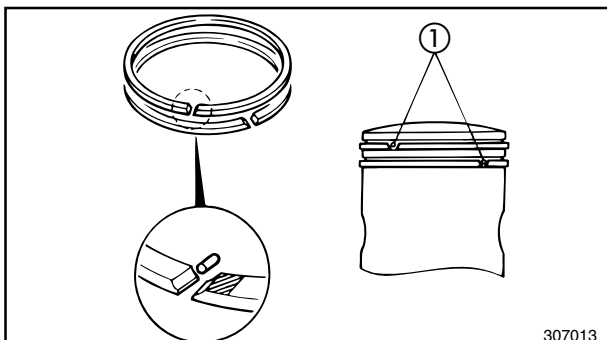

CYLINDER AND CYLINDER HEAD

1. Install :

- Cylinder gasket (new gasket)

2. Check :

- Piston rings

NOTE:

- Make sure the ring ends ① are properly fitted around the ring locating pins in the piston grooves.
- Be sure to check the manufacturer's marks or numbers stamped on the rings are on the top side of the rings.



3. Install :
- Cylinder

NOTE: _____
 Install the cylinder with one hand, while compressing the piston rings with the other hand.

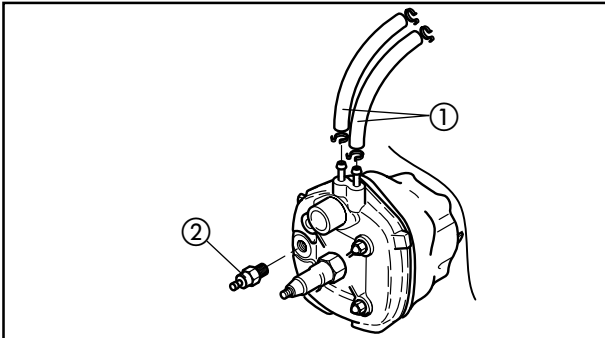

4. Install :
- Cylinder head gaskets (new gaskets)
5. Install :
- Cylinder head ①
 - Spark plug ②
 - Thermostat ③

NOTE: _____
 • Tighten the cylinder head holding nuts in stages, and crisscross sequence.
 • The arrow on the cylinder head must point to the front.



Nut (cylinder head) :
 14 Nm (1.4 m.kg)
Spark plug :
 20 Nm (2.0 m.kg)
Thermostat :
 16 Nm (1.6 m.kg)

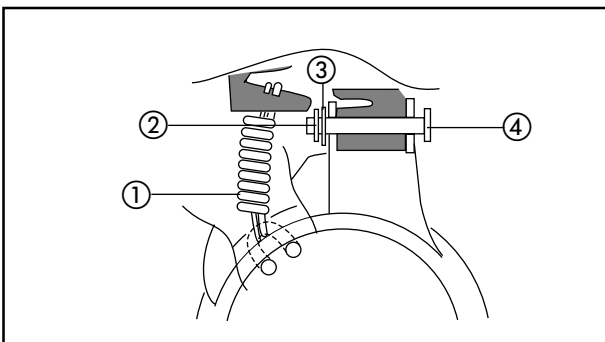

6. Install :
- Center stand
 - Axle ④
 - Plate washer ③
 - Clip ②
 - Spring ①

7. Install :
- Rear wheel
- Refer to chapter 8 "REAR WHEEL"



8. Install :
- Oil hose
 - Oil delivery hose

ENGINE REMOUNTING

Reverse the removal procedure.

Note the following points.

1. Install :
- Engine mounting bolt ②
 - Rear shock absorber bolt ① (lower)
- These bolts should be temporarily secured.

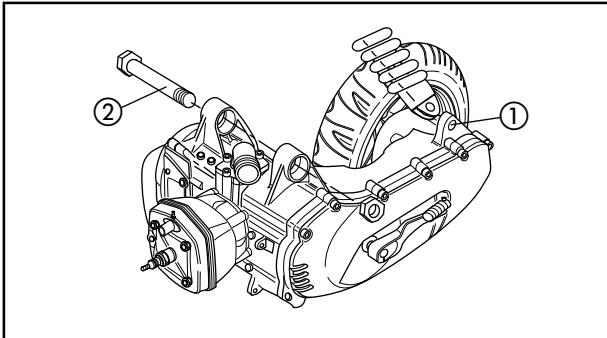

2. Tighten :
- Engine mounting bolt
 - Rear shock absorber bolt (lower)



Engine mounting bolt :
50 Nm (5.0 m.kg)
Rear shock absorber bolt (lower) :
16 Nm (1.6 m.kg)

3. Install :
- Carburetor top together with throttle valve ①
 - Fuel hose ②/Vacuum hose ③
 - Brake cable/plug cap

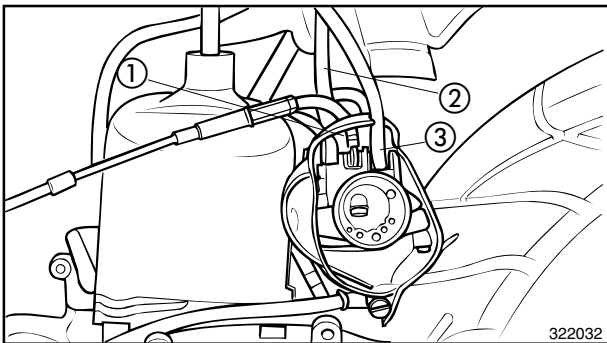

4. Connect:
- Water hoses

NOTE:

When installing the throttle valve into the carburetor, align the groove of the throttle valve with the projection of the carburetor.

5. Connect :
- Starter motor
 - CDI magneto lead
 - Earth
6. Install:
- Rear wheel collar assembly

NOTE:

Make sure the splines on the wheel hub fit onto the rear drive axle.

7. Tighten :
- Rear wheel axle nut ①

NOTE:

When tightening the rear wheel axle nut, apply the rear brake.



Rear wheel axle nut :
120 Nm (12 m.kg)

8. Install:

- Rear wheel

9. Tighten:

- Rear wheel fixing bolt



Rear wheel fixing bolt:
47 Nm (4.7 m.kg)

10. Install :

- Muffler assembly



Bolt (muffler) :
26 Nm (2.6 m.kg)
Bolt (exhaust pipe) :
9 Nm (0.9 m.kg)

11. Fill :

- Transmission oil

Refer to "CHAPTER 3 – TRANSMISSION OIL REPLACEMENT" section.

12. Fill:

- Radiator

Refer to "CHAPTER 5– "COOLING SYSTEM" section.

13. Adjust :

- Brake lever free play

Refer to "CHAPTER 3 – FRONT/REAR BRAKE LEVER FREE PLAY ADJUSTMENT" section.

- Engine idle speed

- Throttle cable free play

Refer to "THROTTLE CABLE FREE PLAY ADJUSTMENT" and "ENGINE IDLE SPEED ADJUSTMENT".

COOLING SYSTEM

1. Install :

- Coolant hose.

CAUTION :

Align the mark on the coolant hose with the mark on the water pump housing

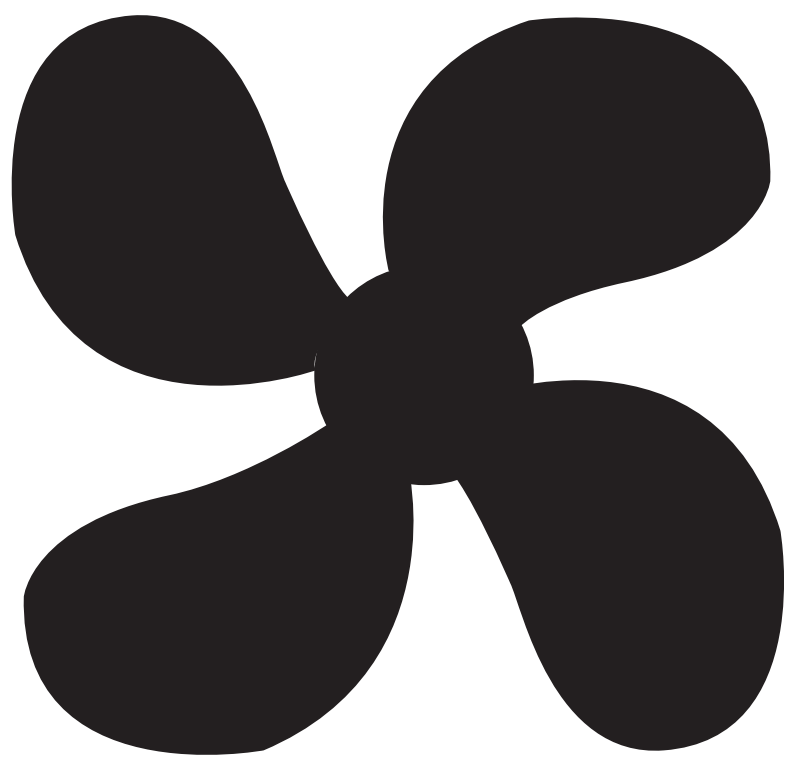

COOL

5

CHAPTER 5. COOLING SYSTEM

RADIATOR.....	5-1
REMOVAL.....	5-2
INSPECTION	5-2
INSTALLATION.....	5-2
WATER PUMP	5-3
REMOVAL.....	5-4
INSPECTION	5-4
INSTALLATION.....	5-4
THERMOSTATIC VALVE	5-5
REMOVAL.....	5-6
INSPECTION	5-6
INSTALLATION.....	5-6

COOLING SYSTEM

COOL



RADIATOR

- ① Coolant tank cap
- ② Coolant tank
- ③ Radiator
- ④ Hose
- ⑤ Water pump
- ⑥ O-Ring
- ⑦ Impeller O-Ring
- ⑧ Cylinder Head
- ⑨ Cylinder
- ⑩ Thermostatic valve
- ⑪ Thermo switch

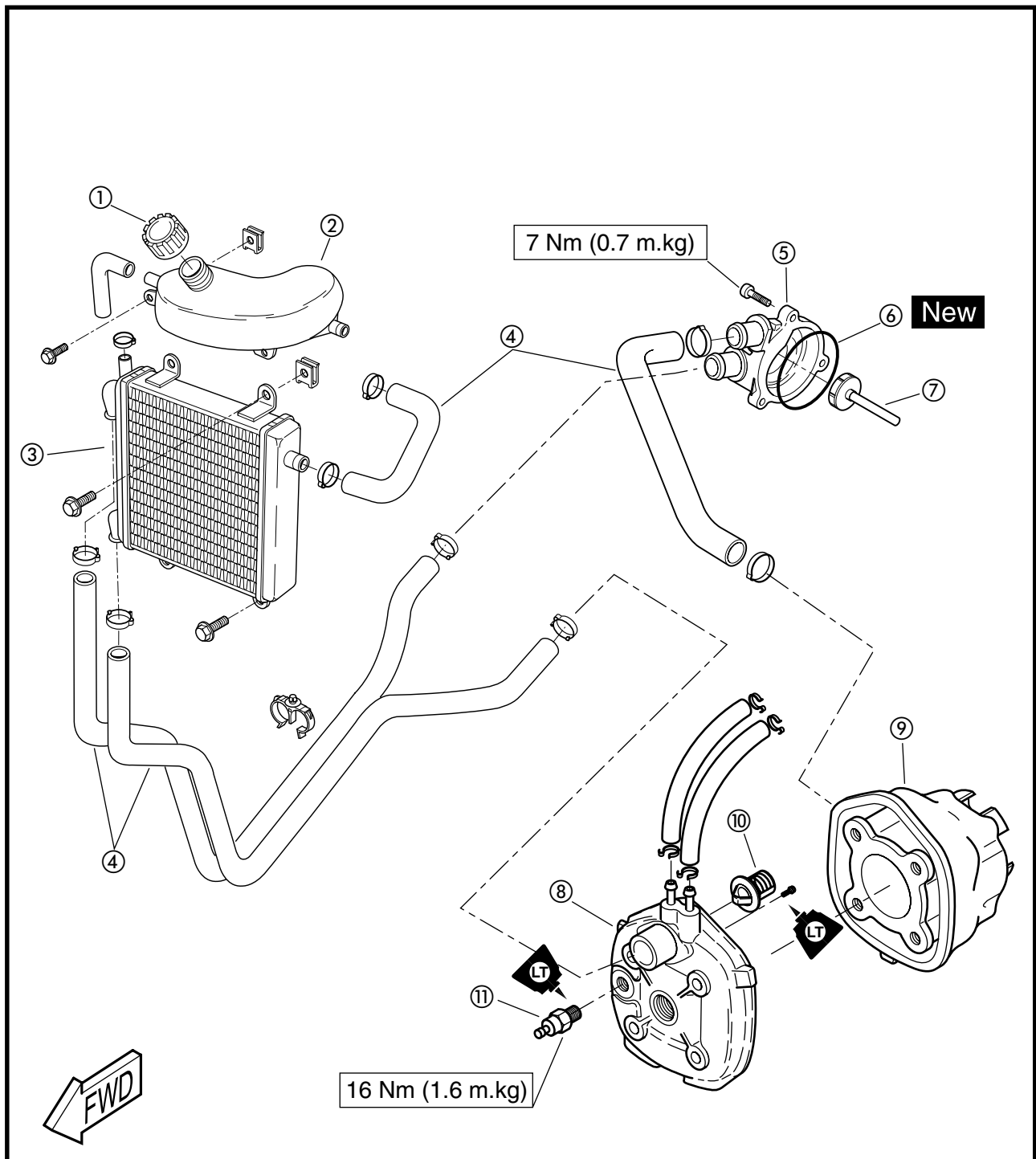

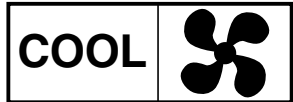

COOLING SYSTEM RADIATOR REMOVAL

1. Remove:

- Air filter
- Carburetor assembly

Refer to chepter 6 "CABURETOR"

2. Drain:

- Radiator

Refer to chapter 3 "COOLANT REPLACEMENT"

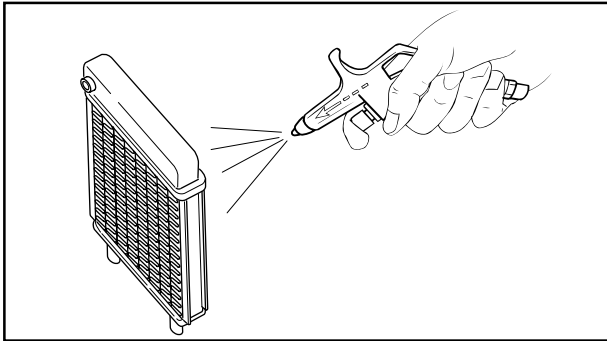

3. Remove:

- Hose
- Radiator assembly.

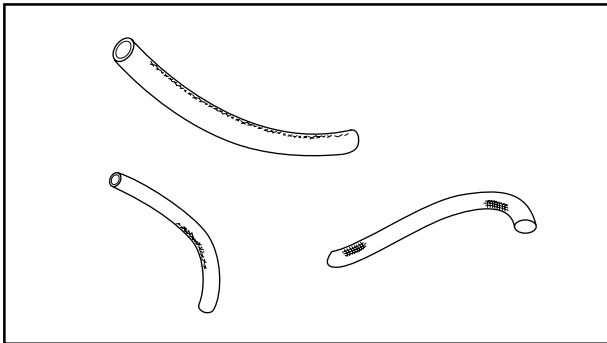

INSPECTION

1. Inspect:

- Radiator core

Obstruction → Blow out with compressed air through rear of the radiator.

Flattened fin → Repair/Remplace.

2. Inspect:

- Radiator hoses

Cracks/Damage → Replace

3. Inspect:

- Coolant tank

Cracks/Damage → Replace

INSTALLATION

Reverse the "REMOVAL" procedure.

Refer to the chapter 2 " CABLE ROUTING"

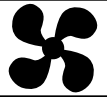

WATER PUMP

- ① Water pump housing
- ② O-Ring
- ③ Impeller
- ④ Seal
- ⑤ Cover
- ⑥ Bearing
- ⑦ Spacer
- ⑧ Bearing
- ⑨ Rotor
- ⑩ Circlips
- ⑪ Rubber
- ⑫ Driving plug
- ⑬ Washer

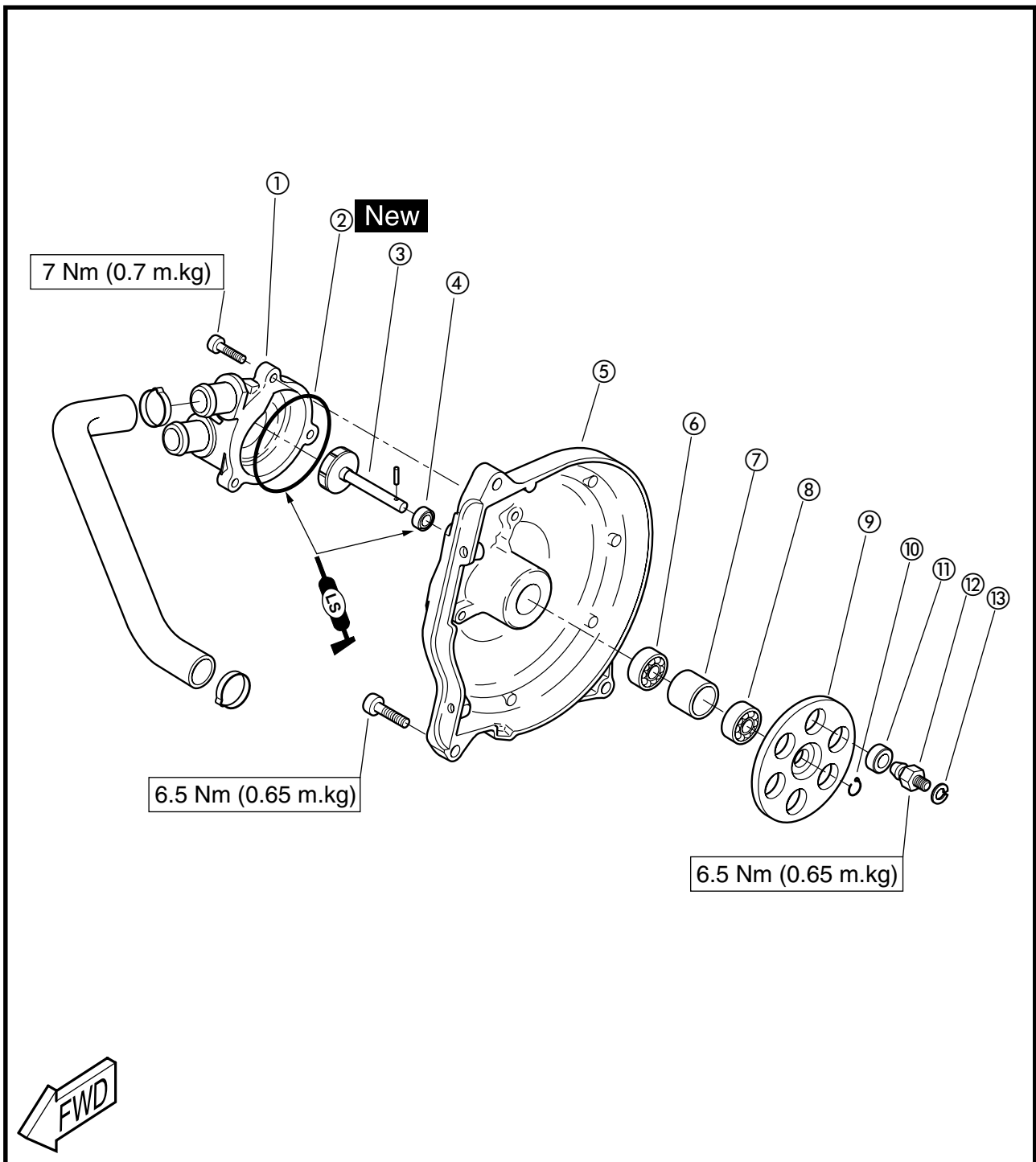

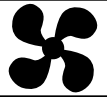

WATER PUMP REMOVAL

1. Remove:

- Side cover

Refer to chapter 3 "COVER"

2. Drain:

- Radiator
- Hoses

Refer to chapter 3 "COOLANT REPLACEMENT"

3. Remove:

- Water pump fixing bolts
- Water pump
- Hoses

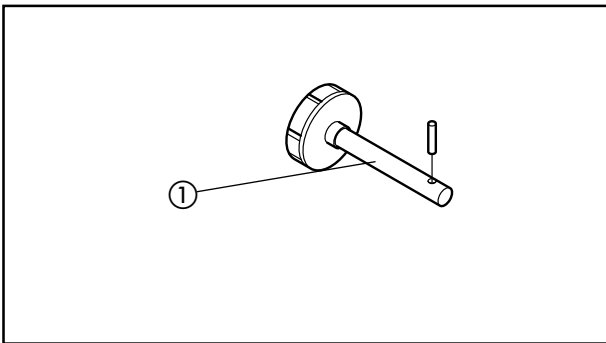

INSPECTION

1. Inspect:

- Impeller ①

Used/Damaged → Replace

Scale deposit → Clean

2. Inspect:

- Rotor

Used/Damaged → Replace

INSTALLATION

Reverse the "REMOVAL" procedure.

Note the following points.

NOTE: _____

- It is not necessary to remove and inspect the water pump if the coolant is not unusually low or if it has no engine oil mixed in it.
- Always replace the entire water pump as a set.

1. Apply:

- Lithium soap base grease (to the seal)

2. Install:

- Water pump assembly
- Side cover

CAUTION : _____

Align the mark on the hoses with the mark on the water pump housing.



THERMOSTATIC VALVE

- ① Thermostatic switch
- ② Cylinder head
- ③ Thermostatic valve
- ④ Cylinder

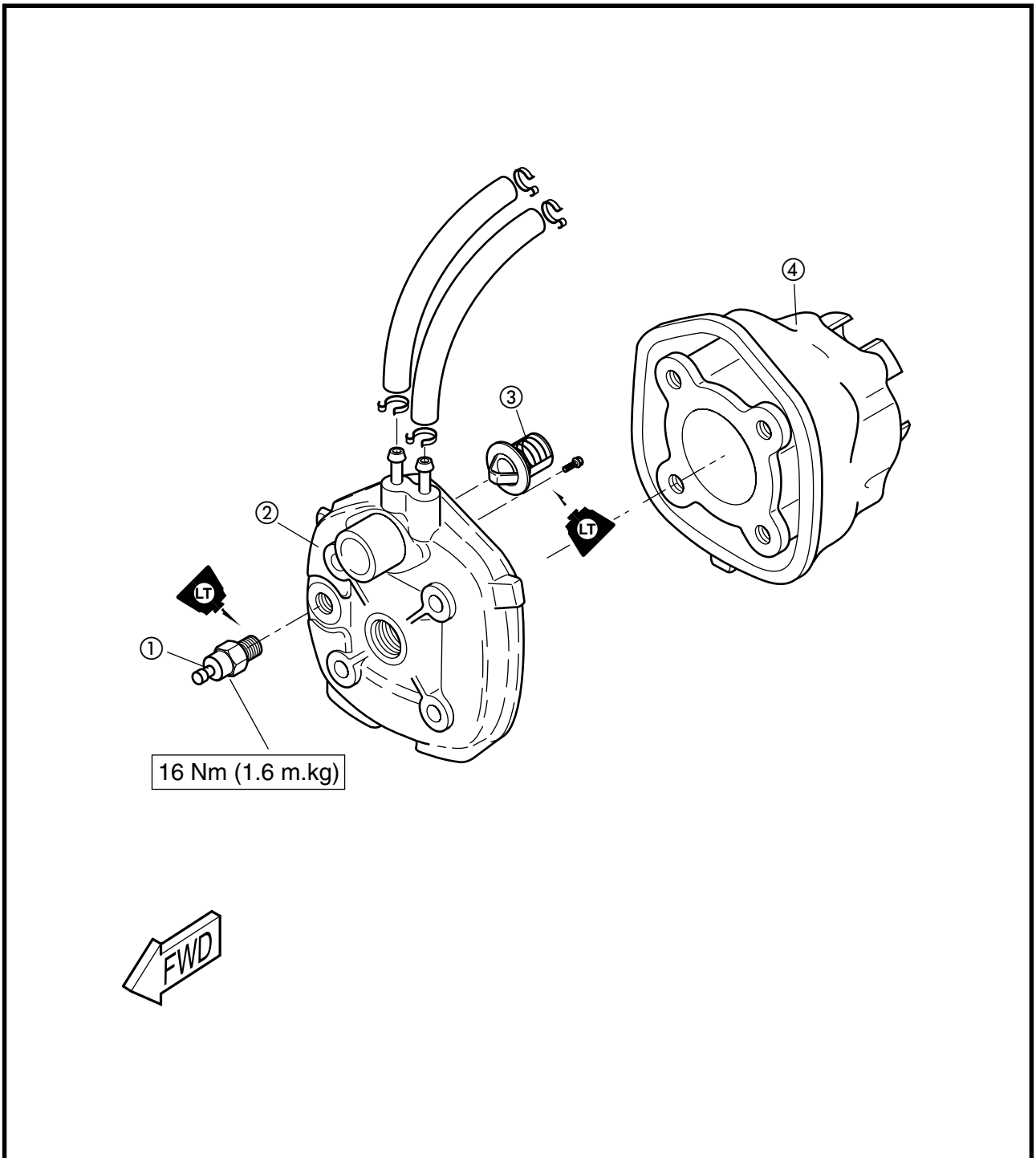

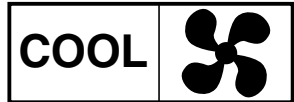

THERMOSTATIC VALVE REMOVAL

1. Drain:

- Coolant

Refer to the chapter 3 "COOLANT REPLACEMENT"

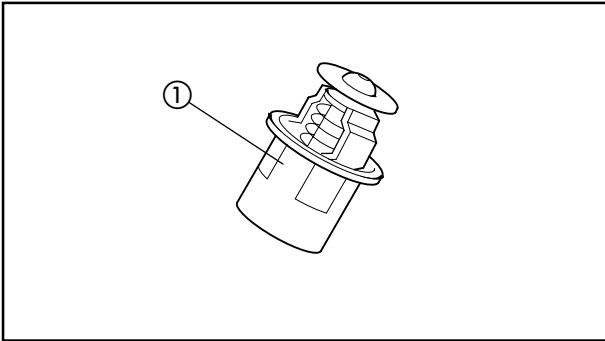

2. Remove:

- Cylinder head
- Thermostatic valve ①

INSPECTION

1. Inspect:

- Thermostatic valve

Valve does not open → Replace

Inspection steps:

- Suspend thermostatic valve in a vessel.
- Place reliable thermometer in a water.
- Observe thermometer, while stirring water continually.

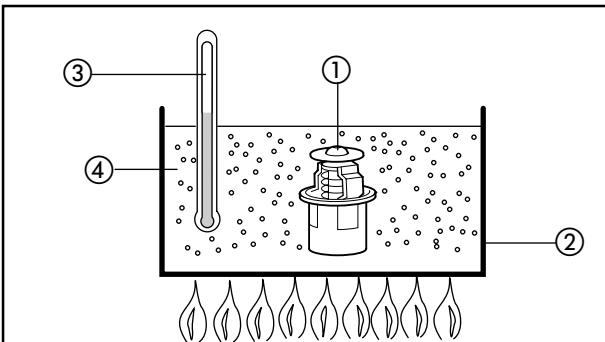

- ① Thermostatic valve
- ② Vessel
- ③ Thermometer
- ④ Water

INSTALLATION

Reverse the "REMOVAL" procedure.

	Thermostat valve screws: 5Nm (0.5 m.kg)
--	--

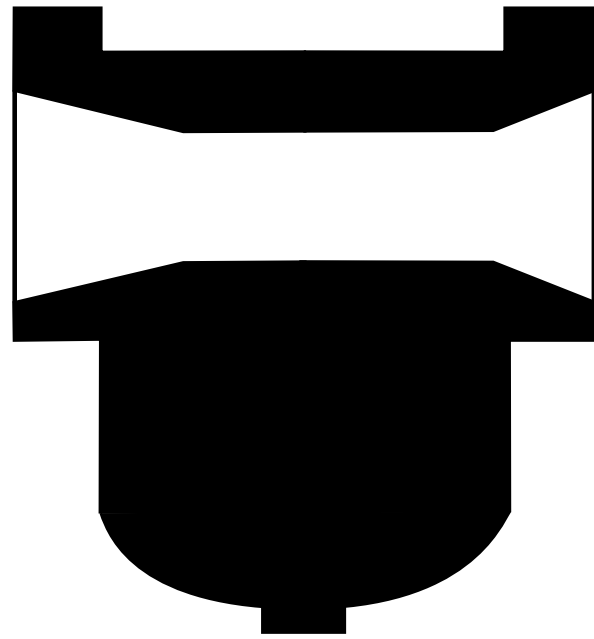

CARB

6

CHAPTER 6. CARBURETION

CARBURETOR	6-1
DELL'ORTO CARBURETOR	6-1
REMOVAL	6-2
DISASSEMBLY	6-2
INSPECTION	6-3
ASSEMBLY	6-5
INSTALLATION	6-6
FUEL COCK	6-7
INSPECTION	6-7
REED VALVE	6-7
REMOVAL	6-7
INSPECTION	6-8
INSTALLATION	6-9



DELL'ORTO CARBURETOR

- ① Carburetor top
- ② Gasket
- ③ Throttle valve spring
- ④ Needle set
- ⑤ Throttle valve
- ⑥ Starter plunger spring
- ⑦ Starter plunger
- ⑧ Air screw
- ⑨ Throttle stop screw
- ⑩ Pilot jet
- ⑪ Needle jet
- ⑫ Needle valve
- ⑬ Main jet
- ⑭ Float pin
- ⑮ Float
- ⑯ Float chamber gasket
- ⑰ Float chamber
- ⑱ Drain screw

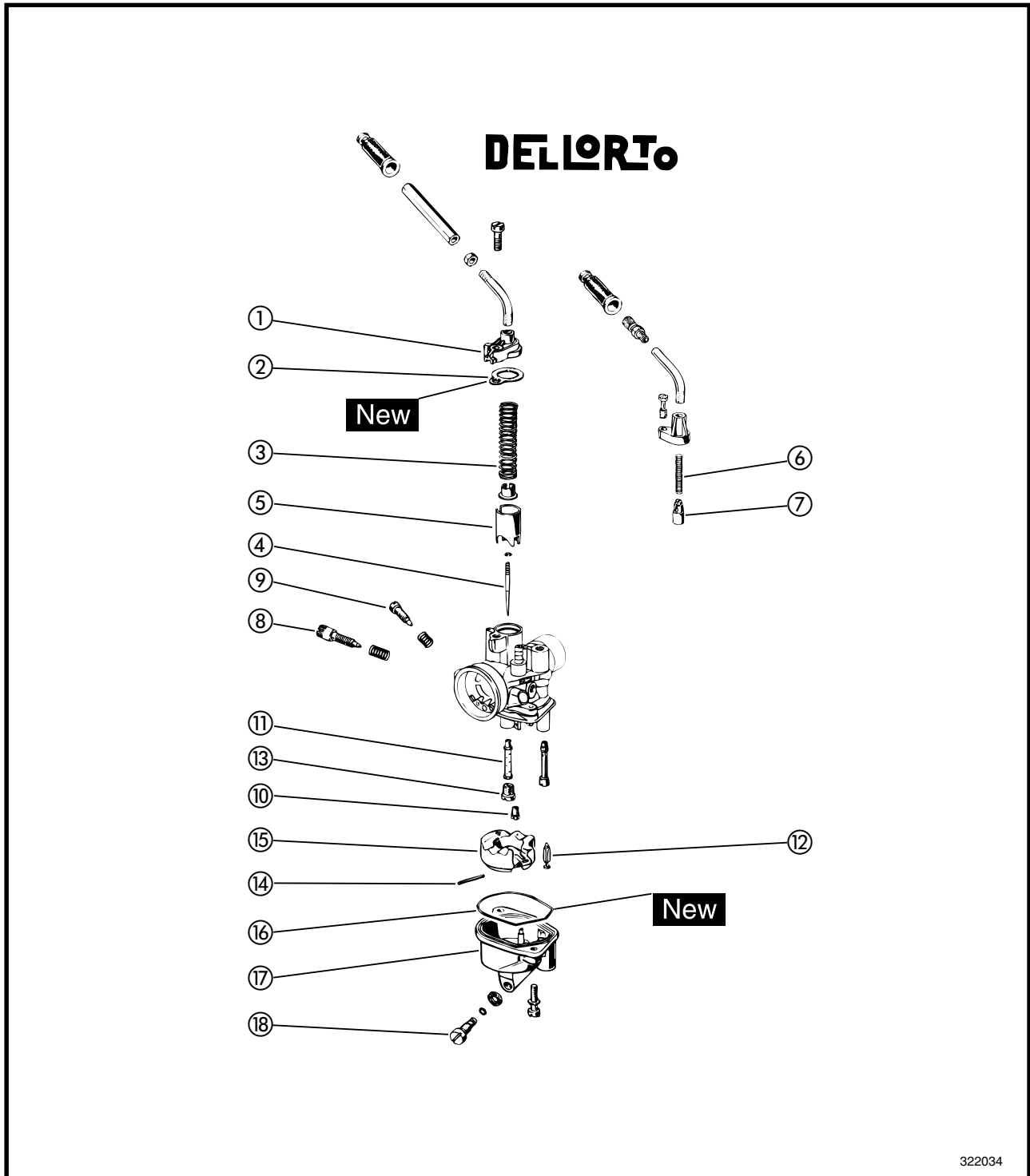

322034



REMOVAL

1. Remove :

- Side covers and footrest board

Refer to the section "SIDE COVERS AND FOOTREST BOARD" in Chapter 3.

- Air filter case assembly

2. Drain:

- Coolant

Refer to chapter 3 "COOLANT REPLACEMENT"

3. Disconnect :

- Fuel hose
- Oil hose
- Coolant hoses

4. Remove :

- Carburetor top
- Throttle valve
- Starter plunger top
- Starter plunger
- Carburetor

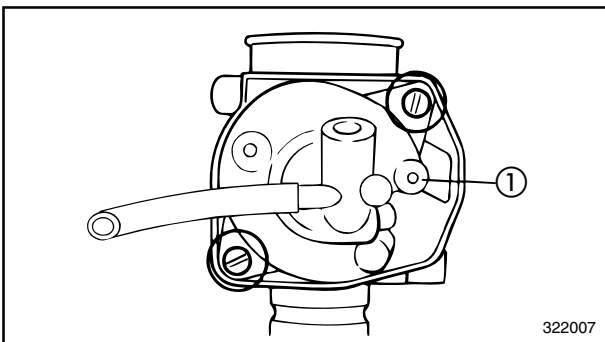

DISASSEMBLY

1. Remove :

- Float chamber ①

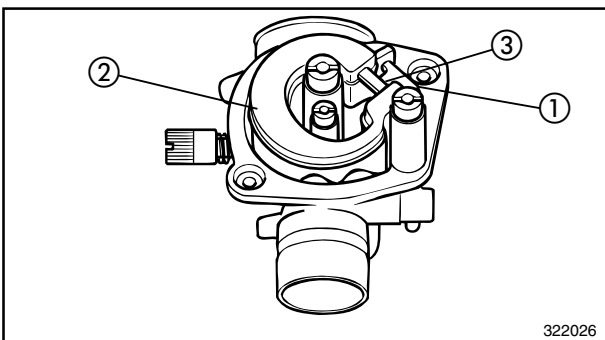

2. Remove :

- Float pin ①
- Float ②
- Needle valve ③

CARBURETOR

CARB

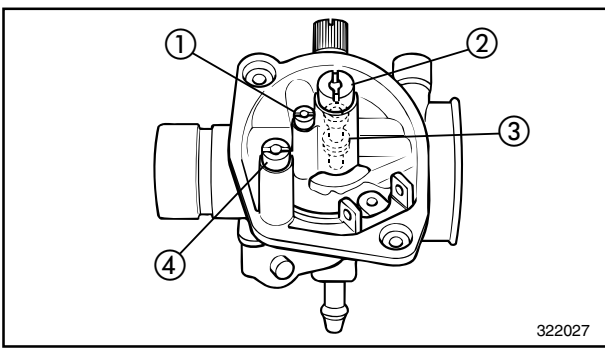

3. Remove :
- Pilot jet ①
 - Main jet ②
 - Main nozzle ③
 - Starter jet ④

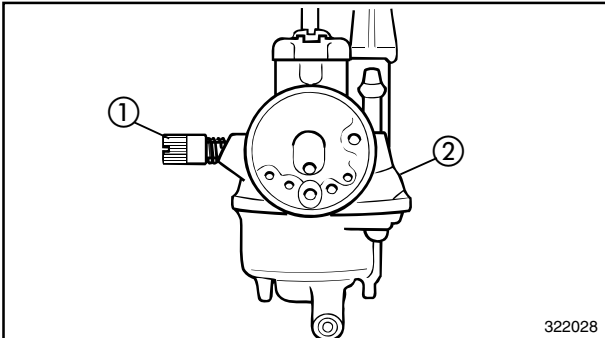

4. Remove :
- Throttle stop screw ①
 - Spring (throttle stop screw)
 - Air screw ②
 - Spring (air screw)

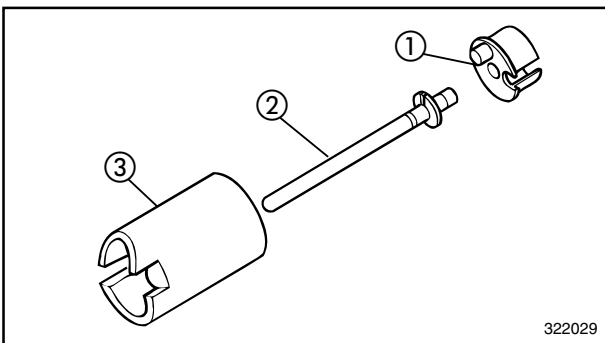

5. Remove :
- Needle clip ①
 - Jet needle ②
 - Throttle valve ③

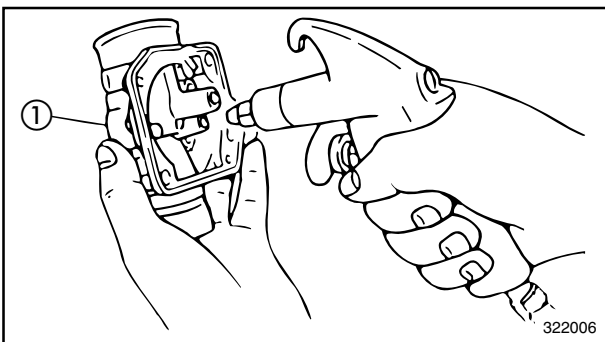

INSPECTION

1. Check :
- Carburetor body ①
Dirt → Clean.

NOTE: _____
Use a petroleum based solvent for cleaning.
Blow out all passages and jets with compressed air.

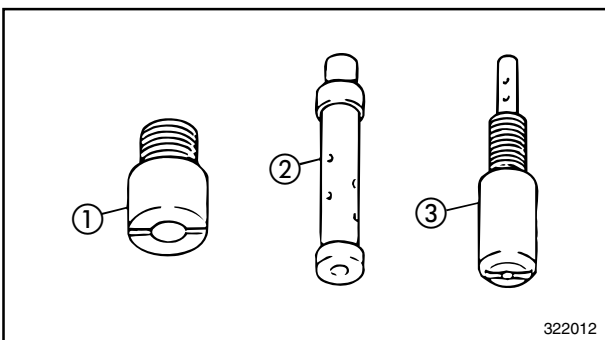

2. Inspect :
- Main jet ①
 - Main nozzle ②
 - Pilot jet ③
 - Starter jet
- Contamination → Clean.

CARBURETOR

CARB

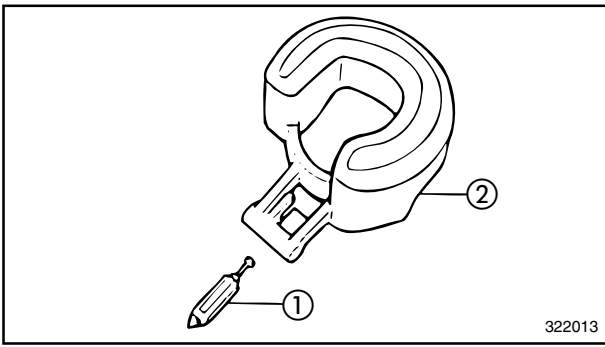

3. Check :
- Needle valve ①
Wear/Contamination → Replace.
 - Float ②
Damage → Replace.
 - Gasket
Damage → Replace.

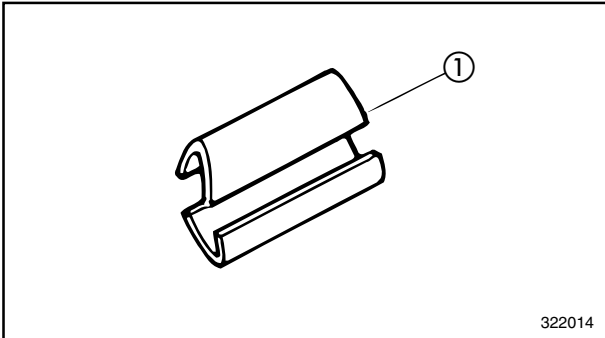

4. Check :
- Throttle valve ①
Wear/Damage → Replace.

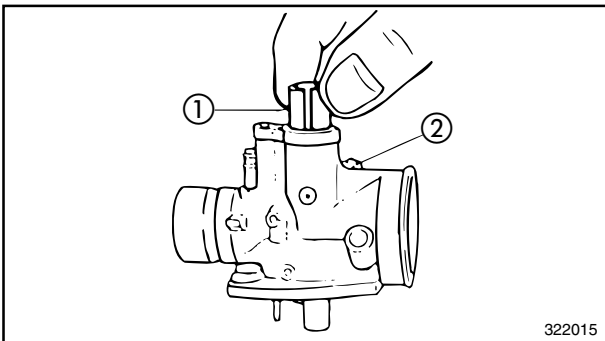

5. Check :
- Throttle valve free movement
Unsmooth/stickiness → Replace.
- Insert the throttle valve ① into the carburetor body ② and check for smooth movement.

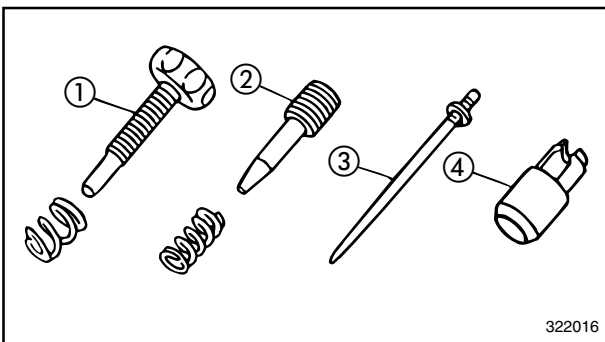

6. Check :
- Throttle stop screw ①
 - Air screw ②
 - Needle ③
 - Starter plunger ④
Wear/Damage → Replace.

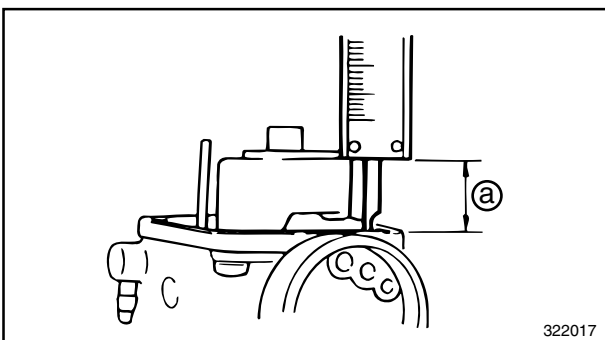

7. Measure :
- Float height @
Out of specification → Inspect needle valve, float, and valve seat.



Float height @ :
15.0 ~ 17.0 mm (0.59 ~ 0.67 in)



Float height measurement steps :

- Install the needle valve, float and float pin into the carburetor body.
- Hold the carburetor upside down.
- Measure the height distance between the mating surface of the float chamber (gasket removed) and the top of the float, using a gauge.

NOTE: _____

The float arm should be resting on the needle valve. It should not compress the needle valve.

- If the float height is not within specification, inspect the needle valve, float and valve seat.
- If one of these parts is worn, replace the whole set.
- If both parts are in good condition, replace the float.
- Check the float height again.

NOTE: _____

The float height is factory-adjusted. Never try to adjust it yourself.

ASSEMBLY

Reverse the "DISASSEMBLY" procedures. Note the following points.

CAUTION: _____

- **Before reassembling the carburetor wash all its components in clean gasoline.**
- **Always use new gaskets.**

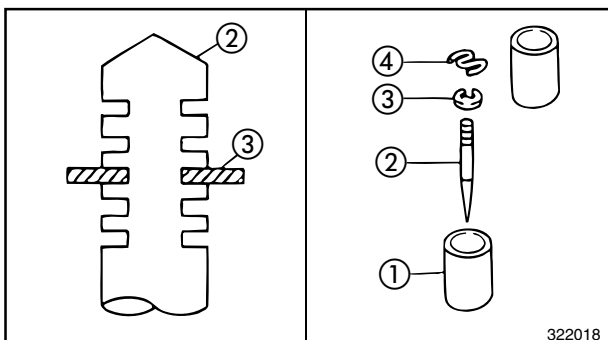

1. Install :
- Needle ②
 - Clip ③
 - Throttle valve ①
 - Spring seat ④
 - Spring

 **Jet needle clip position :
See specifications on Chapter 2**

CARBURETOR

CARB

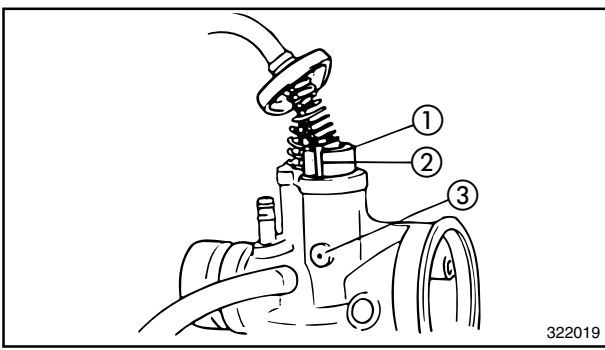

2. Install :

- Throttle valve ①
- Starter plunger

NOTE: _____

Align the groove ② of the throttle valve with the projection ③ of the carburetor body.

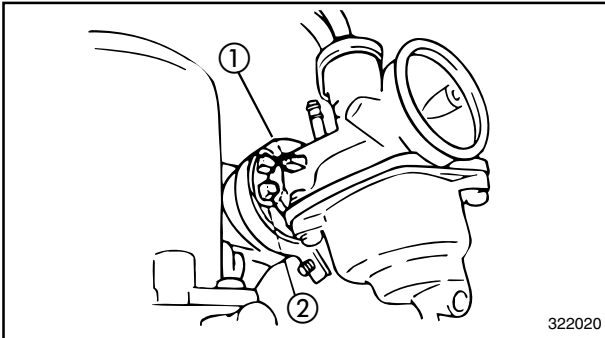

3. Install :

- Carburetor

NOTE: _____

Align projection ① with projection ②.

INSTALLATION

To install the carburetor reverse the "REMOVAL" procedures. Note the following points.

1. Install :

- Carburetor cover

2. Connect:

- Coolant hose.

3. Adjust :

- Throttle cable free play

Refer to the section "THROTTLE CABLE FREE PLAY ADJUSTMENT" in Chapter 3.

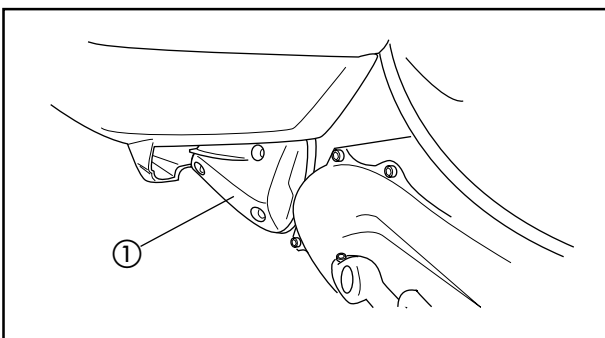

4. Install :

- Air filter case ①

5. Fill:

- Coolant.

Refer to the chapter 3 "COOLANT REPLACEMENT"

FUEL COCK/ FUEL FILTER CLEANING/ REED VALVE



FUEL COCK

INSPECTION

1. Stop the engine.

2. Remove :

- Side covers

Refer to the section "SIDE COVERS AND FOOTREST BOARD" in Chapter 3.

3. Check :

- Fuel cock

Fuel cock inspection steps :

- Disconnect the fuel hose.
- Place a receptacle under the fuel hose end.
- If fuel stops flowing within a few seconds, the fuel cock is in good condition. If not clean or replace the fuel cock.
- Disconnect the vacuum hose and breathe in through the hose to create a vacuum in the fuel cock.

If fuel flows out of the fuel hose when vacuum is applied and stops flowing when vacuum stops, the fuel cock is in good condition.

If not, clean or replace the vacuum hose, the fuel hose and the fuel cock.

FUEL FILTER CLEANING

The fuel filter is fitted inside the fuel tank. It is accessible when the fuel hose (between the fuel tank and the fuel cock) is disconnected.

Refer to the chapter 2 "CABLE ROUTING" for proper installation.

REED VALVE

REMOVAL

1. Remove :

- Side covers

Refer to the section "SIDE COVERS AND FOOTREST BOARD" in Chapter 3.

2. Remove :

- Carburetor

Refer to section "CARBURETOR REMOVAL".

REED VALVE

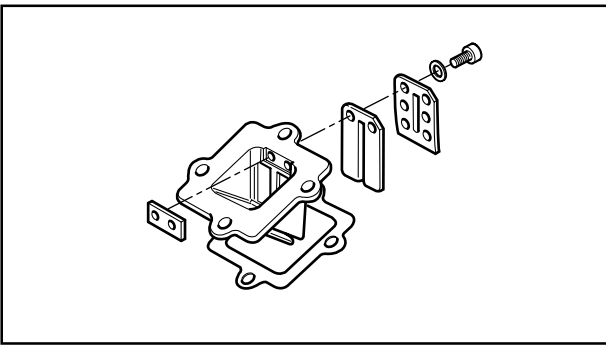

3. Remove :
- Carburetor joint
 - Reed valve assembly

INSPECTION

1. Check :
- Carburetor joint
Damage/Cracks → Replace.
 - Reed valve
Wear/Cracks/Damage → Replace.

Reed valve inspection steps :

- Visually inspect the reed valve.

NOTE: _____

A reed valve in good condition should be completely or at least nearly flush with the valve seat.

- If in doubt, apply suction to the carburetor side of the assembly.
- Leakage should be minimal to moderate.

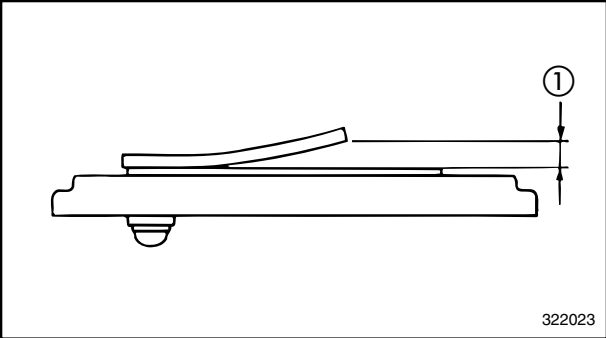

2. Measure :
- Valve stopper height ①
Out of specification → Replace valve stopper.

	Valve stopper height : 6,0 ~ 6,4 mm (0.23 ~ 0.25 in)
---	--

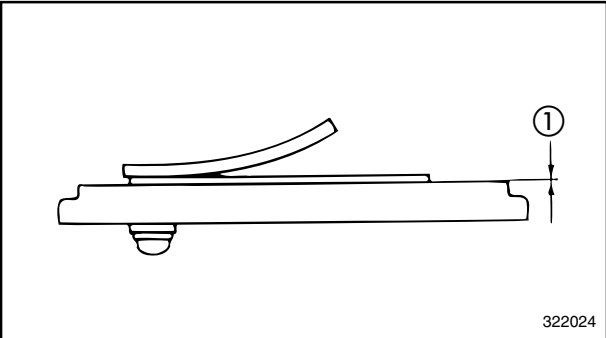

3. Measure :
- Reed valve clearance ①
Out of specification → Replace reed valve.

	Reed valve clearance : Less than 0.2 mm (0.008 in)
---	--

REED VALVE

CARB



INSTALLATION

To install the reed valve reverse the “REMOVAL” procedure. Note the following points.

1. Install :

- Gasket (new)

2. Tighten :

- Reed valve assembly bolts



Reed valve assembly bolts :
9 Nm (0.9 m.kg)

NOTE:

Tighten the screws crosswise in several steps to prevent warpage of the reed valve assembly and the carburetor joint.

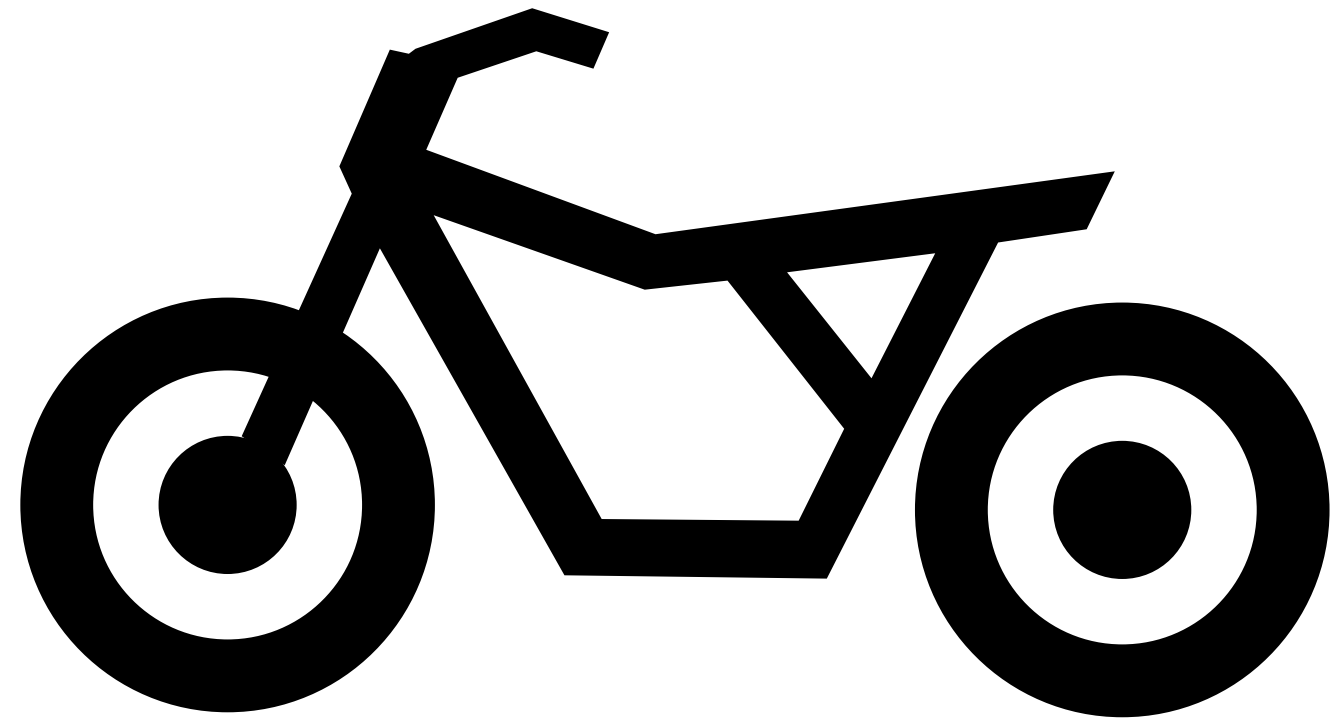

CHAS

7

**CHAPTER 7.
CHASSIS**

FRONT WHEEL 7-1
 REMOVAL 7-2
 INSPECTION 7-2
 INSTALLATION 7-3

FRONT BRAKE 7-4
 BRAKE PAD REPLACEMENT 7-6
 CALIPER DISASSEMBLY 7-7
 MASTER CYLINDER DISASSEMBLY 7-8
 INSPECTION AND REPAIR 7-9
 CALIPER ASSEMBLY 7-10
 MASTER CYLINDER ASSEMBLY 7-11

REAR WHEEL 7-13
 REAR MASTER CYLINDER 7-14
 REMOVAL 7-15
 INSPECTION 7-15
 ASSEMBLY 7-16
 INSTALLATION 7-16

FRONT FORK 7-17
 REMOVAL 7-18
 DISASSEMBLY 7-19
 INSPECTION 7-20
 ASSEMBLY 7-20
 INSTALLATION 7-21

STEERING HEAD AND HANDLEBAR 7-22
 REMOVAL 7-23
 INSPECTION 7-24
 ASSEMBLY AND INSTALLATION 7-25

CHASSIS

FRONT WHEEL

- ① Axle
- ② Speedometer gear
- ③ Bearing
- ④ Collar
- ⑤ Front rim
- ⑥ Tire
- ⑦ Valve
- ⑧ Collar
- ⑨ Spacer
- ⑩ Nut

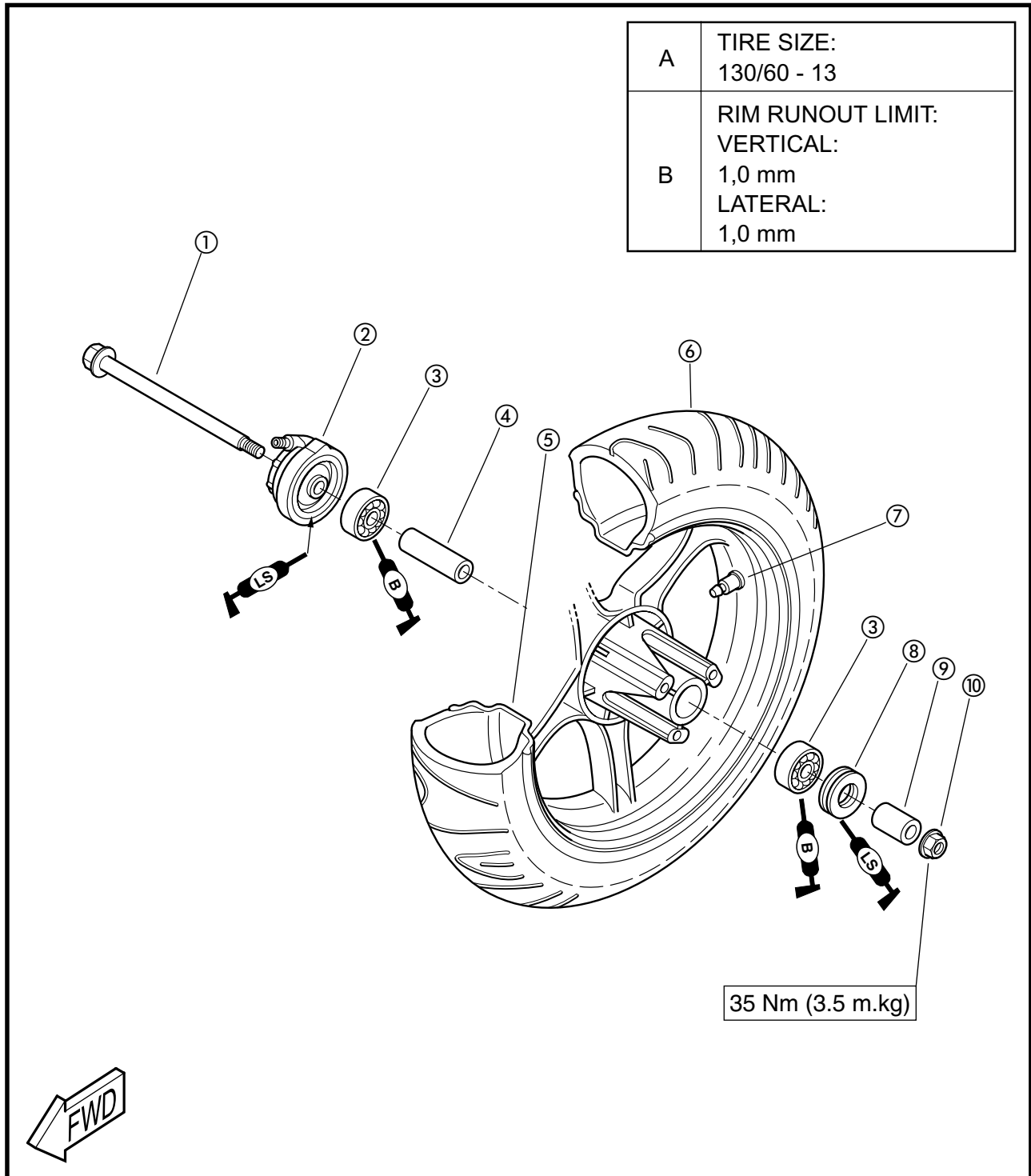

FRONT WHEEL

CHAS

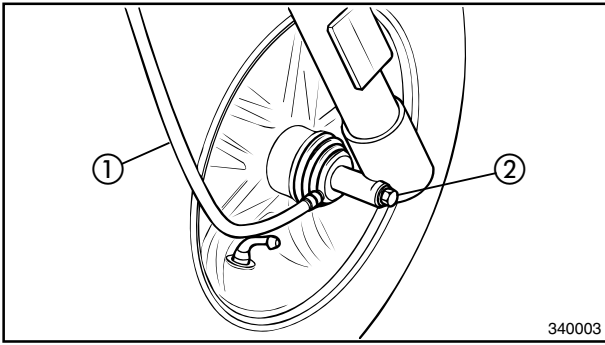

REMOVAL

1. Remove :
 - Front caliper fixing bolts
 - Front caliper
 - Speedometer cable ①
 - Axle ②
 - Front wheel

NOTE:

Never depress the brake lever when the wheel is off the scooter. Otherwise the brake pads will be forced out.

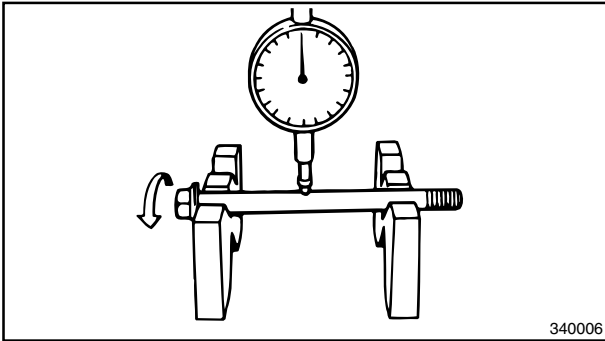

INSPECTION

1. Inspect :
 - Front axle runout
Out of specification → Replace.



Axle runout limit:
0.25 mm (0.01 in)

⚠ WARNING

Do not attempt to straighten a bent axle.

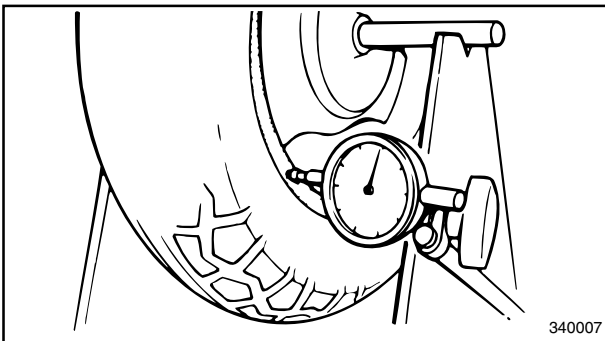

2. Measure :
 - Wheel runout
Out of specification → Replace.



Rim runout limit:
Radial: 1.0 mm (0.04 in)
Lateral: 1.0 mm (0.01 in)

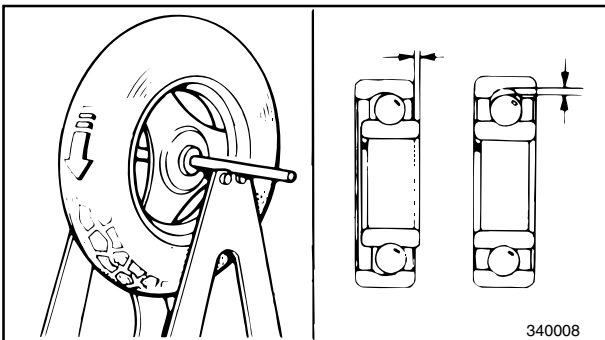

3. Inspect :
 - Tire
Wear/Cracks/Warpage → Replace.

4. Inspect :
 - Wheel bearings
Bearings allow play in the wheel hub or wheel turns roughly → Replace.

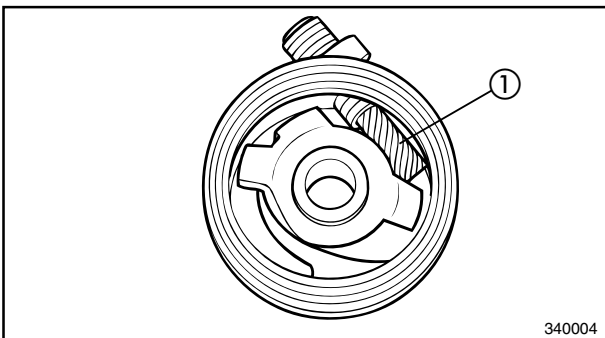

5. Check :
 - Speedometer gear ①
Wear/Damage → Replace.

INSTALLATION

Reverse the "Removal" procedure.
Note the following points.

1. Lubricate :
- Front wheel axle
 - Bearings
 - Oil seal (lips)
 - Drive/driven gear (speedometer)

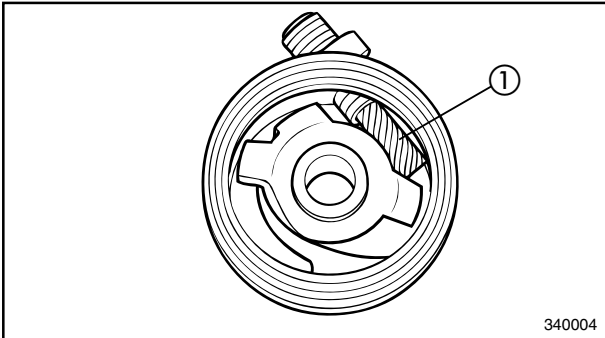

 **Recommended lubricant :**
Lithium soap base grease

2. Install :
- Speedometer gear unit ①

NOTE: _____
Be sure that the two projections at the gear unit mesh with the two slots on the wheel hub.

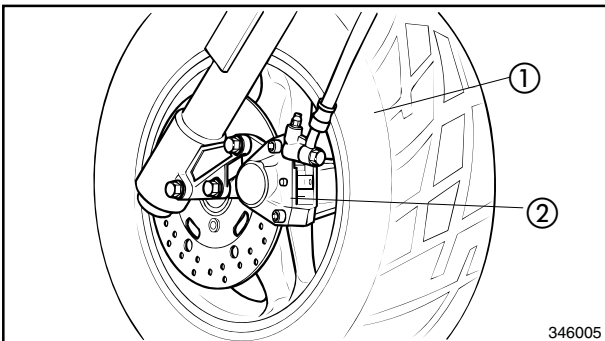

3. Install :
- Front wheel ①
 - Front caliper ②

NOTE: _____
Be sure that the slot (torque stopper) of the gear unit housing is positioned correctly.

4. Tighten :
- Front wheel axle
 - Front caliper mounting bolts
- Apply Loctite

 **LOCTITE®**

 **Front wheel axle :**
35 Nm (3.5 m.kg)
Front caliper mounting bolts :
23 Nm (2.3 m.kg)

⚠ WARNING _____
Make sure that the brake hoses are routed properly.

FRONT BRAKE

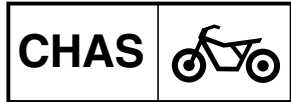

FRONT BRAKE

- ① Disk
- ② Bolt
- ③ Caliper
- ④ Piston
- ⑤ Piston seals
- ⑥ Air bleed screw
- ⑦ Pad spring
- ⑧ Pad retainer
- ⑨ Brake pads
- ⑩ O-Ring
- ⑪ Bolt
- ⑫ Mounting bolt

NOTE: _____
 Be sure to install the pads correctly.

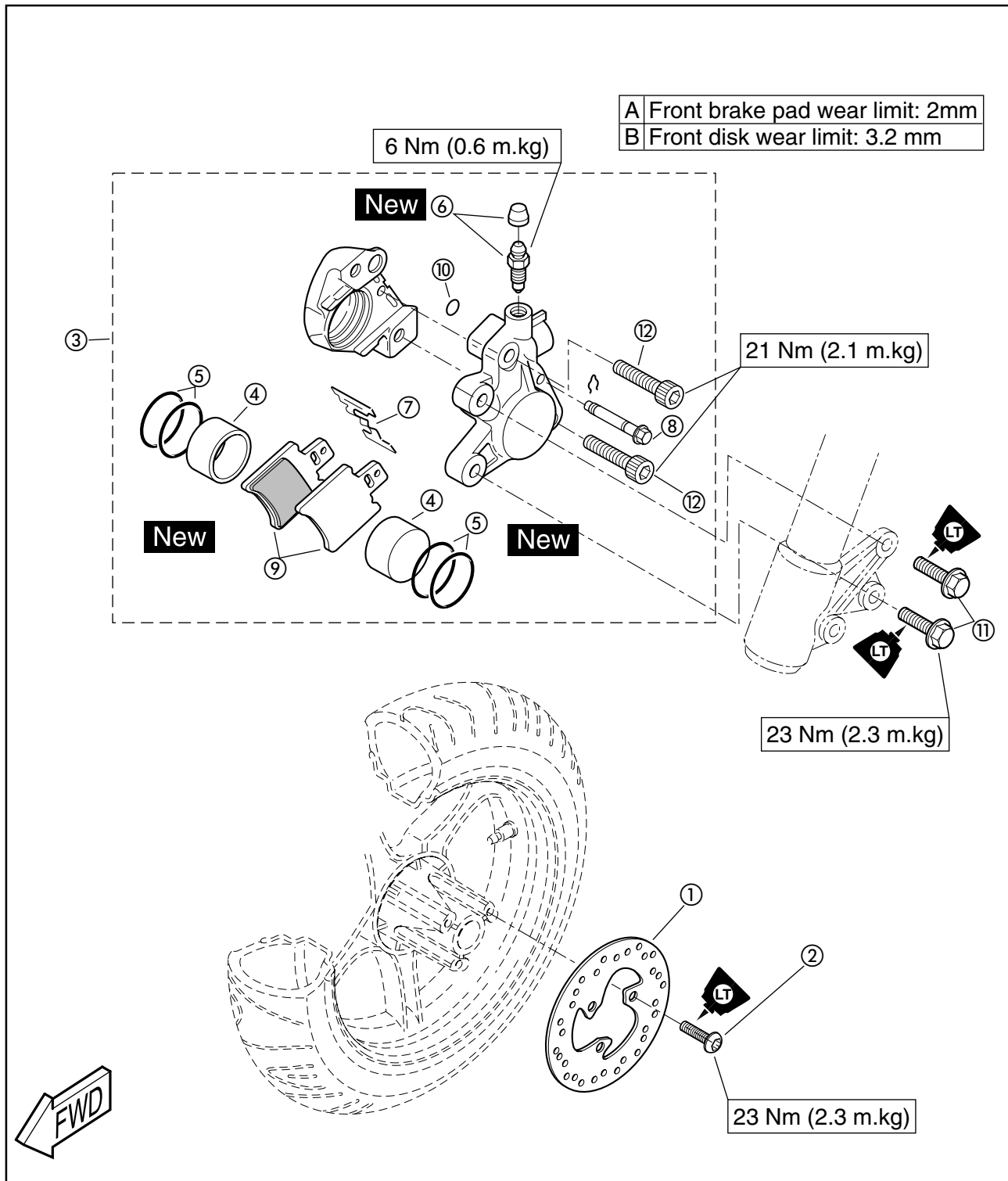

FRONT MASTER CYLINDER

- ① Master cylinder
- ② Master cylinder piston ass'y
- ③ Diaphragm
- ④ Master cylinder cap
- ⑤ Master cylinder bracket
- ⑥ Copper washer
- ⑦ Union bolt
- ⑧ Brake hose
- ⑨ Union bolt
- ⑩ Front brake switch
- ⑪ Front brake lever

NOTE: _____
 Drain completely before removing the master cylinder.

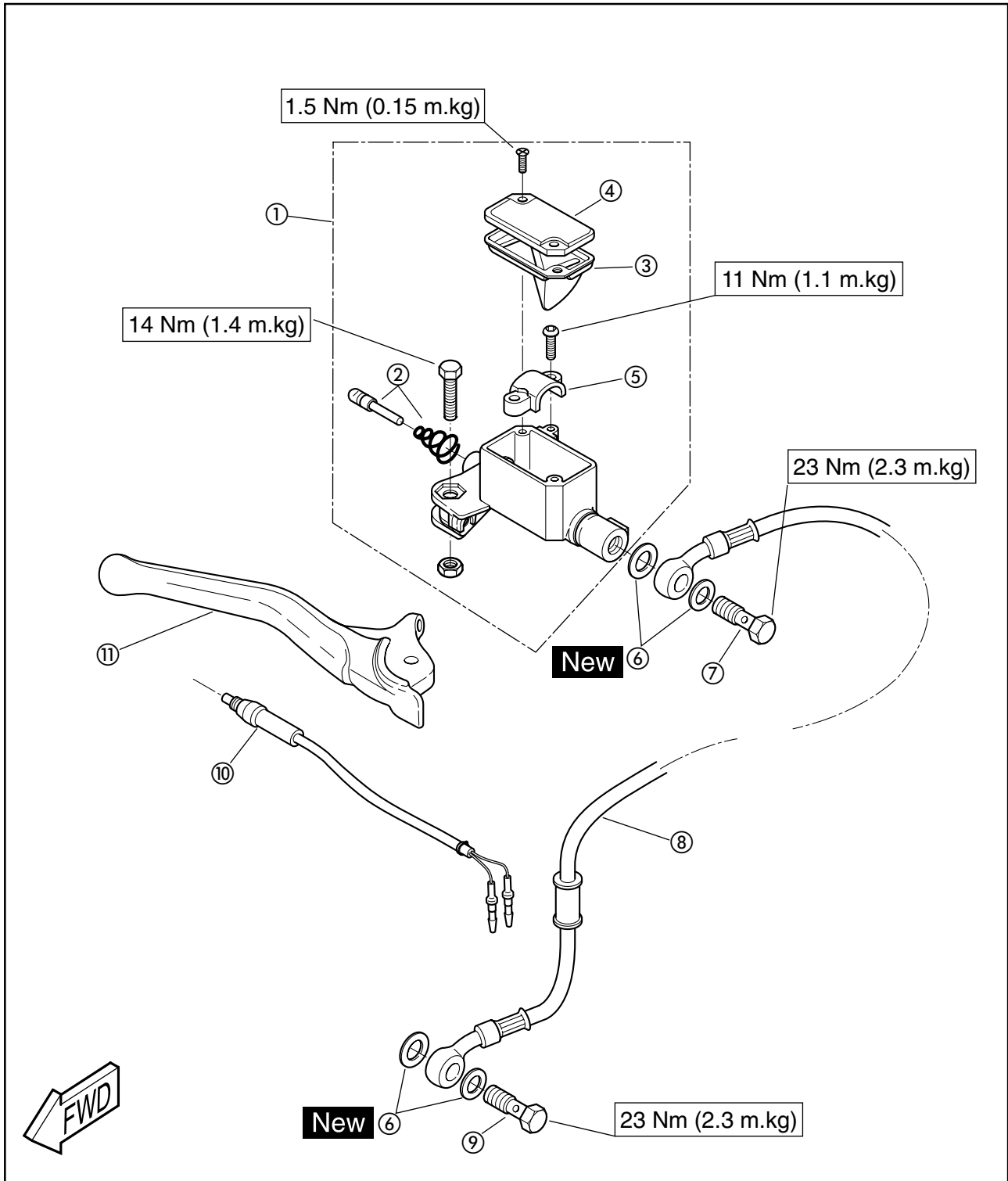

⚠ WARNING

- Disc brake components rarely require disassembly. Do not disassemble components unless absolutely necessary. If any hydraulic connection is disconnected, the entire system must be disassembled, drained, cleaned, and then properly filled and bled after reassembly. Do not use solvents on internal brake component.
- Solvents will cause seals to swell and distort. Use only clean brake fluid for cleaning. Use care with brake fluid. Never allow brake fluid to come in contact with the eyes. Brake fluid can damage painted surfaces and plastic parts.

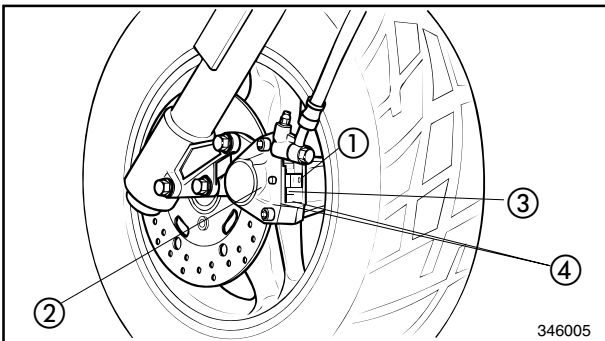
BRAKE PAD REPLACEMENT

It is not necessary to disassemble the brake caliper and brake hose to replace the brake pads.

1. Remove :

- Pin ①
- Axle ②

2. Remove :

- Pad spring ③
- Brake pads ④

NOTE:

Replace the brake pads as a set when either one is worn to the limit.

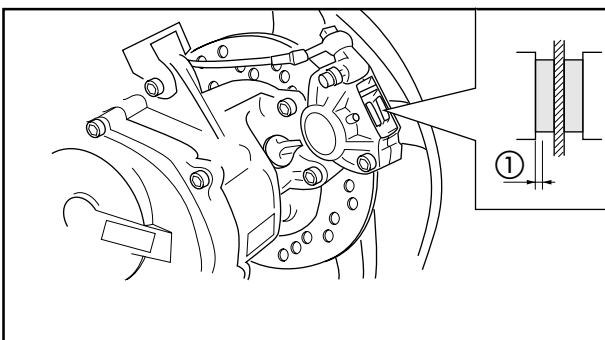

3. Measure :

- Brake pads

Out of specification → Replace.

NOTE:

Replace the brake pad and spring as a set when replacing the brake pads.



Wear limit ① :
2 mm (0.078 in)

FRONT BRAKE

CHAS



4. Install :

- Brake pads
- Pad spring
- Axle
- Pin

NOTE : _____

Be careful to install the brake pads correctly.

5. Lubricate :

- Mounting bolt (caliper body)



Recommended lubricant :
Lithium soap base grease

6. Install :

- Wheel axle
 - Mounting bolt (front caliper)
- Apply LOCTITE



LOCTITE ®



Wheel axle :
35 Nm (3.5 m.kg)
Mounting bolt :
21 Nm (2.1 m.kg)

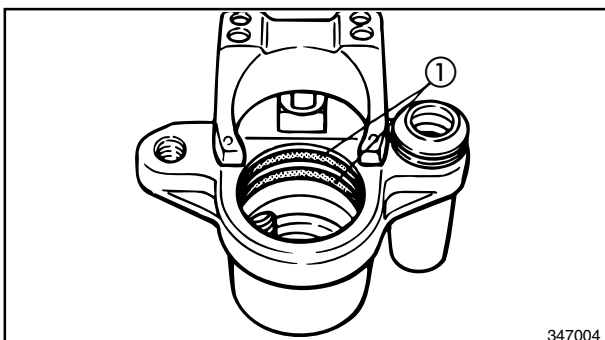
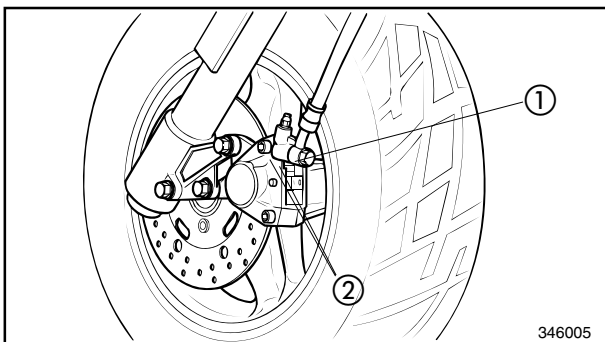

CALIPER DISASSEMBLY

NOTE: _____

Before disassembling the front brake caliper, drain all brake fluid from the brake hose, master cylinder, brake caliper and tank.

1. Remove:

- Union bolt ①
- Copper washers ②

NOTE: _____

Place the open end of the drain hose into a container and pump out the remaining brake fluid carefully.

2. Remove:

- Caliper body
- Caliper bracket

3. Remove :

- Piston
- Piston seals ①

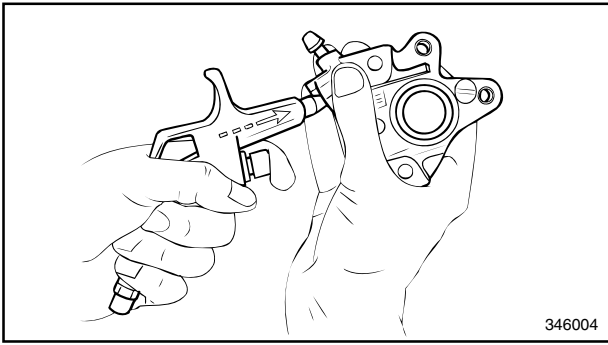

Removal steps :

- Blow compressed air into the hose joint opening to force out the piston from the caliper body.

⚠ WARNING

- Never try to pry out the piston.
- Cover the piston with a rag. Use care so that the piston does not cause injury as it is expelled from the cylinder.

- Remove the piston seals.

MASTER CYLINDER DISASSEMBLY

NOTE:

Before disassembling the front brake master cylinder, drain all brake fluid from the brake hose, master cylinder, brake caliper and tank.

1. Remove:

- Upper handlebar cover

2. Remove:

- Brake switch
- Brake lever
- Union bolt
- Copper washer

3. Remove:

- Master cylinder holder
- Master cylinder

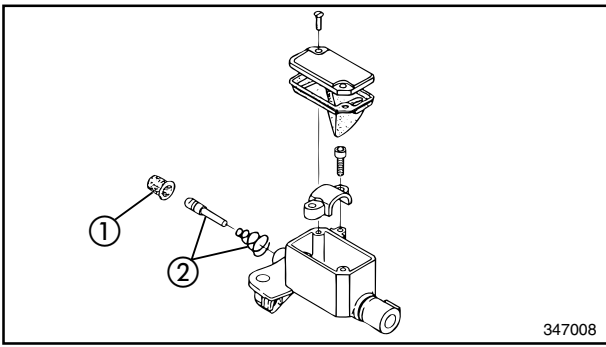

4. Remove :

- Master cylinder dust boot ①
- Master cylinder kit ②

INSPECTION AND REPAIR

Recommended brake component replacement schedule :

Brake pads	As required
Piston seal, Dust seal	Every two years
Brake hoses	Every four years
Brake fluid	Replace only when brakes are disassembled

⚠ WARNING

All internal parts should be cleaned in new brake fluid only. Do not use solvents as they will cause seals to swell and distort.

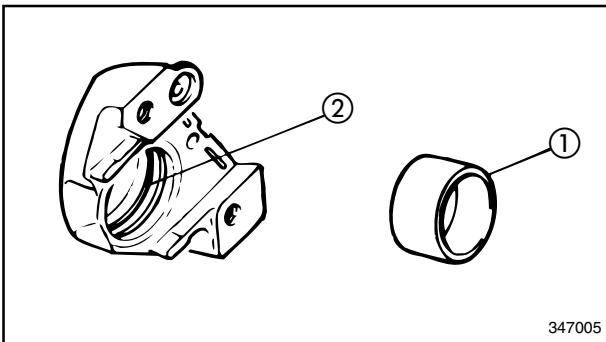

1. Inspect :

- Caliper piston ①
Scratches/Rust/Wear → Replace caliper assembly.
- Caliper body ②
Wear/Scratches/Cracks/Damage → Replace caliper assembly.

⚠ WARNING

Replace the piston seals whenever the caliper is disassembled.

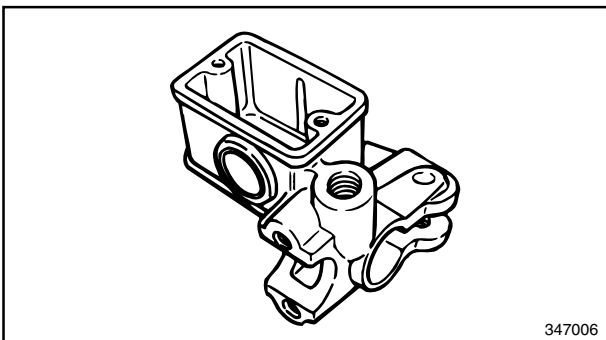

2. Inspect :

- Master cylinder
Wear/Scratches → Replace the master cylinder assembly.
- Master cylinder body/Diaphragm
Cracks/Damage → Replace.
- Master cylinder kit
Scratches/Wear/Damage → Replace as a set.

FRONT BRAKE

CHAS

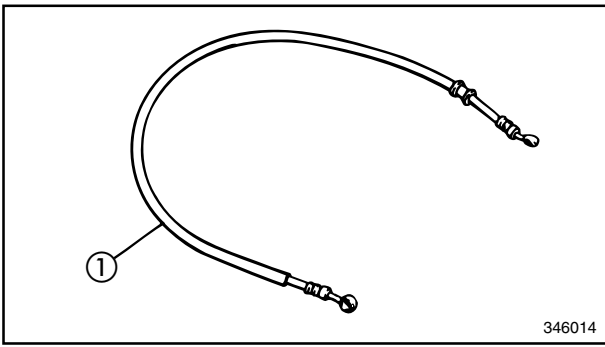

3. Check :

- Brake hose ①
Cracks/Wear/Damage → Replace.

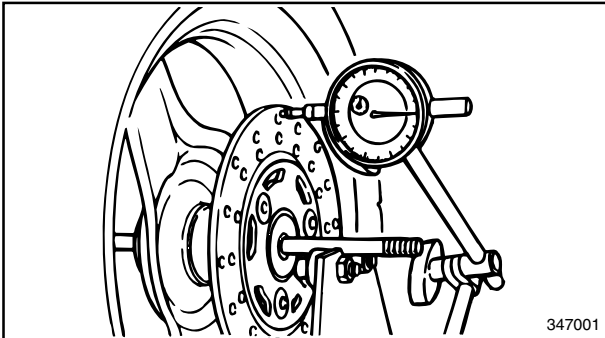

4. Measure :

- Brake disc deflection
Out of specification → Inspect wheel runout.
If wheel runout is good, replace the brake disc(s).



Maximum deflection :
0.25 mm (0.01 in)

- Brake disc thickness
Out of specification → Replace.



Minimum thickness :
3,2 mm (0.125 in)



Bolt (brake disc) :
23 Nm (2.3 m.kg)
LOCTITE®

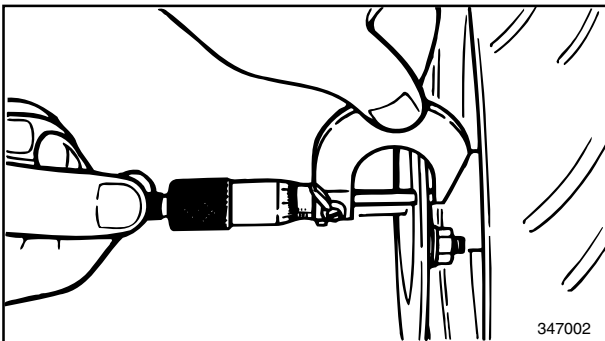

CALIPER ASSEMBLY

⚠ WARNING

- All internal parts should be cleaned in new brake fluid only.
- Internal parts should be lubricated with clean brake fluid when installed.



Recommended brake fluid :
DOT #3 or DOT #4

- Replace the piston seals whenever a caliper is disassembled.

1. Install :

- Piston seals ①
- Caliper piston ②

⚠ WARNING

Always use new piston seals.

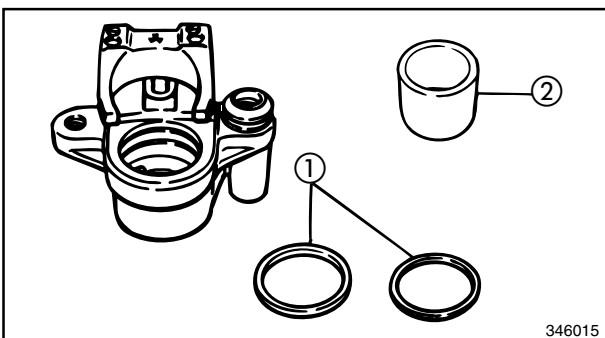

FRONT BRAKE

CHAS

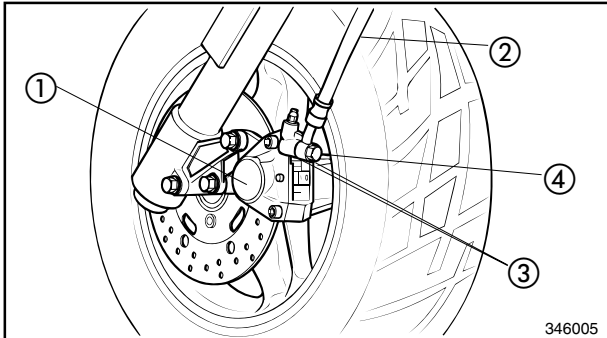

346005

2. Install :

- Brake caliper

Apply LOCTITE



LOCTITE®



Bolt (brake caliper) :
23 Nm (2.3 m.kg)

3. Install :

- Caliper body ①

4. Install :

- Brake hose ②
- Copper washers ③
- Union bolt ④



Union bolt :
23 Nm (2.3 m.kg)

CAUTION:

When installing the brake hose to the caliper, turn the brake pipe against the projection on the caliper.

⚠ WARNING

- Proper hose routing is essential to insure safe operation. Refer to "CABLE ROUTING".
- Always use new copper washers.

MASTER CYLINDER ASSEMBLY

⚠ WARNING

- All internal parts should be cleaned in new brake fluid only.
- Internal parts should be lubricated with clean brake fluid when installed.



Recommended brake fluid :
DOT #3 or DOT #4

FRONT BRAKE

CHAS

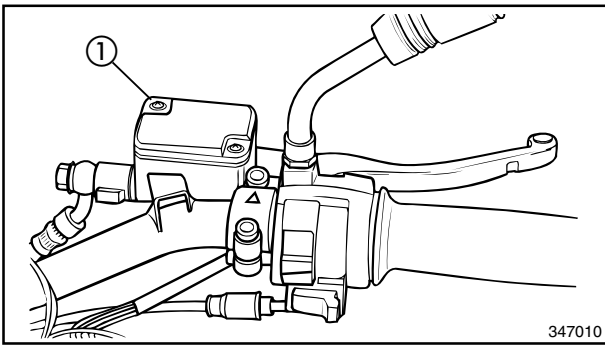

1. Install :
 - Master cylinder ①

CAUTION:

- Install the master cylinder holder with the arrow mark pointing upwards.
- Tighten the upper bolt first, then the lower bolt.



Bolt (master cylinder holder) :
1.1 Nm (0.11 m.kg)

2. Install :
 - Brake lever

NOTE:

Apply lithium soap base grease to the brake lever pivot.

3. Install :
 - Brake hose
 - Copper washers
 - Union bolts
 - Brake switch



Union bolt :
23 Nm (2.3 m.kg)

⚠ WARNING

- Proper hose routing is essential to insure safe operation. Refer to “CABLE ROUTING” in CHAPTER 2.
- Always use new copper washers.

4. Check that the brake hose does not touch other parts (throttle cable, wire harness, etc.) when the handlebar is turned to the left or right. Repair if necessary.



REAR WHEEL

- ① Cover plug
- ② Nut
- ③ Washer
- ④ Bolt
- ⑤ Rear wheel tire
- ⑥ Valve
- ⑦ Rear rim
- ⑧ Distance collar
- ⑨ Rear brake disk

A	TIRE SIZE: 140/60 - 13
B	RIM RUNOUT LIMIT: VERTICAL: 1,0 mm LATERAL: 1,0 mm

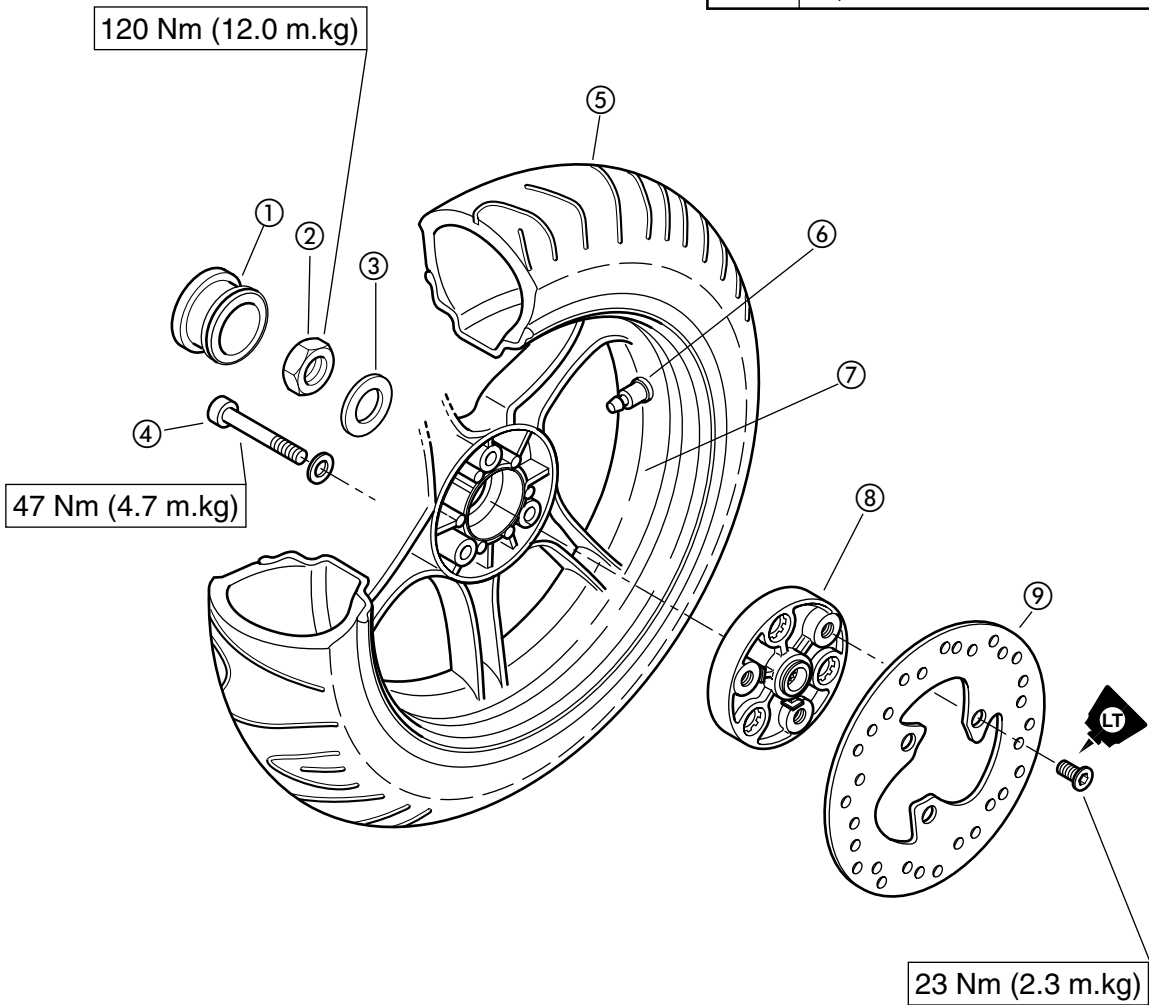



REAR MASTER CYLINDER

- ① Master cylinder
- ② Master cylinder piston ass'y
- ③ Diaphragm
- ④ Master cylinder cap
- ⑤ Master cylinder bracket
- ⑥ Copper washer
- ⑦ Union bolt
- ⑧ Brake hose
- ⑨ Union bolt
- ⑩ Rear brake switch
- ⑪ Rear brake lever

NOTE: _____
 Drain completely before removing
 the master cylinder.

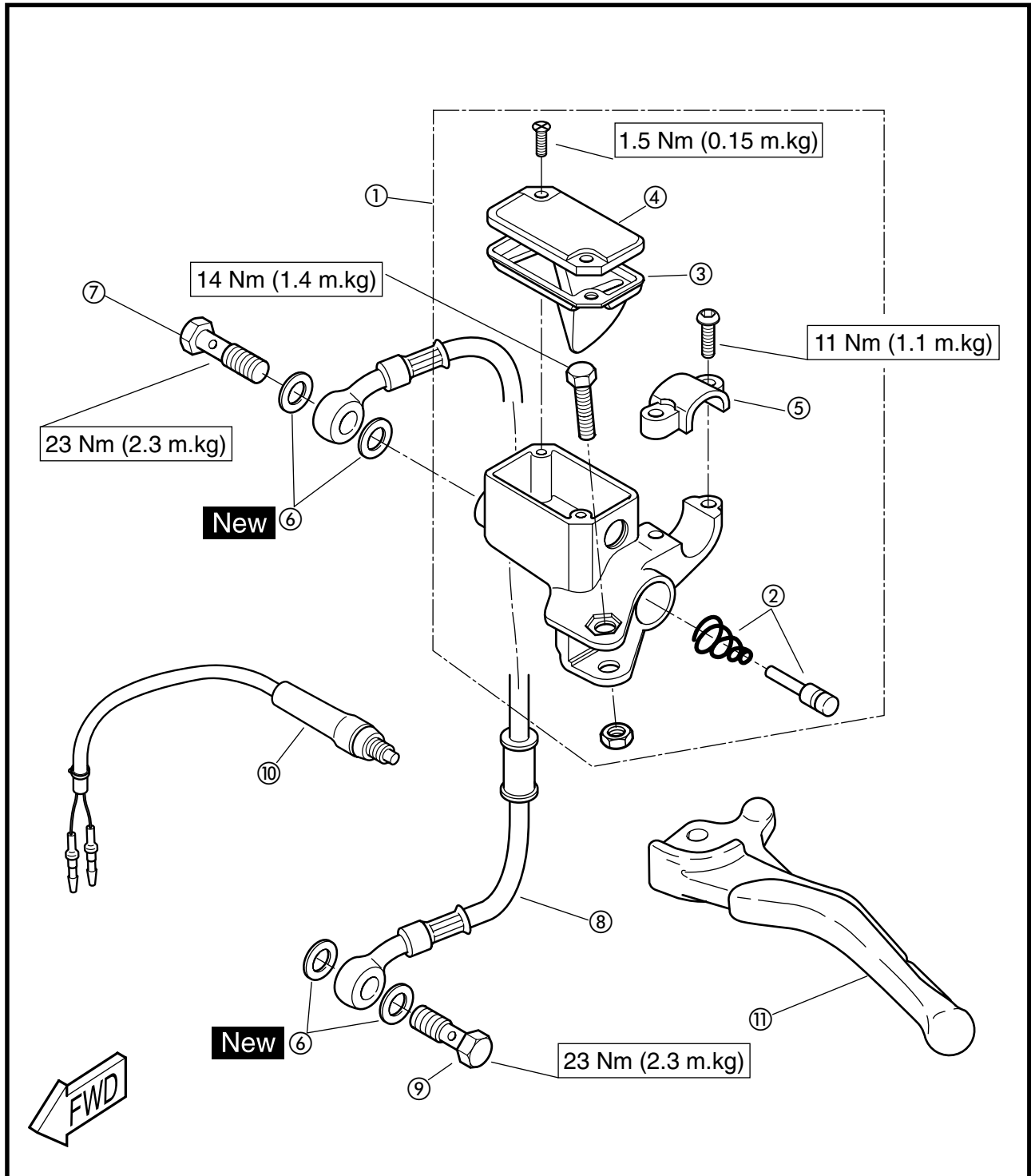



WARNING

- Disc brake components rarely require disassembly. Do not disassemble components unless absolutely necessary. If any hydraulic connection is disconnected, the entire system must be disassembled, drained, cleaned, and then properly filled and bled after reassembly. Do not use solvents on internal brake component.
- Solvents will cause seals to swell and distort. Use only clean brake fluid for cleaning. Use care with brake fluid. Never allow brake fluid to come in contact with the eyes. Brake fluid can damage painted surfaces and plastic parts.

REMOVAL

1. Remove:
 - Muffler assembly
 - Rear wheel fixing bolts
 - Rear wheel

INSPECTION

1. Check :
 - Rear wheelRefer to the section "FRONT WHEEL".

2. Measure :
 - Wheel runoutRefer to the section "FRONT WHEEL".

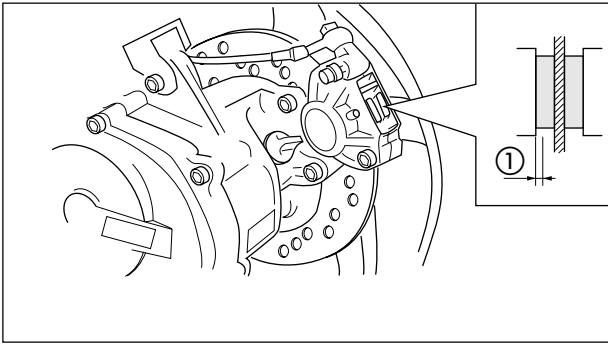

Rim runout limits :
Radial : 1.0 mm (0.039in)
Lateral : 1.0 mm (0.039 in)

**3. Check :**

- Wheel bearings

Refer to the section "FRONT WHEEL INSPECTION".

REAR BRAKE

For removal, inspection and assembly refer to the section "FRONT BRAKE"

INSTALLATION

Reverse the REMOVAL procedure.

Note the following points.

1. Install

- Rear wheel

2. Tighten :

- Rear wheel fixing bolts



Rear wheel fixing bolt :
47 Nm (4.7 m.kg)

3. Install :

- Muffler



Bolt (exhaust pipe) :
7 Nm (0.7 m.kg)

Bolt (muffler) :
29 Nm (2.9 m.kg)

4. Adjust :

- Rear brake lever free play.

Refer to the section "REAR BRAKE LEVER FREE PLAY ADJUSTMENT" in CHAPTER 3.



FRONT FORK

- ① Steering bracket
- ② Bolt
- ③ Circlip
- ④ Rubber cap
- ⑤ Circlip
- ⑥ Spring seat
- ⑦ O-Ring
- ⑧ Spring
- ⑨ Piston
- ⑩ Spring
- ⑪ Spacer
- ⑫ Plunger
- ⑬ Dust boot
- ⑭ Retainer
- ⑮ Oil seal
- ⑯ Outer fork tube
- ⑰ Washer
- ⑱ Screw

A	Oil capacity of each fork leg: 75 cc
B	Oil grade: ISO 6743/4 - LHV 46 or SAE10

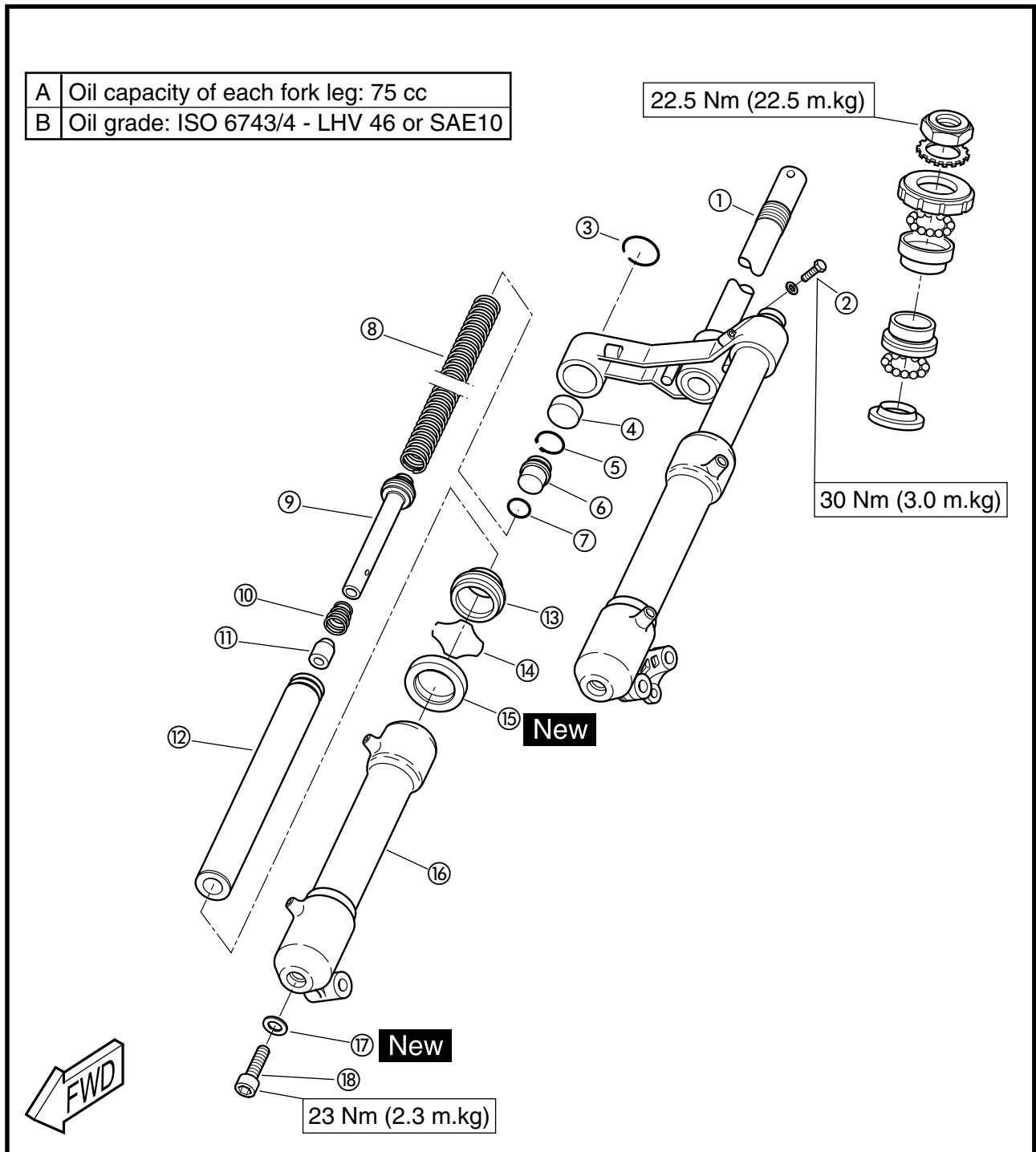

REMOVAL

WARNING

Securely support the scooter with a stand under the engine.

1. Place the scooter on an even surface.

2. Disconnect :

- Speedometer cable

3. Remove :

- Front wheel

Refer to section "FRONT WHEEL" in Chapter 7.

4. Remove :

- Front fender

Refer to section "COVERS - REMOVAL AND INSTALLATION" in Chapter 3.

5. Remove :

- Steering head

Refer to section "STEERING HEAD AND HANDLEBAR" in Chapter 7.

6. Remove :

- Nut ①
- Washer ②
- Ring nut ③

NOTE:

- Loosen the ring nut with the ring nut wrench ④.

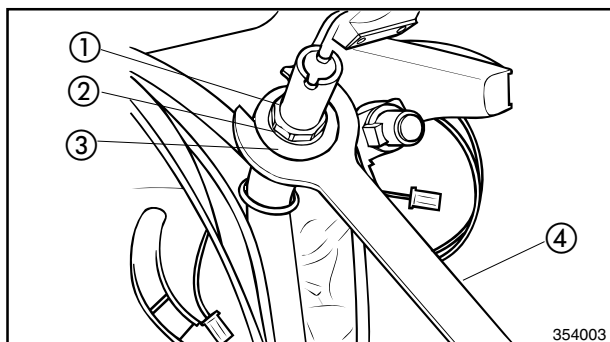

Ring nut wrench :
9079Q-02218

- Support the steering shaft to prevent it from falling.

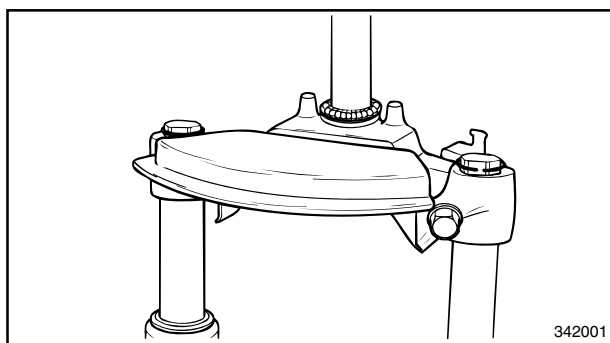

7. Remove :

- Front fork assembly
- Bearing balls

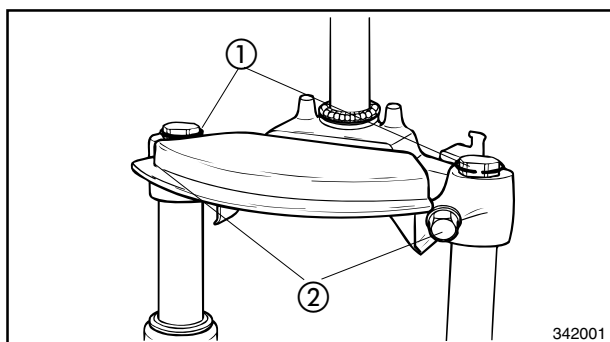

8. Remove :

- Circlip ①

9. Loosen :

- Pinch bolt ②

10. Remove :

- Fork leg (complete)

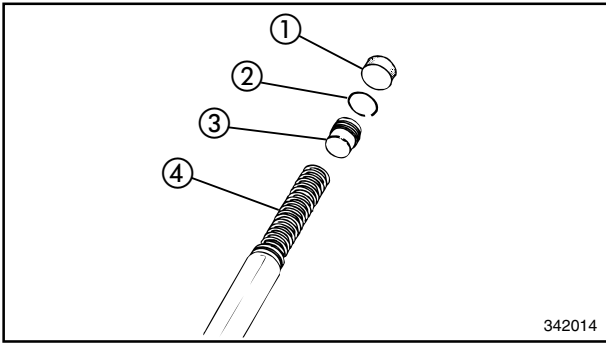

DISASSEMBLY

1. Remove :

- Rubber plug ①
- Circlip ②
- Spring seat ③
- Spring ④

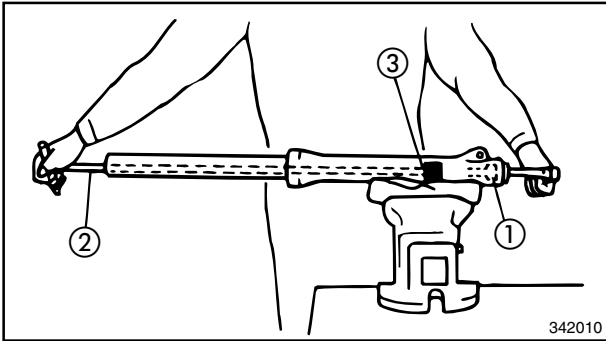

2. Remove :

- Bolt ①
- Copper washer

NOTE:

To remove the drain bolt ①, use the T-handle ② and the holder ③.



T-handle for front fork :
90890-01326
Holder :
90890-01294

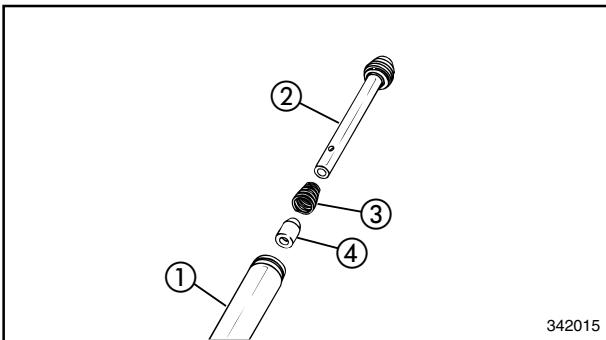

3. Remove :

- Inner fork tube ①
- Piston ②
- Spring ③
- Spring seat ④

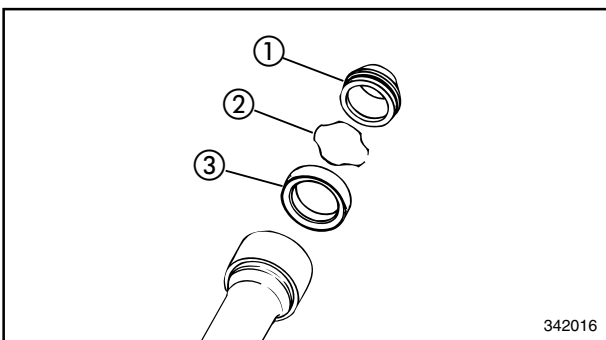

4. Remove :

- Dust boot ①
- Retainer ②
- Oil seal ③

INSPECTION

1. Check :
 - Inner fork tube and fork components
 - Outer fork tube
 - Wear/Scratches/Damage → Replace.

⚠ WARNING

Never attempt to straighten a bent fork tube as this may dangerously weaken the tube.

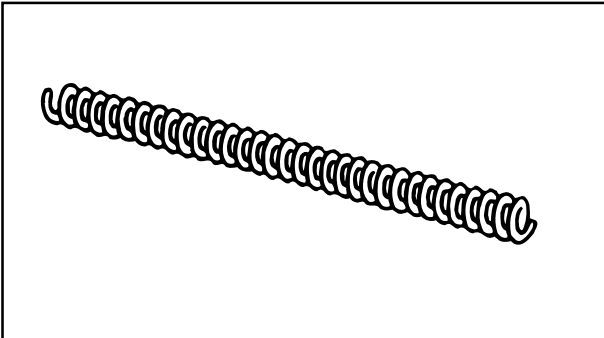

2. Measure :
 - Fork spring free length ①
 - Used/bends/Damage → Replace.

ASSEMBLY

Reverse the “DISASSEMBLY” procedure.
Note the following points.

NOTE: _____

- When reassembling the front fork, make sure you use following new parts:
 - Oil seals
 - Circlips and retainers
- Make sure that all components are clean before reassembling.

1. Install :

- Oil seal
- Retainer
- Dust boot

NOTE: _____

Before installing the oil seal, apply lithium soap grease onto the oil seal lips.

2. Install :

- Inner fork tube
- Spring seat
- Spring
- Piston

FRONT FORK

CHAS

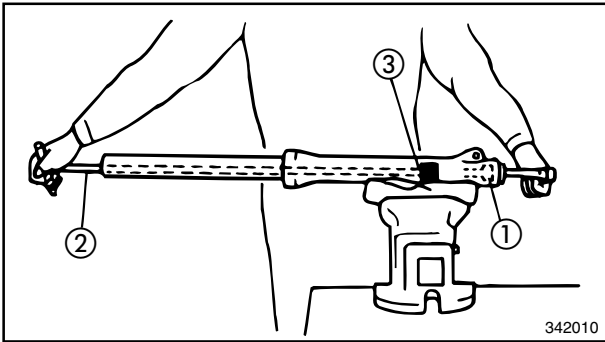

3. Install :
- Copper washer
 - Bolt

NOTE:

Tighten the drain bolt (1) while holding the piston with the T-handle (2) and holder (3).



T-handle for front fork :
90890-01326
Holder :
90890-01294

4. Fill :
- Fork oil



Fork oil type :
ISO 6743/4-LHV 46 or SAE 10
Amount (per fork tube):
75 cc

5. Install :
- Spring
 - Spring seat
 - Circlip
 - Rubber plug

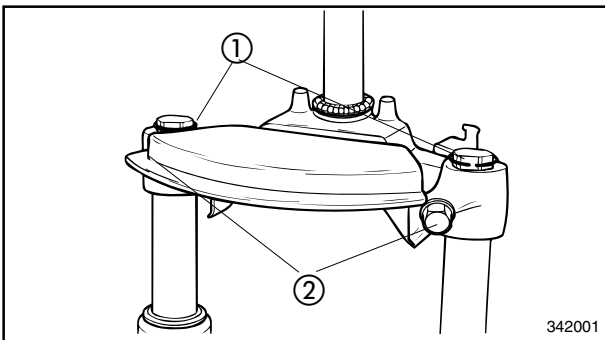

INSTALLATION

Reverse the "REMOVAL" procedure.
Note the following points.

1. Install :
- Left and right fork tube into the steering crown.
2. Install :
- Circlips (1)
3. Install :
- Pinch bolts (2)



Pinch bolt :
30 Nm (3.0 m.kg)



STEERING HEAD AND HANDLEBAR

- ① Handlebar
- ② Nut
- ③ Bolt
- ④ Trottle grip
- ⑤ Throttle cable
- ⑥ Starter cable (Choke)

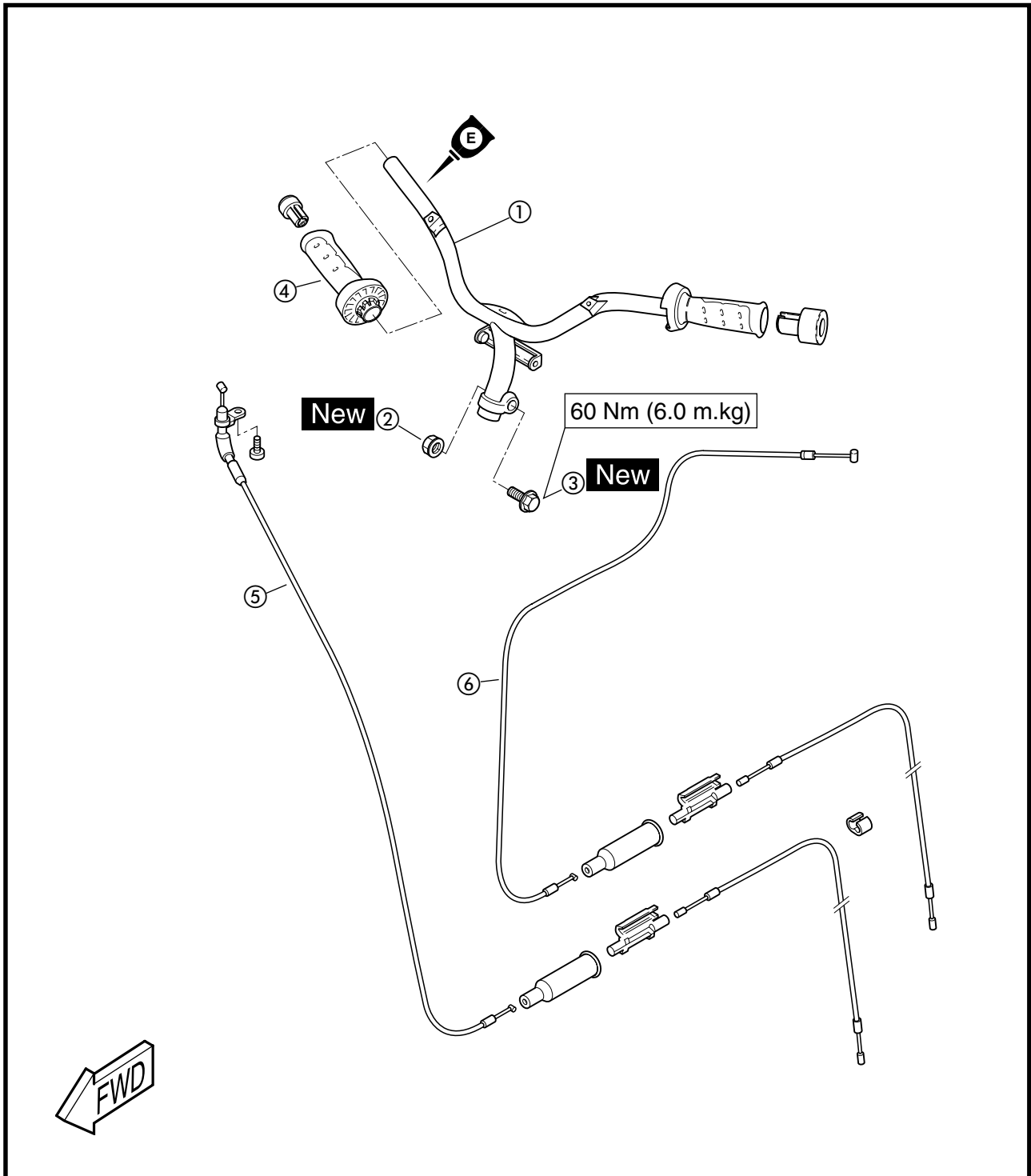

STEERING HEAD AND HANDLEBAR

REMOVAL

⚠ WARNING

Securely support the scooter so there is no danger of it falling over.

1. Place the scooter on an even surface.

2. Remove :

- Front fender
- Inner panels
- Upper handlebar cover

Refer to section “REMOVAL AND INSTALLATION OF COVERS” in Chapter 3.

3. Drain :

- Front and rear brakes system

Refer to section “FRONT BRAKE” in Chapter 6.

4. Remove :

- Front and rear brakes master cylinder

Refer to section “FRONT BRAKE” in Chapter 6.

5. Remove :

- Front and rear brakes calipers mounting bolts

6. Remove :

- Front wheel

Refer to section “FRONT BRAKE” in Chapter 6.

7. Remove :

- Throttle grip

8. Disconnect :

- Ground wire
- All couplers
- Wire harness band
- Clamp

9. Remove :

- Nut ①
- Bolt
- Handlebar

10. Remove :

- Ring nut
- Washer

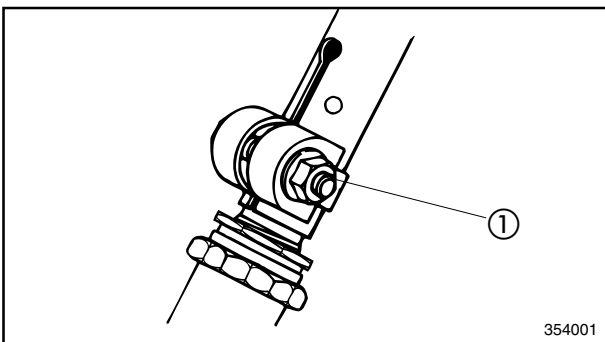

STEERING HEAD AND HANDLEBAR

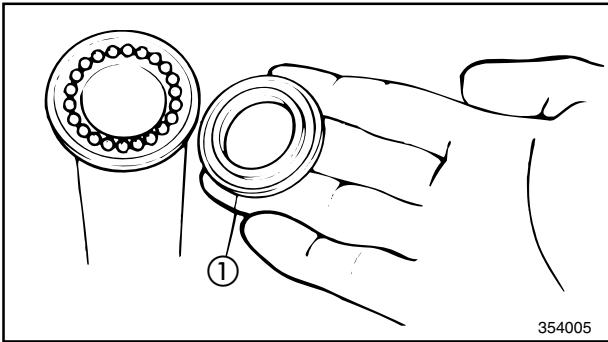

11. Remove :
- Upper bearing race ①

	Ring nut wrench : 9079Q-02218
--	--

- Steering shaft
- Bearing balls

INSPECTION

1. Check :
- Handlebar ①
Bends/Cracks/Damage → Replace.

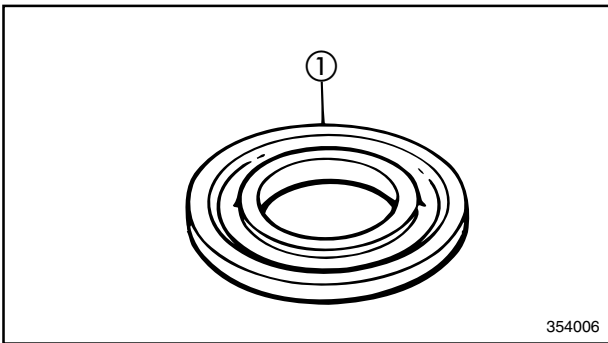

2. Wash the bearing balls in solvent.

3. Check :
- Bearing races ①
Pitting/Damage → Replace.
 - Bearing balls
Pitting/Damage → Replace.

NOTE: _____
Always replace the bearing balls and the upper and lower bearing races as a set.

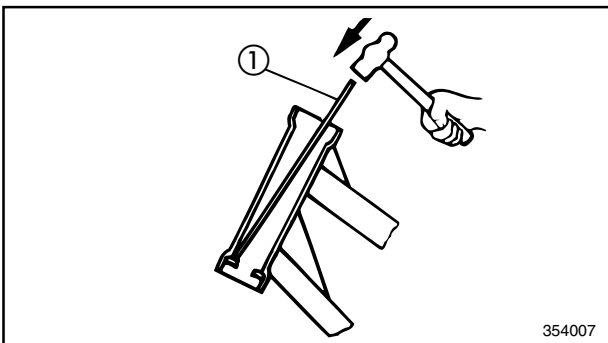

- *****
- Bearing race replacement steps :**
- Drive out the bearing race from the steering tube by hitting on it in several places.
 - Remove the bearing race on the steering shaft with a hammer and a chisel ① as shown.
 - Drive in the new bearing races evenly by hitting on them in several places.

STEERING HEAD AND HANDLEBAR

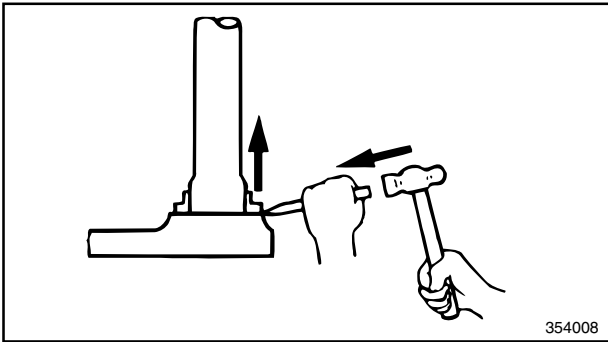
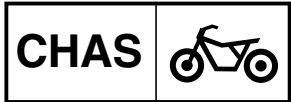

CAUTION:

- Unless installed correctly, the bearing races will damage the frame.
- Never hit the bearing races on the ball race surface.

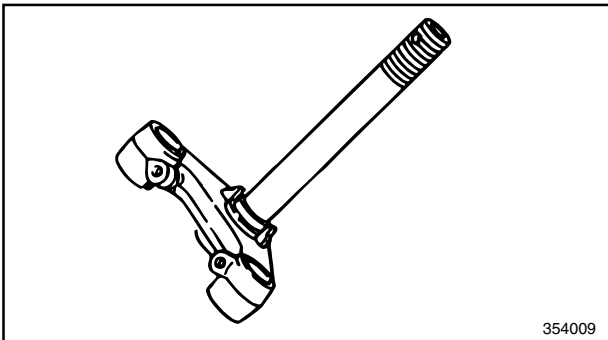

4. Check :
- Steering shaft
Bend/Damage → Replace.

⚠ WARNING

Never attempt to straighten a bent steering shaft.

ASSEMBLY AND INSTALLATION

Reverse the “REMOVAL” and “DISASSEMBLY” procedure.

Note the following points.

⚠ WARNING

Proper cable and hose routing is essential to insure safe scooter operation. Refer to section “CABLE ROUTING” in Chapter 3.

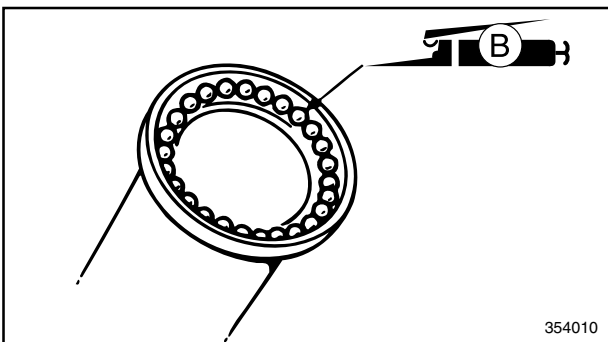

1. Install :
- Bearing balls

2. Apply :
- Bearing grease (onto upper and lower bearing balls)

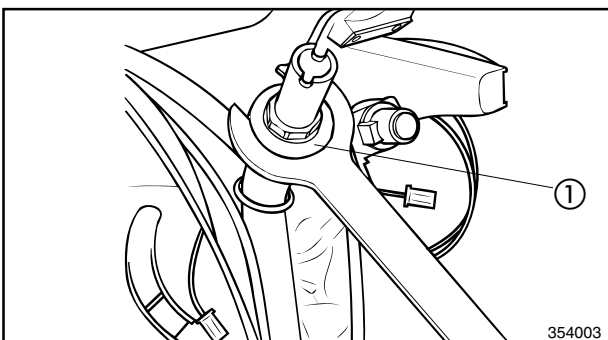

3. Install :
- Steering shaft
 - Bearing race (upper) ①

	Ring nut wrench : 9079Q-02218
--	---

STEERING HEAD AND HANDLEBAR

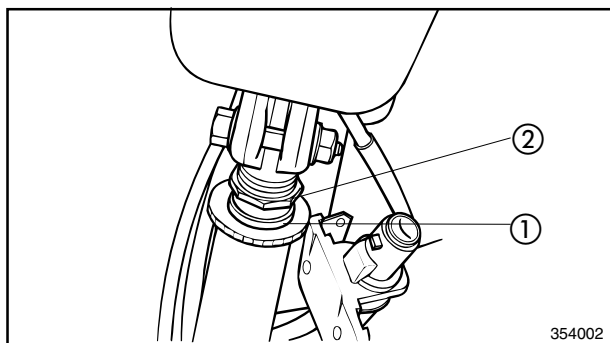
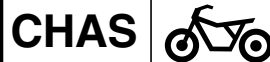

CAUTION:

Hold the steering shaft until it is securely attached.

4. Install :

- Washer ①
- Steering shaft lock nut ②

NOTE:

Tighten the steering shaft lock nut with the ring nut wrench. Set the torque wrench to the ring nut wrench so that they form a right angle.



Ring nut wrench :
9079Q-02218



Steering shaft ring nut :
22.5 Nm (2.25 m.kg)

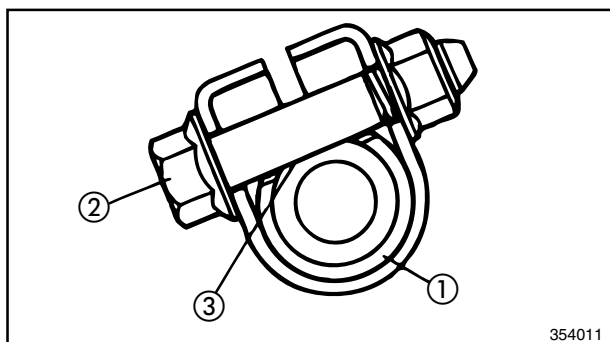

5. Install :

- Handlebar ①
- Bolt ② (new)
- Nut ③ (new)

NOTE:

- Install the handlebar onto the steering shaft notch.
- Install the wire harness, the throttle cable, the speedometer cable and the rear brake cable.

6. Install :

- Throttle grip (complete)
- Master cylinder
- Brake hose (into the clip)

CAUTION:

- Before installing the handlebar, wipe off any trace of oil from the inserted section of the shaft with solvent.
- Insert the bolt from the left as shown.



Bolt (handlebar) :
60 Nm (6.0 m.kg)

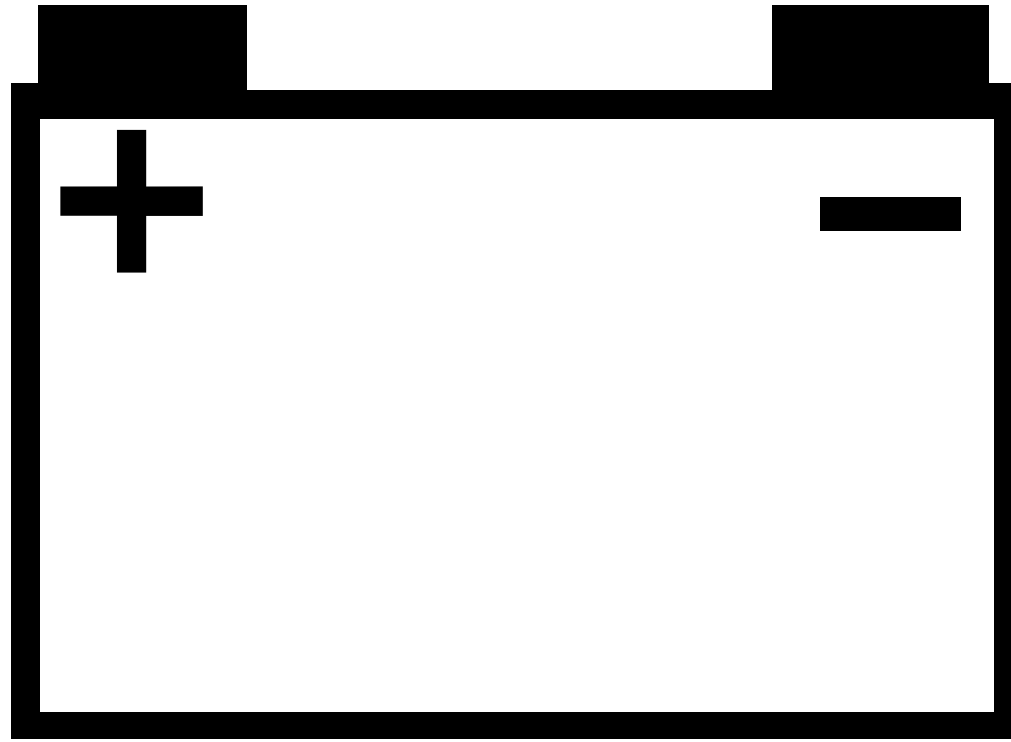

ELEEC

88

CHAPTER 8. ELECTRICAL COMPONENTS

ELECTRICAL COMPONENTS	8-1
CIRCUIT DIAGRAM	8-3
IGNITION AND STARTING SYSTEM	8-5
CIRCUIT DIAGRAM	8-5
IGNITION AND STARTING SYSTEM CIRCUIT DIAGRAM	8-6
TROUBLESHOOTING	8-7
CHARGING SYSTEM	8-13
CIRCUIT DIAGRAM	8-13
TROUBLESHOOTING	8-14
LIGHTING SYSTEM	8-16
CIRCUIT DIAGRAM	8-16
TROUBLESHOOTING	8-17
SIGNAL SYSTEM	8-21
WIRING DIAGRAM	8-21
TROUBLESHOOTING	8-22
COOLING SYSTEM	8-30
CIRCUIT DIAGRAM	8-30
TROUBLESHOOTING	8-31



ELECTRICAL SYSTEM

ELECTRICAL COMPONENTS

- ① Wire harness
- ② Fuel sender
- ③ Starter relay
- ④ Ignition coil
- ⑤ CDI unit
- ⑥ Oil sender
- ⑦ Battery
- ⑧ Resistance

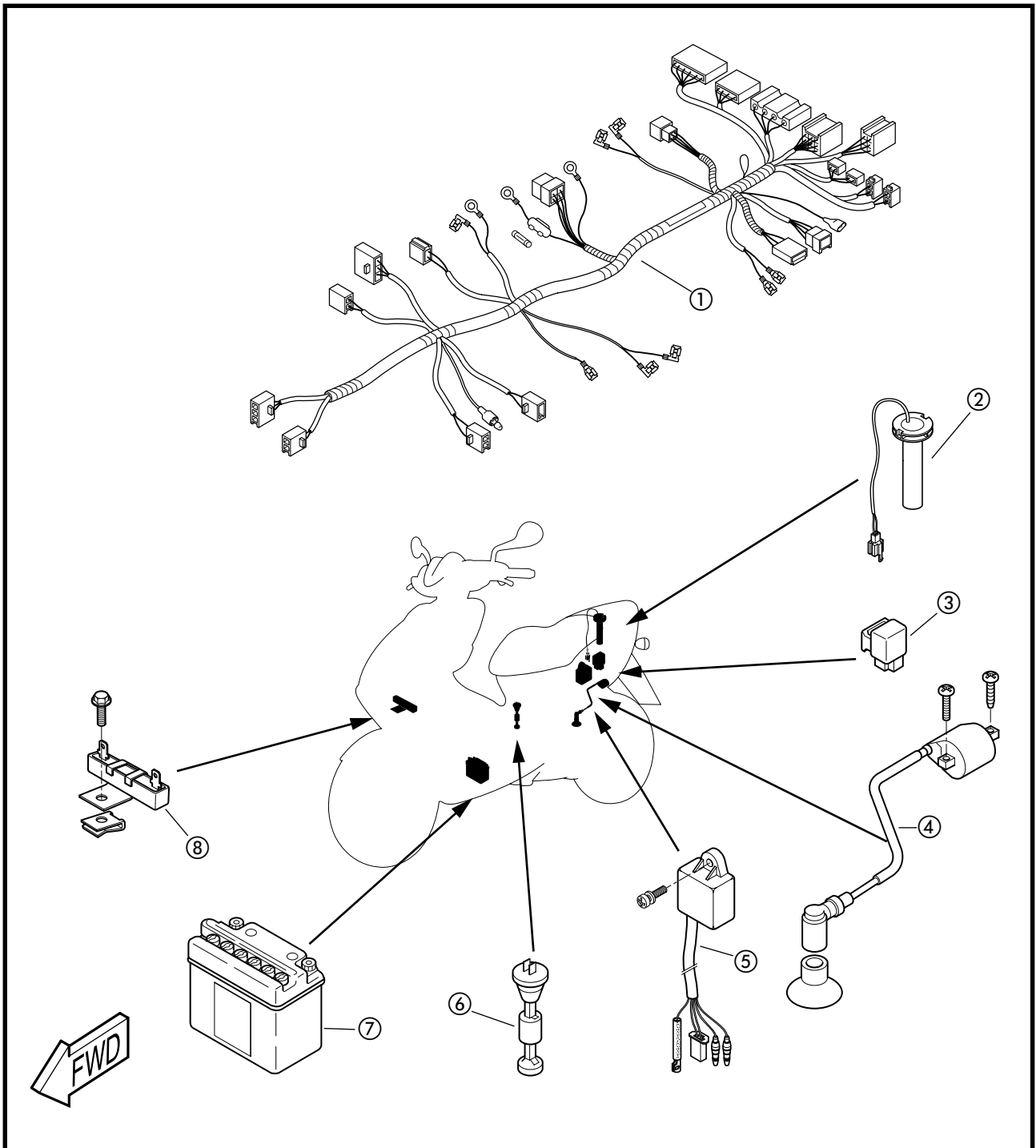

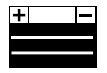

ELECTRICAL COMPONENTS

- ① Main switch
- ② Flasher relay
- ③ Horn
- ④ Rectifier/Regulator

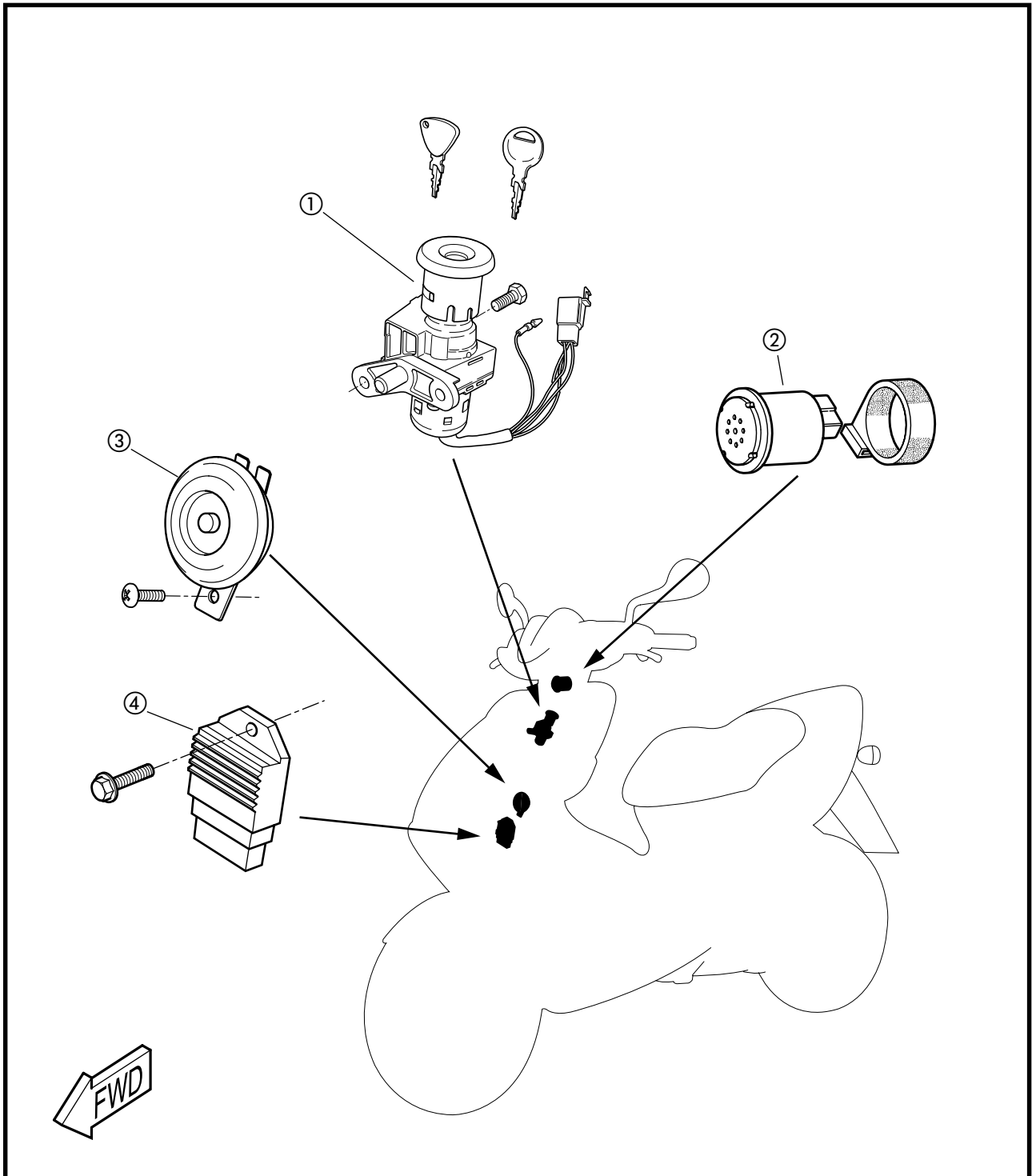

CIRCUIT DIAGRAM

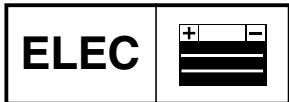

- | | |
|---|--|
| <ul style="list-style-type: none"> ① Spark plug ② Ignition coil ③ CDI magneto ④ CDI unit ⑤ Rectifier/regulator ⑥ Dimmer switch ⑦ Starter motor ⑧ Starter relay ⑨ Fuse ⑩ Battery ⑪ Starter switch ⑫ Main switch ⑬ Lighting switch ⑭ "HIGH BEAM indicator" ⑮ Head light ⑯ Meter light ⑰ Tail/Stop light ⑱ Front stop switch | <ul style="list-style-type: none"> ⑲ Rear stop switch ⑳ Flasher relay ㉑ Flasher switch ㉒ Flasher indicator ㉓ Rear flasher light (Left) ㉔ Front flasher light (Left) ㉕ Front flasher light (Right) ㉖ Rear flasher light (Right) ㉗ Horn ㉘ Horn switch ㉙ Oil lever indicator ㉚ Oil lever gauge ㉛ Fuel meter ㉜ Sender ㉝ Position light ㉞ Resistor ㉟ Water temperature indicator ㊱ Water sender |
|---|--|

COLOR CODE

R	Red	L	Blue
B	Black	Y/R	Yellow/Red
W	White	L/W	Blue/White
Y	Yellow	G/Y	Green/Yellow
Br	Brown	B/W	Black/White
Gy	Gray	B/R	Black/Red
O	Orange	W/R	White/Red
Ch	Chocolate	Br/W	Brown/White
Dg	Dark green	Y/B	Yellow/Black
G	Green	G/W	Green/White
P	Pink		

IGNITION AND STARTING SYSTEM

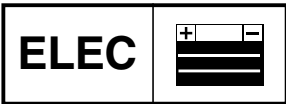

IGNITION AND STARTING SYSTEM CIRCUIT DIAGRAM

- | | | |
|------------------|----------------------|------------------------------|
| ① Spark plug | ⑫ Main switch | a Source coil |
| ② Ignition coil | ⑬ Front brake switch | b Pickup coil |
| ④ CDI unit | ⑭ Rear brake switch | c Wave-shape shaping circuit |
| ⑦ Starter Motor | | d Condenser |
| ⑧ Starter relay | | e Diode |
| ⑨ Fuse | | f SCR |
| ⑩ Battery | | g To oil level switch |
| ⑪ Starter switch | | |

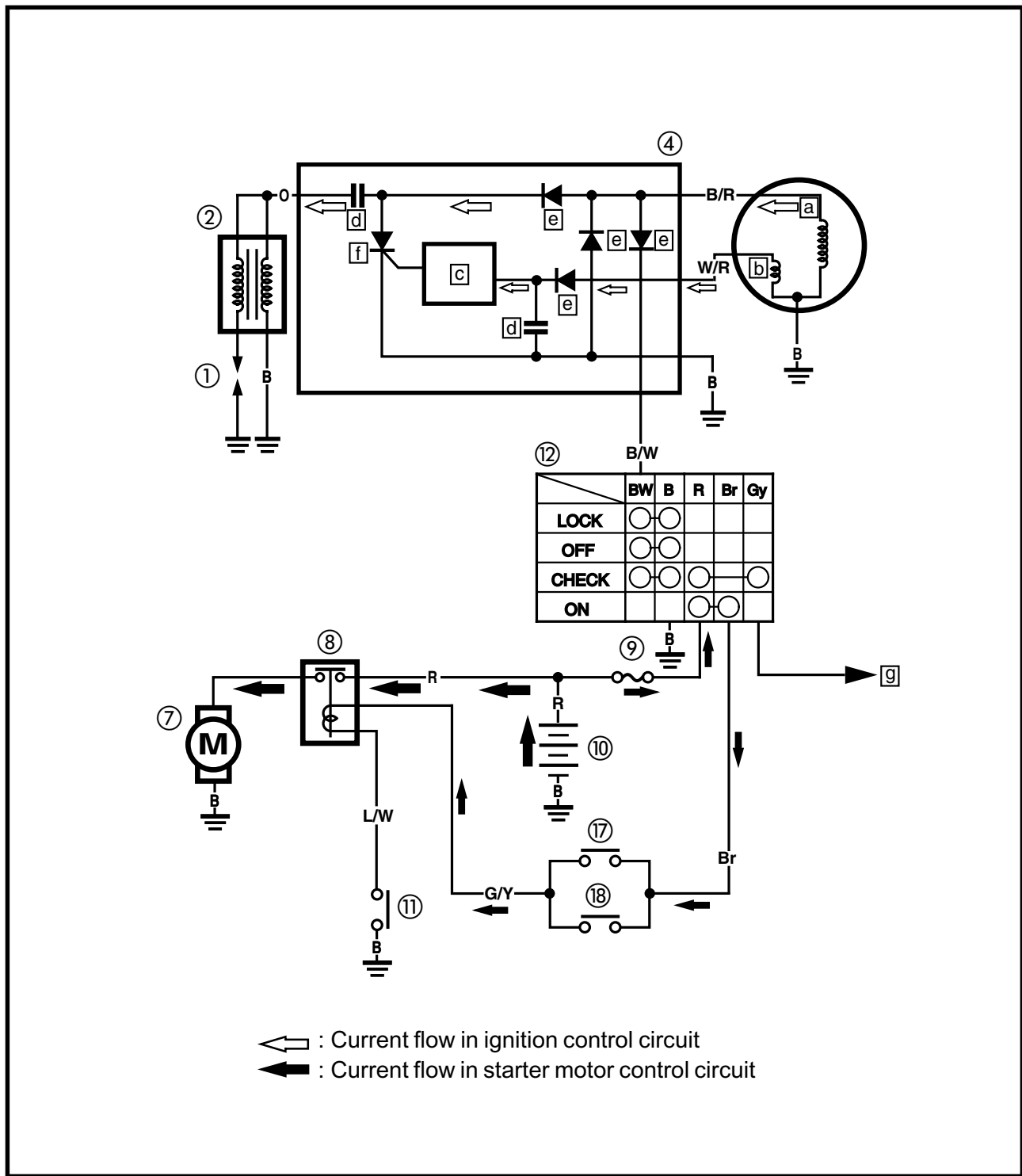

TROUBLESHOOTING

**THE STARTING SYSTEM DOES NOT WORK
(NO SPARK OR IRREGULAR SPARKS).**

NOTE :

- Remove the following parts before proceeding with the troubleshooting :
 - 1) Side covers (left and right)
- For accurate troubleshooting use the following special tools :

	Ignition checker : 90890-06754
---	---

	Pocket tester : 90890-03112
---	--

1. Spark plug	
<ul style="list-style-type: none"> • Check the spark plug type. • Check the condition of the spark plug. • Check the spark plug gap. Refer to "SPARK PLUG INSPECTION" in Chapter 3. 	
Standard spark plug : BR8HS (NGK)	
	Spark plug gap : 0.5 ~ 0.7 mm (0.019 ~ 0.028 in)

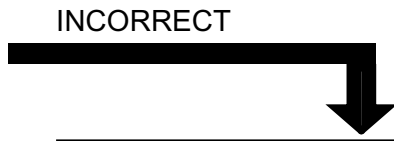

The spark plug is defective. Replace it or adjust the spark plug gap.



2. Spark check	
<ul style="list-style-type: none"> • Remove the spark plug cap. • Connect the ignition checker ①. <li style="padding-left: 20px;">② Spark plug cap <li style="padding-left: 20px;">③ Spark • Check the length of the spark gap. • Start the engine and increase the spark length until the engine begins to misfire. 	
	Minimum spark gap : 6.0 mm (0.24 in)

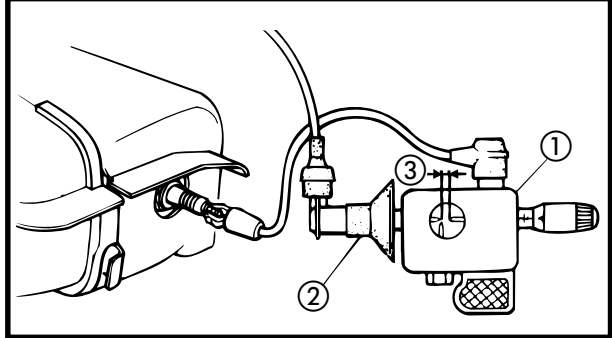

OUT OF SPECIFICATION
OR NO SPARK



Ignition system in good condition.

3. Spark plug cap resistance

- Disconnect the spark plug cap.
- Connect the pocket tester ($\Omega \times 1 \text{ k}$) to the spark plug cap.
- Check the resistance of the spark plug cap.



Spark plug cap resistance :
 $5\text{k}\Omega$ at 20°C (68°F)

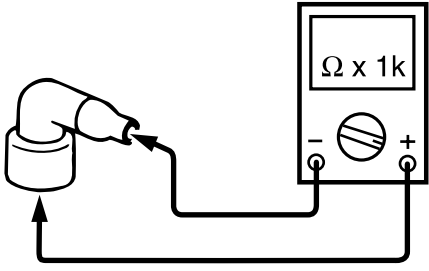

 MEETS SPECIFICATION

DOES NOT MEET SPECIFICATION



Replace the spark plug cap

4. Ignition coil resistance

- Disconnect the ignition coil leads.
- Connect the pocket tester ($\Omega \times 1$) to the ignition coil.

Ignition coil :
Pocket tester (+) lead → Orange
Pocket tester (-) lead → Ground

- Check the primary coil resistance.



Primary coil resistance :
 $0.32 \sim 0.48 \Omega$ at 20°C (68°F)

- Connect the pocket tester ($\Omega \times 1\text{k}$) to the ignition coil.

Pocket tester (+) lead → Ground
Pocket tester (-) lead → Spark plug lead

- Check the secondary coil resistance.



Secondary coil resistance :
 $5.68 \sim 8.52\text{k}\Omega$ at 20°C (68°F)

 MEETS SPECIFICATION

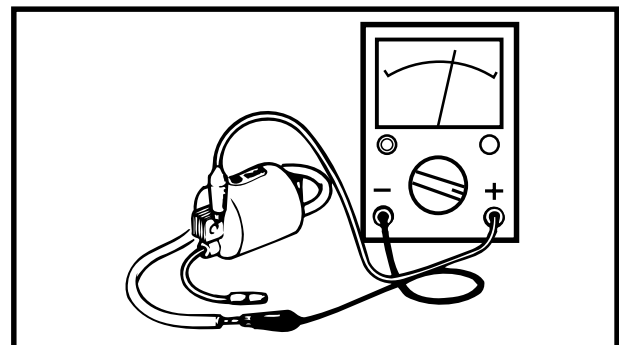
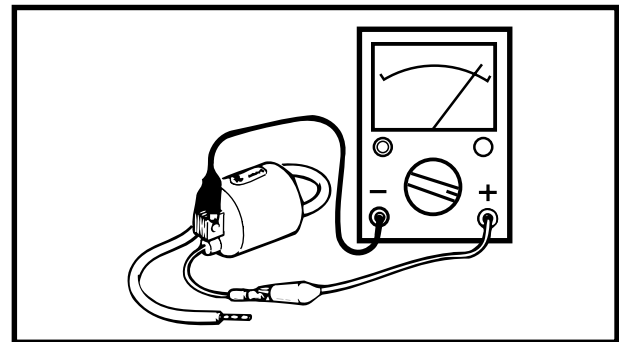

DOES NOT MEET SPECIFICATION



Defect. Replace the ignition coil.



5. Pickup coil resistance	
<ul style="list-style-type: none"> • Disconnect the pickup coil coupler. • Connect the pocket tester ($\Omega \times 100$) to the pickup coil. 	
Pocket tester (+) lead ① → White / Red Pocket tester (-) lead ② → Ground	
<ul style="list-style-type: none"> • Check the pickup coil resistance. 	
	Pickup coil resistance : 400 ~ 600 Ω at 20°C (68°F)

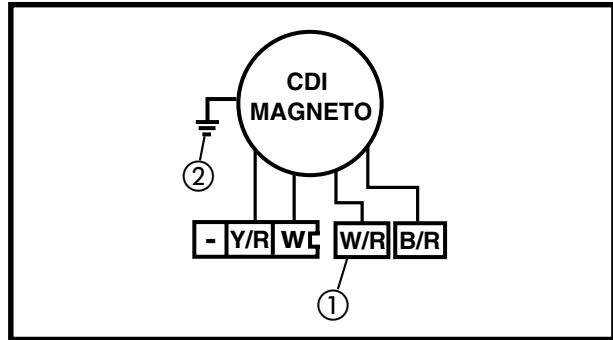

DOES NOT MEET SPECIFICATION



MEETS SPECIFICATION

6. Source coil resistance	
<ul style="list-style-type: none"> • Disconnect the source coil coupler from the wire harness. • Connect the pocket tester ($\Omega \times 100$) to the source coil. 	
Pocket tester (+) lead ① → Black / Red Pocket tester (-) lead ② → Ground	
<ul style="list-style-type: none"> • Check the source coil resistance. 	
	Source coil resistance : 640 ~ 960 Ω at 20°C (68°F)



Pickup coil defect → Replace.

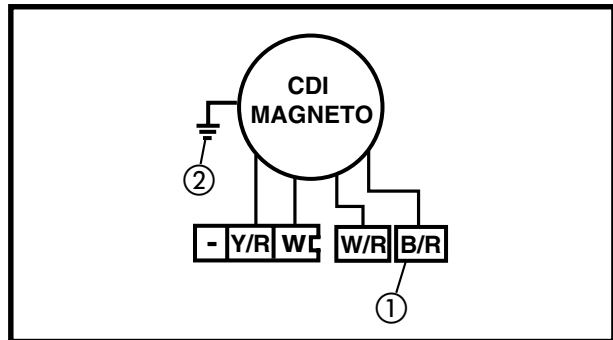

DOES NOT MEET SPECIFICATION



MEETS SPECIFICATION

7. Connections	
<ul style="list-style-type: none"> • Check all connections in the ignition system. Refer to "WIRING DIAGRAM". 	



Source coil defect → Replace.

POOR CONNECTIONS



GOOD CONNECTIONS



Repair.

Replace the CDI unit.

TROUBLESHOOTING

STARTER MOTOR DOES NOT WORK

NOTE :

- Remove the following parts before proceeding with the troubleshooting:
 - 1) Side covers (left and right)
 - 2) Footrest boards
 - 3) Front panel
 - 4) Handlebar cover
- For accurate troubleshooting use the following special tools:

Pocket tester :
90890-03112

1. Fuse

- Remove the fuse.
- Connect the pocket tester ($\Omega \times 1$) to the fuse.
- Check the fuse for continuity.

↓ CONTINUITY

NO CONTINUITY

↓

Defect → Replace fuse.

2. Battery

- Check the condition of the battery. Refer to "BATTERY INSPECTION" in CHAPTER 3.

↓ MEETS SPECIFICATION

DOES NOT MEET SPECIFICATION

↓

Open circuit voltage :
12.8 V or more at à 20°C (68°F)

- Clean battery terminals.
- Charge or replace the battery.

*** CAUTION:**

- If the gauge of the jumper lead is smaller than that of the battery leads, the jumper lead might melt or burn.
- This test could cause sparks. Never perform it near a gas source or near flammable products.

3. Starter motor

- Use a jumper lead ③ * to connect the (+) ① terminal of the battery to the starter motor terminal ②.

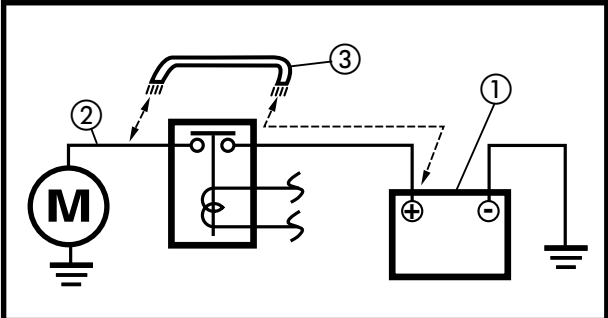

- Check the starter motor operation.

↓ WORKS

DOES NOT WORK

↓

Starter defect → Repair or replace.

4. Starter relay

- Disconnect the Blue/White lead from the wire harness.
- Connect the (-) ① terminal of the battery to the Blue/White lead.
- Check the starter motor operation.

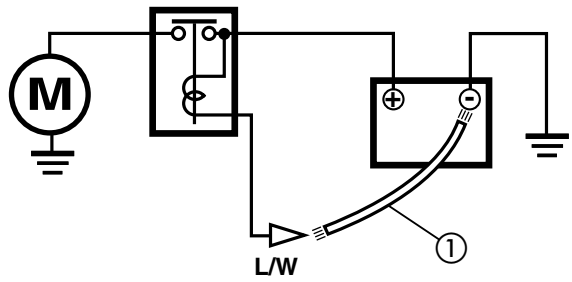

DOES NOT WORK

↓

Starter relay defect → Replace.

↓ WORKS

5. Main switch

- Disconnect the main switch from the wire harness.
- Check for continuity between Red ① and Brown ②.

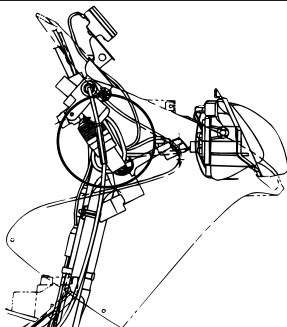

	BW	B	R	Br	Gy
LOCK	○	○			
OFF	○	○			
CHECK	○	○	○	○	
ON			○	○	

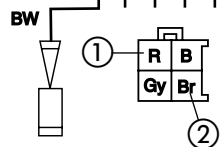

DOES NOT MEET SPECIFICATION

↓

Main switch defect → Replace.

↓ MEETS SPECIFICATION

6. Starter switch

- Disconnect the right handlebar switch coupler from the wire harness.
- Check for continuity between Blue / White ① and Black ②.

IGNITION AND STARTING SYSTEM

ELEC	
-------------	--

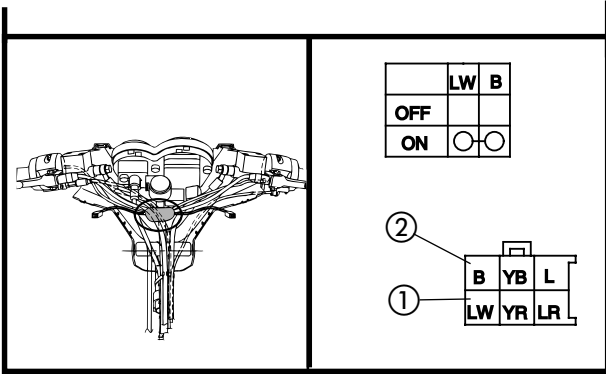

MEETS SPECIFICATION

7. Connections
Check all connections in the starter system.
Refer to "WIRING DIAGRAM".

DOES NOT MEET SPECIFICATION

Starter switch defect → Replace right handle-bar switch.

POOR CONNECTIONS

Repair.

TROUBLESHOOTING

THE BATTERY IS NOT CHARGED

NOTE : _____

- Remove the following parts before proceeding with the troubleshooting :
 - 1) Side covers (left and right) and foot rest board.
- For accurate troubleshooting use the following special tools :

Inductive tachometer :
90890-03113

Pocket tester :
90890-03112

1. Fuse (Main)

- Remove the fuse.
- Connect the pocket tester ($\Omega \times 1$) to the fuse.
- Check the fuse for continuity.

↓ CONTINUITY

2. Battery

- Check the condition of the battery.
Refer to "BATTERY INSPECTION" in CHAPTER 3.

Open circuit voltage :
12.8 V or more at 20°C (68°F)

↓

3. Charging voltage

- Connect the engine tachometer to the spark plug lead.
- Connect the pocket tester (DC20V) to the battery terminals.

Pocket tester (+) lead → Battery (+) terminal
Pocket tester (-) lead → Battery (-) terminal

- Start the engine and accelerate to about 5000 rpm.
- Check the charging voltage.

Charging voltage :
14 ~ 15 V at 5.000 tr/mn

NOTE: _____
Use a fully charged battery.

↓ OUT OF SPECIFICATION

NO CONTINUITY

↓

Fuse defect → Replace.

DOES NOT MEET SPECIFICATION

↓

- Clean battery terminals.
- Charge or replace the battery.

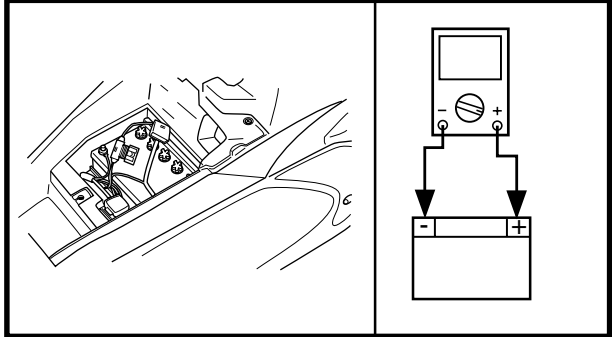

MEETS SPECIFICATION

↓

Charging circuit is OK.

4. Charging coil resistance
- Disconnect the CDI magneto coupler from the wire harness.
 - Connect the pocket tester ($\Omega \times 1$) to the charging coil.
 - Check the charging coil resistance

Tester (+) lead → White ①
Tester (-) lead → Ground ②

 **Charging coil resistance :**
0.48 ~ 0.72 Ω at 20°C (68°F)

↓ MEETS SPECIFICATION

5. Connections
Check all connections in the charging system.
Refer to "WIRING DIAGRAM".

↓ MEETS SPECIFICATION

Replace the rectifier/regulator.

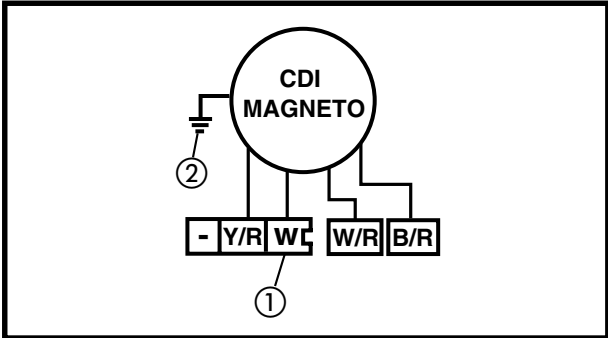

OUT OF SPECIFICATION

Charging coil defect → Replace.

POOR CONNECTIONS

Repair.

LIGHTING SYSTEM
CIRCUIT DIAGRAM

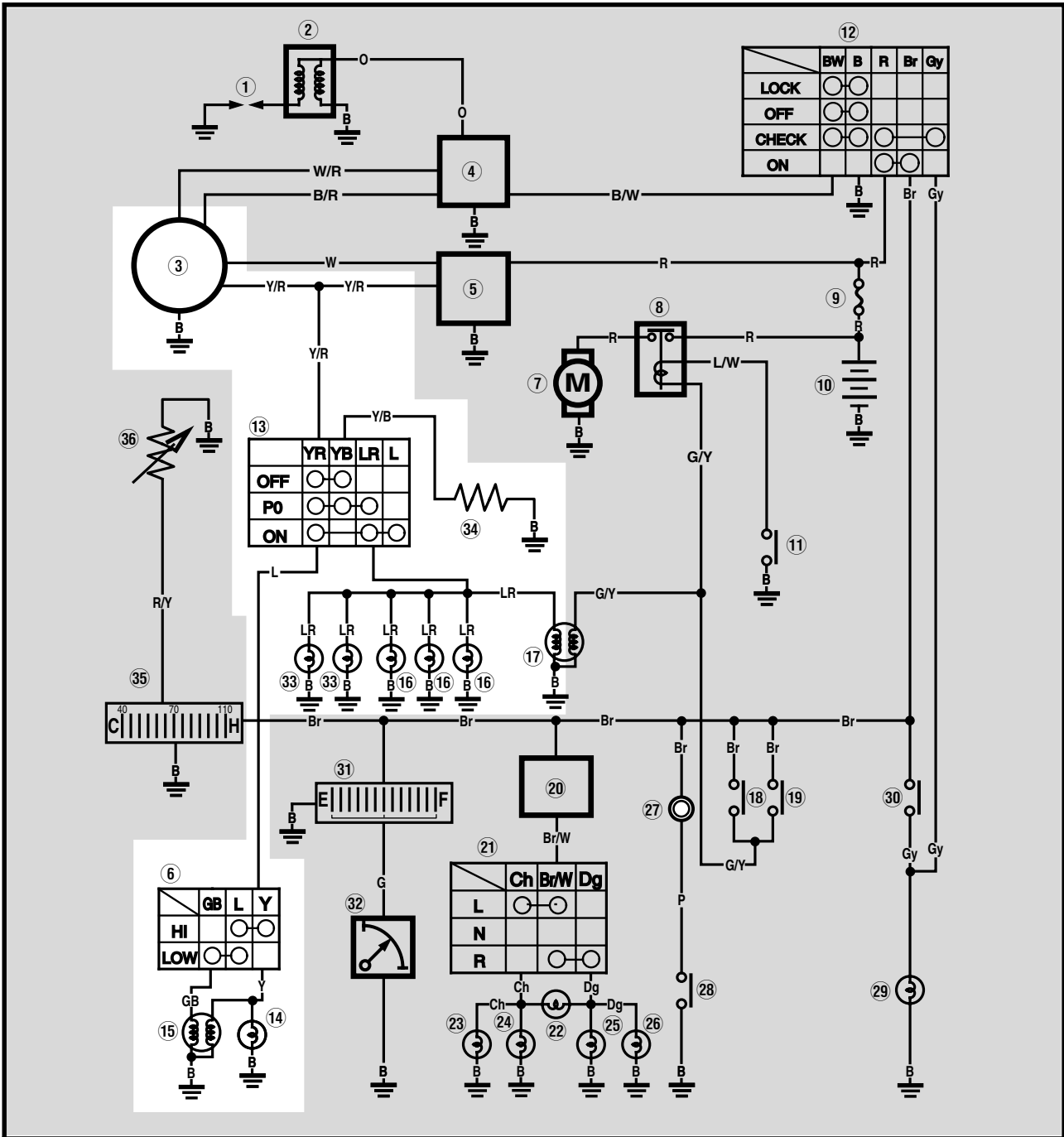

- ③ CDI magneto
- ⑥ Dimmer switch
- ⑬ Lighting switch
- ⑭ "HIGH BEAM indicator"
- ⑮ Head light
- ⑯ Meter light
- ⑰ Tail/Stop light
- ⑳ Position light
- ㉑ Resistor

TROUBLESHOOTING

THE AUXILIARY LIGHT, HEADLIGHT, HEADLIGHT INDICATOR, TAIL LIGHT OR METER LIGHT DO NOT WORK

NOTE :

Remove the following parts before proceeding with the troubleshooting :

- Side covers and footrest board
- Handlebar covers

For accurate troubleshooting use the following special tools :

 **Pocket tester :**
90890-03112

1. "LIGHTS" switch

- Disconnect the right handlebar switch coupler from the wire harness.
- Set the switch to "PO" (auxiliary light).
- Check for continuity between

Yellow / Red ① and Blue / Red ②

- Set the switch to "ON".
- Check for continuity between:

Yellow / Red ① and Blue / Red ②
Yellow / Red ① and Blue ③

 CONTINUITY

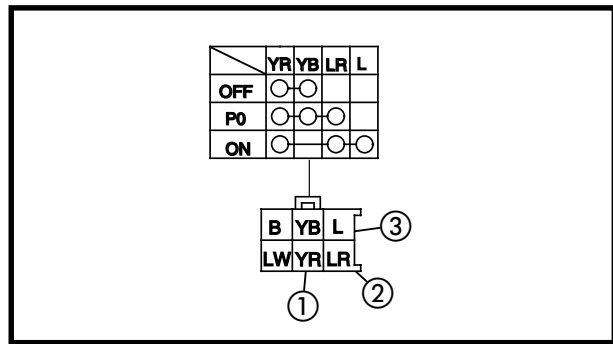

NO CONTINUITY

Right handlebar switch defect → Replace.

2. "HI/LO" switch

- Disconnect the "HI/LO" switch coupler (left) from the wire harness.
- Set the switch to "LO".
- Check for continuity between :

Blue ① and Green/Black ②

- Set the switch to "HI".
- Check for continuity between :

Blue ① and Yellow ③

 CONTINUITY

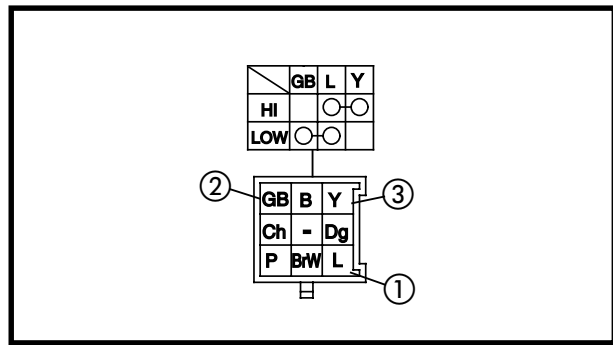

NO CONTINUITY



"HI/LO" switch defect → Replace.



3. Lighting coil resistance

- Disconnect the lighting coil coupler from the wire harness.
- Connect the pocket tester ($\Omega \times 1$) to the lighting coil.
- Check the lighting coil resistance

Tester (+) lead → Yellow / Red ①
Tester (-) lead → Ground ②

 **Lighting coil resistance :**
0.4 ~ 0.6 Ω (at 20°C (68°F)



MEETS SPECIFICATION

4. Connections

- Check all connections in the lighting system. Refer to "WIRING DIAGRAM".



MEETS SPECIFICATION

Circuit is in good condition.

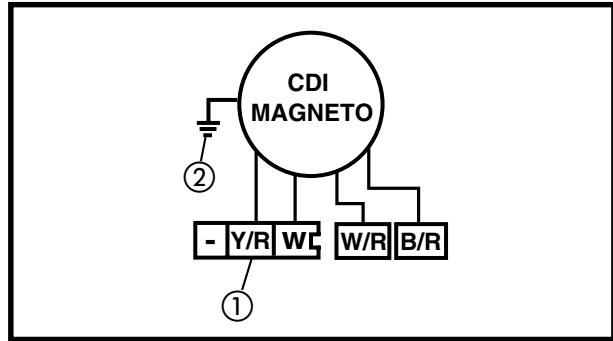

OUT OF SPECIFICATION



Lighting coil defect → Replace.

POOR CONNECTIONS



Repair.

LIGHTING SYSTEM INSPECTION

1. Headlight and headlight indicator do not work.

1. Bulb and socket
 • Check the bulb and socket for continuity.

↓ CONTINUITY

2. Voltage

• Connect the pocket tester (AC20V) to the headlight coupler.

Headlight :

• “LO”:
Pocket tester (+) lead → Green/Noir ①
Pocket tester (-) lead → Black ③

• “HI”:
Pocket tester (+) lead → Yellow ②
Pocket tester (-) lead → Black ③

• **Headlight indicator :**
Pocket tester (+) lead → Yellow ④
Pocket tester (-) lead → Black ⑤

• Set the main switch to “ON”.
 • Start the engine.
 • Switch from “HI” to “LO” and back.
 • Check the voltage (12V) between the headlight coupler leads.

↓ MEETS SPECIFICATION

Circuit is in good condition.

2. The meter light does not work.

1. Bulb and socket
 • Check the bulb and socket for continuity.

↓ CONTINUITY

NO CONTINUITY

Replace bulb or socket.

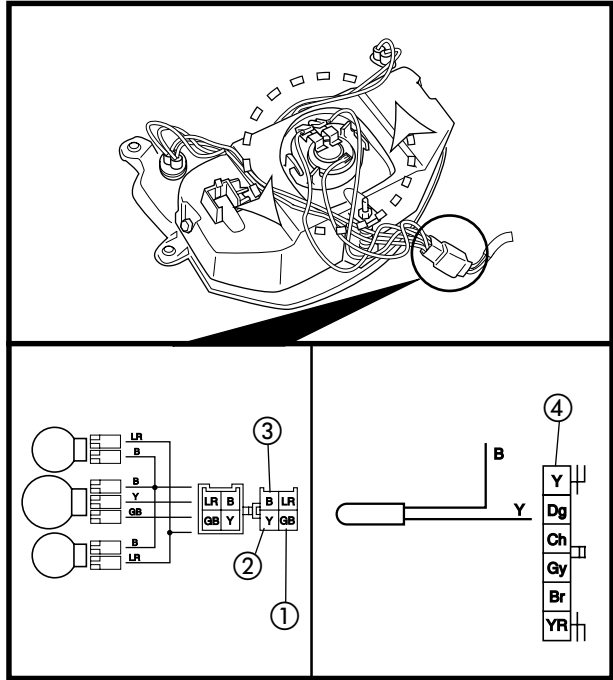

OUT OF SPECIFICATION

There is a defect in the wire harness between the main switch and the headlight coupler → Repair.

NO CONTINUITY

Replace bulb or socket.

LIGHTING SYSTEM

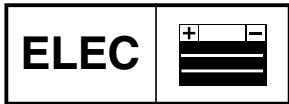

2. Voltage

- Connect the pocket tester (AC20V) to the meter light coupler.

Pocket tester (+) lead → Blue / Red ①
Pocket tester (-) lead → Black ②

- Set the main switch to “ON”.
- Start the engine.
- Check the voltage (12V) between the headlight coupler leads “Blue / Red” and “Black”.

MEETS SPECIFICATION

Circuit is in good condition.

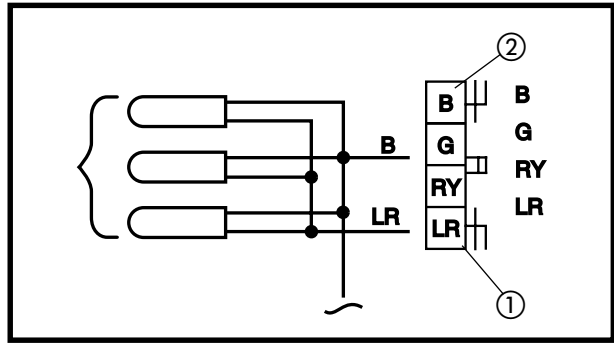

OUT OF SPECIFICATION

There is a defect in the wire harness between the main switch and the meter light coupler → Repair.

3. The tail light does not work.

1. Bulb and socket

- Check the bulb and socket for continuity.

CONTINUITY

NO CONTINUITY

Replace bulb or socket.

2. Voltage

- Connect the pocket tester (AC20V) to the taillight coupler.

Pocket tester (+) lead → Blue / Black ①
Pocket tester (-) lead → Black ②

- Set the main switch to “ON”.
- Start the engine.
- Check the voltage (12V) between the headlight coupler leads “Blue / Red” and “Black”.

MEETS SPECIFICATION

Circuit is in good condition.

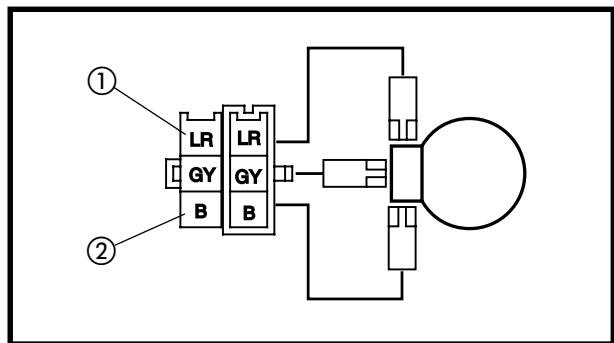

OUT OF SPECIFICATION

There is a defect in the wire harness between the main switch and the taillight coupler → Repair.

TROUBLESHOOTING

**FLASHER LIGHTS, TAIL/BRAKE LIGHT, "OIL" WARNING LIGHT DOES NOT WORK
HORN DOES NOT SOUND, FUEL METER DOES NOT WORK**

NOTE :

Remove the following parts before proceeding with the troubleshooting:

- Side covers and footrest board
- Handlebar cover

For accurate troubleshooting use the following special tools :



Pocket tester :
90890-03112

1. Fuse

- Remove the fuse.
- Connect the pocket tester ($\Omega \times 1$) to the fuse.
- Check the fuse for continuity.

Refer to "FUSE INSPECTION" in Chapter 3.



Fuse defect → Replace.



2. Battery

- Check the condition of the battery.

Refer to "BATTERY INSPECTION" in CHAPTER 3.



- Clean battery terminals.
- Charge or replace the battery.



Battery voltage :
12.8 V or more at 20°C (68°F)

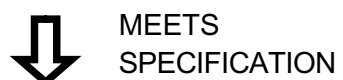

3. Main switch

- Disconnect the main switch from the wire harness.
- Turn the main switch to "∗".
- Check for continuity between :

Red ① and Gray ③

- Turn the main switch to "ON".
- Check for continuity between :

Red ① and Brown ②

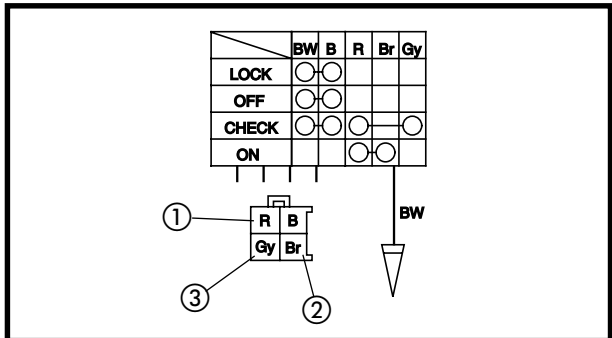

Main switch defect → Replace.





4. Connections

- Check all connections in the signal system. Refer to “WIRING DIAGRAM”.



GOOD CONNECTIONS

Check the condition of each circuit of the signal system. Refer to the section “SIGNAL SYSTEM CHECK”.

POOR CONNECTIONS

Repair.

SIGNAL SYSTEM CHECK

1. Horn does not sound

1. “HORN” switch

- Disconnect the handlebar switch (left) from the wire harness.
- Check for continuity between:

Black ① and Pink ②.

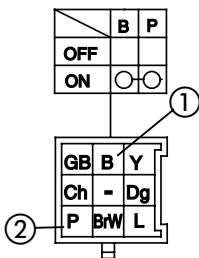

NO CONTINUITY

Horn switch is defect → Replace.



CONTINUITY

2. Voltage

- Connect the pocket tester (DC20V) to the horn lead.

Pocket tester (+) lead → Brown ①
Pocket tester (-) lead → Ground ②

- Turn the main switch to ON.
- Check for voltage (12V) between “Brown” and the ground.

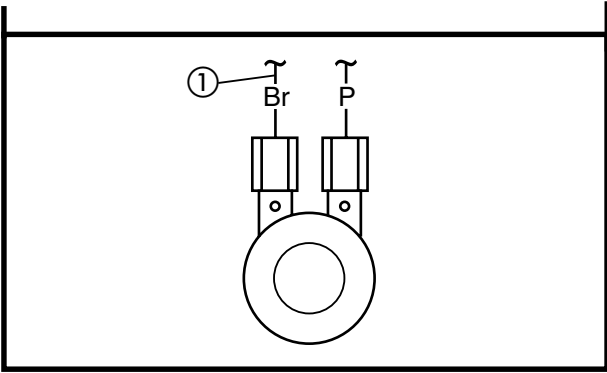

DOES NOT MEET SPECIFICATION

Defect in the wire harness between the main switch and the horn → Repair.

MEETS SPECIFICATION

3. Horn

- Disconnect the “Pink” lead at the horn terminal.
- Ground the horn terminal ① with a jumper lead.
- Set the main switch to ON.

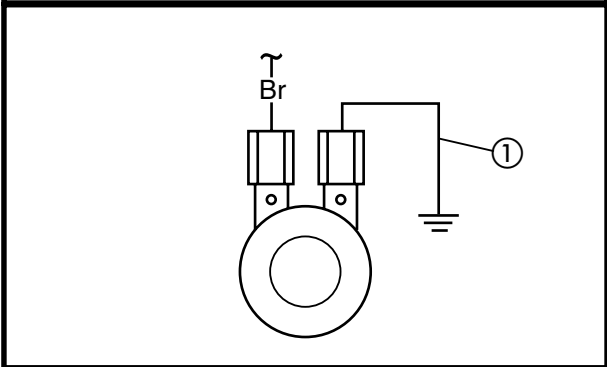

HORN SOUNDS

Horn in good condition.

HORN DOES NOT SOUND

4. Voltage

- Connect the pocket tester (DC20V) to the “Pink” lead.

Pocket tester (+) lead → Pink ①
Pocket tester (-) lead → Ground

- Turn the main switch to ON.
- Press the “HORN” switch.
- Check the voltage (12V) between “Pink” and ground.

DOES NOT MEET SPECIFICATION

Horn is defect → Replace.

MEETS SPECIFICATION

Adjust the horn.

2. The tail light does not work.

1. Bulb and socket
 • Check the bulb and socket for continuity.

↓ CONTINUITY

2. Brake switch
 • Disconnect the brake switch leads from the wire harness.
 • Check for continuity between:

Brown ① and Green / Yellow ②

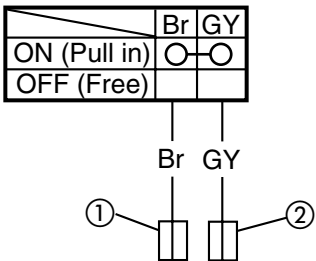

↓ CONTINUITY

3. Voltage
 • Connect the pocket tester (DC20V) to the socket.

Pocket tester (+) lead → Green / Yellow ①

Pocket tester (-) lead → Black ②

- Turn the main switch to “ON”.
- Pull the brake lever.
- Check the voltage (12V) between “Green / Yellow” ① and “Black” ②.

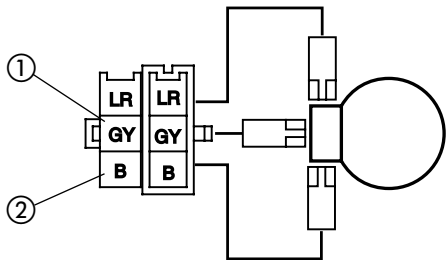

↓ MEETS SPECIFICATION

Circuit is in good condition.

NO CONTINUITY

Replace bulb or socket.

NO CONTINUITY

Brake switch is defect → Replace.

OUT OF SPECIFICATION

There is a defect in the wire harness between the main switch and the tail light socket → Repair.

3. Flasher does not work

1. Bulb and socket
 • Check the bulb and socket for continuity.

CONTINUITY

NO CONTINUITY

Replace bulb or socket.

2. "TURN" switch
 • Disconnect the handlebar switch (left) from the wire harness.
 • Check for continuity between :

Left side : Brown / White ① and Chocolate ②
 Right side : Brown / White ① and Dark green ③

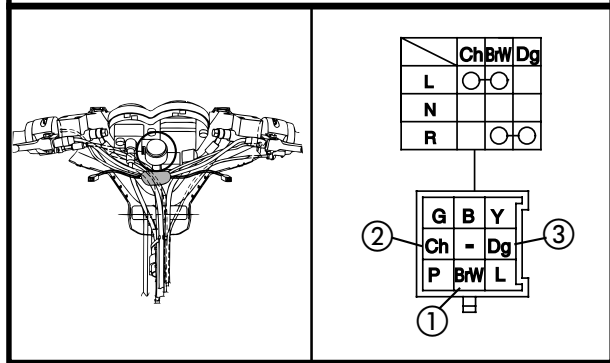

CONTINUITY

NO CONTINUITY

Left handlebar switch is defect → Replace.

3. Voltage
 • Connect the pocket tester (DC20V) to the flasher relay.

Pocket tester (+) lead → Brown ①
 Pocket tester (-) lead → Ground

• Turn the main switch to ON.
 • Check the voltage (12V) between the "Brown" lead and the ground.

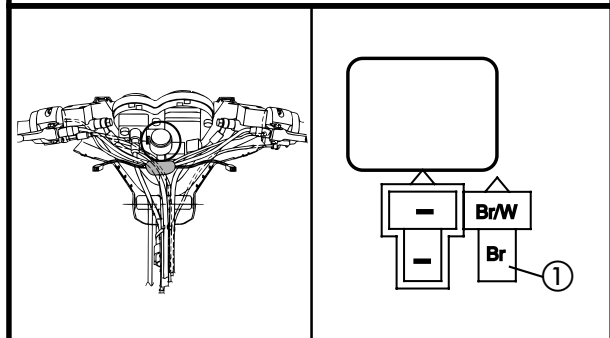

MEETS SPECIFICATION

DOES NOT MEET SPECIFICATION

Defect in the wire harness between the main switch and the flasher relay → Repair.

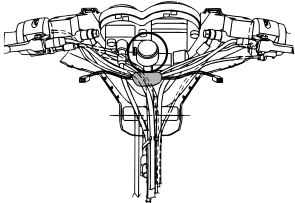
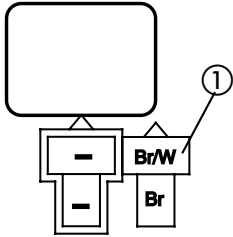

4. Voltage	
<ul style="list-style-type: none"> • Connect the pocket tester (DC20V) to the flasher relay. 	
Pocket tester (+) lead → Brown / White ① Pocket tester (-) lead → Ground	
<ul style="list-style-type: none"> • Turn the main switch to “ON”. • Check the voltage (12V) between Brown / White and the ground. 	
	



MEETS SPECIFICATION

DOES NOT MEET SPECIFICATION

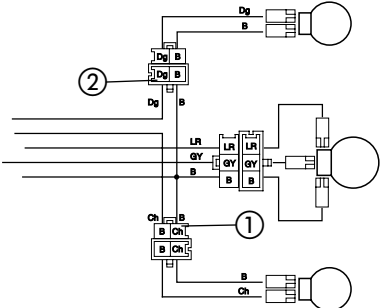

Flasher relay defect → Replace.

5. Voltage	
<ul style="list-style-type: none"> • Connect the pocket tester (DC20V) to the flasher connector. 	
Left flasher bulb : Pocket tester (+) lead → Chocolate ① Pocket tester (-) lead → Ground	
Right flasher bulb : Pocket tester (+) lead → Dark green ② Pocket tester (-) lead → Ground	
<ul style="list-style-type: none"> • Turn the main switch to “ON”. • Set the “TURN” switch to “L”, then to “R”. • Check the voltage (12V) between “Chocolate” and the ground, then “Dark green “ and the ground. 	
	



MEETS SPECIFICATION **8-27**

DOES NOT MEET SPECIFICATION



Defect in the wire harness between the main switch and the flasher bulb socket → Repair.
--



This circuit is in good condition.

4. The "OIL" indicator light does not work.

1. Bulb and socket
 • Check the bulb and socket for continuity.



Replace bulb or socket.



CONTINUITY

2. Oil level switch
 • Disconnect the oil level switch from the oil tank.
 • Connect the pocket tester ($\Omega \times 1$) to the oil level switch.

Pocket tester (+) lead → Terminal ①

Pocket tester (-) lead → Terminal ②

• Check the switch for continuity.

Float position	Good condition	Bad condition		
HIGH	X	O	X	O
LOW	O	X	X	O

O : Continuity X : No continuity

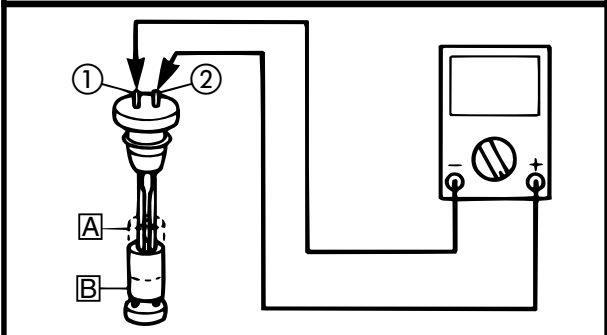

Replace oil level switch is defect.



MEETS SPECIFICATION





3. Voltage

- Connect the pocket tester (DC20V) to the bulb socket connector.

Pocket tester (+) lead → Grey ①
Pocket tester (-) lead → Ground

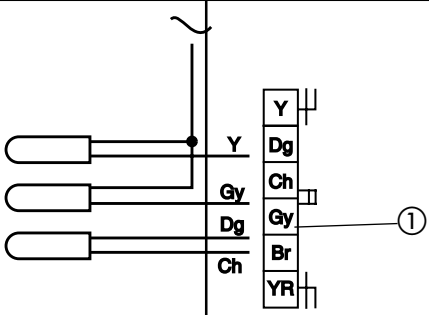
- Turn the main switch to ON.
- Check the voltage (12V) between “Grey” and the ground.



 MEET SPECIFICATION

This circuit is in good condition.

5.The fuel meter does not work.

1. Fuel sender unit

- Disconnect the fuel sender leads.
- Connect the pocket tester ($\Omega \times 100$) then ($\Omega \times 10$) to the fuel sender.
- Drain the fuel tank.
- Measure the resistance.

 **Sender unit resistance (empty tank):**
 90 ~ 100 Ω at 20°C (68°F)

- Fill the tank.
- Measure the resistance.

 **Sender unit resistance (full tank):**
 1.5 ~ 7.5 Ω at 20°C (68°F)

 MEET SPECIFICATION

This circuit is in good condition.

DOES NOT MEET SPECIFICATION



4. Connections

- Check all connections in the signal system. Refer to “WIRING DIAGRAM”.

DOES NOT MEET SPECIFICATION



Replace the fuel sender.

**COOLING SYSTEM
WIRING DIAGRAM**

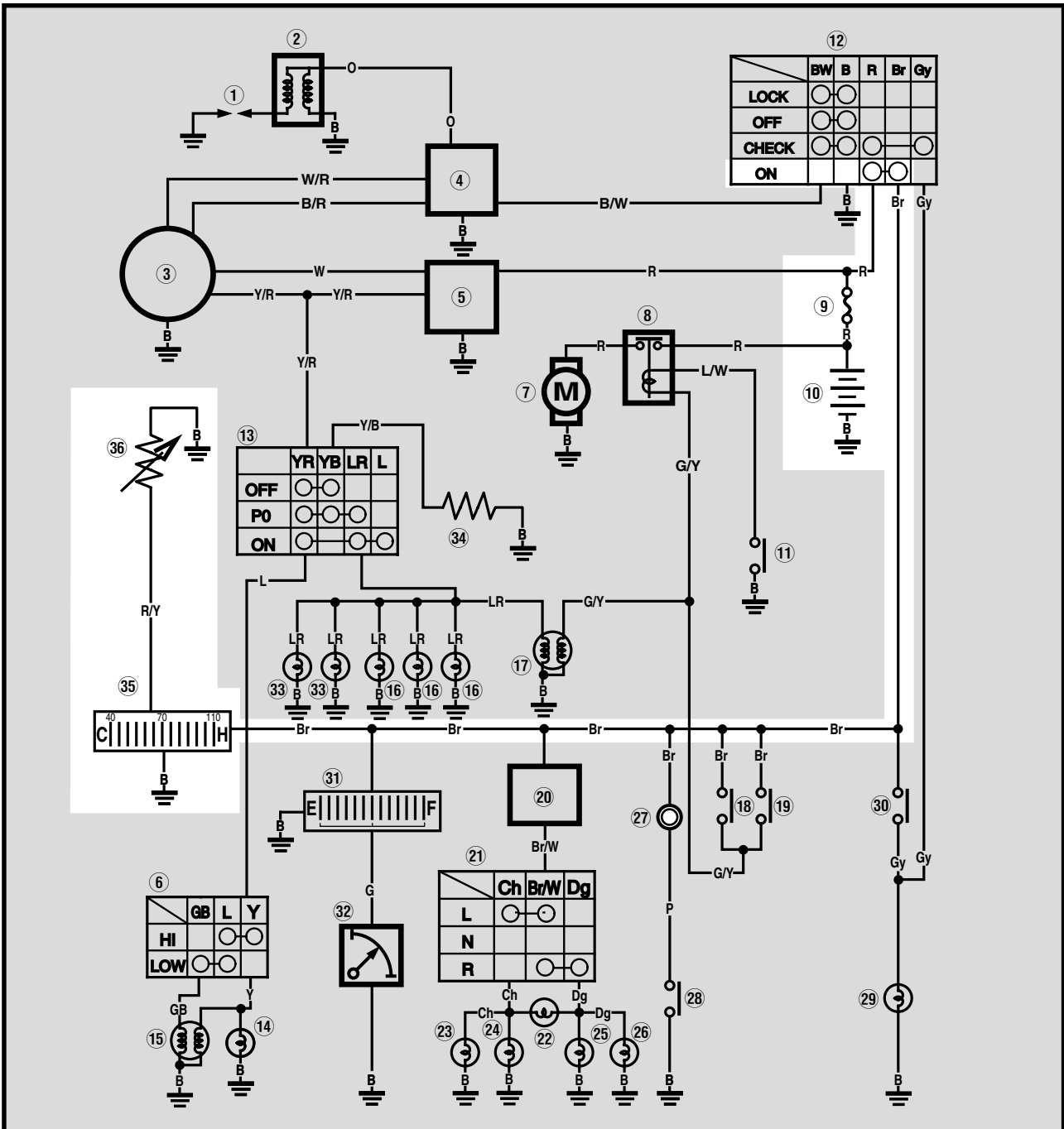

- ⑨ Fuse
- ⑩ Battery
- ⑫ Main switch
- ⑮ Water temperature indicator
- ⑯ Water sender

TROUBLESHOOTING

WATER TEMPERATURE METER DOES NOT MOVE, WHEN THE ENGINE IS WARM.

NOTE :

Remove the following parts before proceeding with the troubleshooting:

- Side covers and footrest board
- Handlebar cover

For accurate troubleshooting use the following special tools :

 **Pocket tester :**
90890-03112

1. Fuse

- Remove the fuse.
- Connect the pocket tester ($\Omega \times 1$) to the fuse.
- Check the fuse for continuity.

Refer to "FUSE INSPECTION" in Chapter 3.

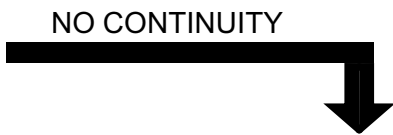

Fuse defect → Replace.



2. Battery

- Check the condition of the battery.

Refer to "BATTERY INSPECTION" in CHAPTER 3.

 **Battery voltage :**
12.8 V or more at 20°C (68°F)



- Clean battery terminals.
- Charge or replace the battery.

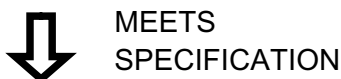

3. Main switch

- Disconnect the main switch from the wire harness.
- Turn the main switch to "∗".
- Check for continuity between :

Red ① and Gray ③

- Turn the main switch to "ON".
- Check for continuity between :

Red ① and Brown ②

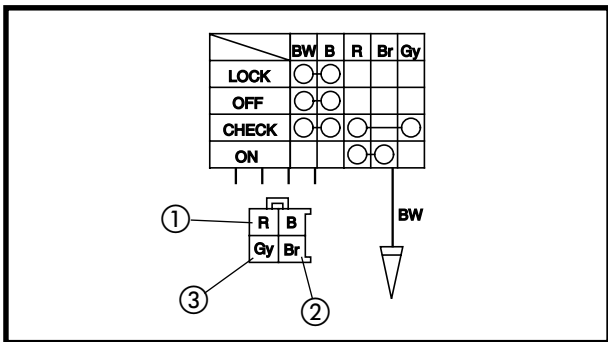

Main switch defect → Replace.

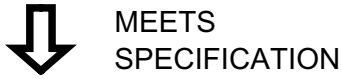



4. Thermo unit

- Remove the thermo unit from the head cylinder.
- Connect the pocket tester ($\Omega \times 100$) then ($\Omega \times 10$) to the thermo unit ①.
- Immerse the thermo unit in the water.
- Measure the resistance.

 **Thermo unit resistance:**
 25°C: 504 ~ 614 Ω
 100°C: 37.8 ~ 41.6 Ω

⚠ WARNING

- Handle the thermo unit with special care.
- Never subject it to strong shock or allow it to be dropped. Should it be dropped, it must be replaced.

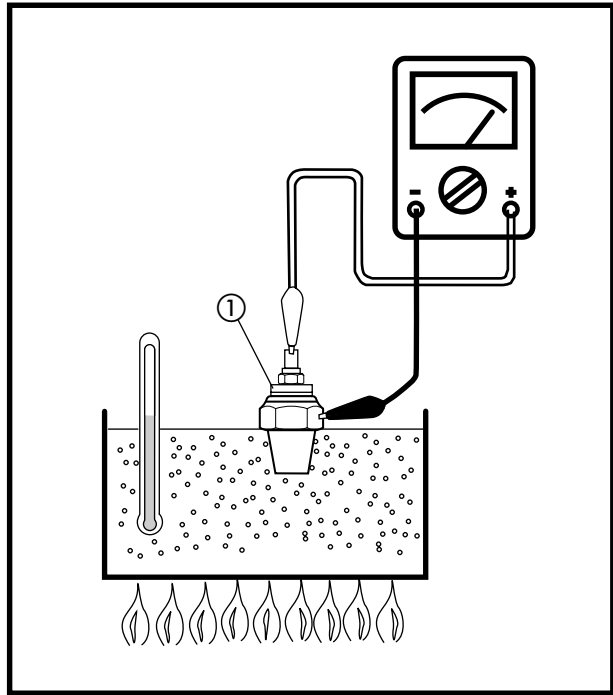

DOES NOT MEET SPECIFICATION



Replace the thermo unit.



MEETS SPECIFICATION

7. Wiring connection

Check the entire cooling system for connections. Refer to "CIRCUIT DIAGRAM".

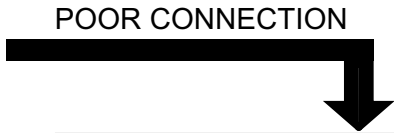

Correct.



Replace the meter unit complete.

?

**TRBL
SHTG**

9

CHAPTER 9. TROUBLESHOOTING

STARTING FAILURE/ HARD STARTING	9-1
FUEL SYSTEM	9-1
ELECTRICAL SYSTEM	9-1
COMPRESSION SYSTEM	9-2
POOR IDLE SPEED PERFORMANCE	9-2
POOR IDLE SPEED PERFORMANCE	9-2
POOR MEDIUM AND HIGH SPEED PERFORMANCE	9-3
FUEL SYSTEM	9-3
ELECTRICAL SYSTEM	9-3
COMPRESSION SYSTEM	9-3
FAULTY AUTOMATIC (V-BELT TYPE)	9-3
SCOOTER DOES NOT MOVE WHILE ENGINE IS OPERATING	9-3
CLUTCH -OUT FAILURE	9-3
POOR STANDING START (LOW CLIMBING ABILITY)	9-4
POOR ACCELERATION (POOR HIGH SPEED)	9-4
OVER HEATING OR OVER COOLING	9-4
OVER HEATING	9-4
OVER COOLING	9-4
IMPROPER KICKING	9-5
SLIPPING	9-5
HARD KICKING	9-5
KICK CRANK NOT RETURNING	9-5
FAULTY BRAKE	9-5
POOR BRAKING EFFECT	9-5
INSTABLE HANDLING	9-6
INSTABLE HANDLING	9-6
FAULTY SIGNAL AND LIGHTING SYSTEM	9-7
WIRING DIAGRAM	

TROUBLESHOOTING**NOTE:**

The following troubleshooting does not cover all the possible causes of trouble. It should be helpful, however, as a guide to troubleshooting. Refer to the relative procedure in this manual for inspection, adjustment and replacement of parts.

STARTING FAILURE/HARD STARTING**FUEL SYSTEM****Fuel tank**

- Empty
- Clogged fuel filter
- Deteriorated fuel or fuel containing water or foreign material
- Clogged fuel tank cap

Fuel cock

- Clogged fuel hose

Air cleaner

- Clogged air filter

Carburetor

- Deteriorated fuel, fuel containing water or foreign material
- Clogged pilot jet
- Clogged pilot air passage
- Sucked-in air
- Deformed float
- Groove-worm needle valve
- Improperly sealed valve seat
- Improperly adjusted fuel level
- Improperly set pilot jet
- Clogged starter jet
- Starter plunger malfunction
- Improperly adjusted pilot air screw

ELECTRICAL SYSTEM**Spark plug**

- Improper plug gap
- Worm electrodes
- Wire between terminals broken
- Improper heat range
- Faulty spark plug cap

Ignition coil

- Broken or shorted primary/secondary
- Faulty spark plug lead
- Broken body

CDI unit system

- Faulty CDI unit
- Faulty source coil
- Faulty pick-up coil

Switches and wiring

- Faulty main switch
- Broken or shorted wiring

STARTING FAILURE/HARD STARTING/ POOR IDLE SPEED PERFORMANCE

TRBL
SHTG

?

COMPRESSION SYSTEM

Cylinder and cylinder head

- Loose spark plug
- Loose cylinder head or cylinder
- Broken cylinder head gasket
- Broken cylinder gasket
- Worn, damaged or seized cylinder

Piston and piston rings

- Improperly installed piston ring
- Worn, fatigued or broken piston ring
- Seized piston ring
- Seized or damaged piston

Crankcase and crankshaft

- Improperly seated crankcase
- Improperly sealed crankcase (damaged oil seal)
- Seized crankshaft

Reed valve

- Deformed reed valve stopper
- Improperly seated reed valve
- Loose intake manifold
- Broken gasket
- Broken reed valve

POOR IDLE SPEED PERFORMANCE

POOR IDLE SPEED PERFORMANCE

Carburetor

- Improperly returned starter plunger
- Clogged or loose pilot jet
- Clogged pilot air jet
- Improperly adjusted idle speed (throttle stop screw)
- Improper throttle cable play
- Flooded carburetor

POOR MEDIUM AND HIGH SPEED PERFORMANCE

FUEL SYSTEM

Fuel tank

- Clogged fuel filter
- Deteriorated fuel or fuel containing water or foreign material
- Clogged fuel tank cap

Fuel cock

- Clogged fuel hose

Air cleaner

- Clogged air cleaner

Carburetor

- Deteriorated fuel, fuel containing water or foreign material
- Sucked-in air
- Deformed float
- Groove-worm needle valve
- Improperly sealed valve seat
- Improperly set clip position of jet needle
- Improperly adjusted fuel level
- Clogged or loose main jet
- Clogged or loose main nozzle

ELECTRICAL SYSTEM

Spark plug

- Improper plug gap
- Worm electrodes
- Wire between terminals broken
- Improper heat range
- Faulty spark plug cap

CDI unit system

- Faulty CDI unit
- Faulty source coil
- Faulty pick-up coil

COMPRESSION SYSTEM

Cylinder and cylinder head

- Loose spark plug
- Loose cylinder head or cylinder
- Broken cylinder head gasket
- Broken cylinder gasket
- Worn, damaged or seized cylinder

Piston and piston rings

- Improperly installed piston ring
- Worn, fatigued or broken piston ring
- Seized piston ring
- Seized or damaged piston

Crankcase and crankshaft

- Improperly seated crankcase
- Improperly sealed crankcase (damaged oil seal)
- Seized crankshaft

Reed valve

- Deformed reed valve stopper
- Improperly seated reed valve
- Loose intake manifold
- Broken gasket
- Broken reed valve

FAULTY AUTOMATIC (V-BELT TYPE)

SCOOTER DOES NOT MOVE WHILE ENGINE IS OPERATING.

V-belt

- Worn, damaged or slipped v-belt

Primary sheave

- Worn or damaged cam plate
- Worn or damaged slider bushing

Secondary sheave

- Broken compression spring
- Pealed lining from clutch shoe
- Worn spline of clutch housing

CLUTCH-OUT FAILURE

Primary sheave

- Seized primary sliding sheave and collar

Secondary sheave

- Broken or fatigued clutch shoe spring

FAULTY AUTOMATIC/ OVER HEATING OR OVER-COOLING



POOR STANDING START (LOW CLIMBING ABILITY)

V-belt

- Worn, damaged or slipped v-belt

Primary sheave

- Worn or improper operation of weight

Secondary sheave

- Fatigued compression spring
- Improper operation of secondary sliding sheave

POOR ACCELERATION (POOR HIGH SPEED)

V-belt

- Worn or greasy V-belt

Secondary sheave

- Worn or greasy clutch shoe
- Improper operation of secondary sliding sheave

OVER HEATING OR OVER-COOLING

OVER HEATING

Ignition system

- Improper spark plug gap
- Improper spark plug head range
- Faulty ignitor unit

Fuel system

- Improper carburetor setting
- Improper fuel level adjustment
- Clogged air cleaner element

Compression system

- Heavy carbon deposit build-up

Engine oil

- Improper engine oil quality (high viscosity)
- Low engine oil quality

Brakes

- Dragging brake

Cooling system

- Faulty thermostat
- Faulty thermo switch
- Incorrect coolant level (low coolant level)
- Faulty radiator (Clogged, Damage)
- Impeller shaft gear malfunction (bent dowel pin, gear)
- Damaged impeller shaft

OVER-COOLING

Cooling system

- Faulty thermostat
- Faulty thermo switch

IMPROPER KICKING

SLIPPING

Kick axle assembly

- Low tension of kick clip
- Worn kick axle
- Worn or damaged kick gear
- Damaged kick clip
- Kick clip coming off
- Damaged kick clip stopper

Transmission oil

- Improper quality (low viscosity)
- Deterioration

HARD KICKING

Kick axle assembly

- High tension of kick clip
- Seized kick gear

Crankcase and crankshaft

- Improperly seated crankcase
- Improperly seated crankshaft
- Damaged or seized crankshaft
- Damaged or seized crankshaft bearing

Cylinder, piston and piston ring

- Damaged or seized cylinder
- Damaged or seized piston
- Damaged or seized piston ring

KICK CRANK NOT RETURNING

Kick axle assembly

- Damaged kick return spring
- Kick return spring coming off
- Kick clip coming off
- Damaged kick return spring stopper

FAULTY BRAKE

POOR BRAKING EFFECT

Disc brake

- Worn brake pads
- Worn disc
- Air in brake fluid
- Leaking brake fluid
- Faulty cylinder cup kit
- Faulty caliper seal kit
- Loose union bolt
- Broken brake hose
- Oily or greasy disc/brake pads
- Improper brake fluid level

FRONT FORK OIL LEAKAGE AND FRONT FORK MALFUNCTION/ INSTABLE HANDLING

TRBL
SHTG

?

FRONT FORK OIL LEAKAGE AND FRONT FORK MALFUNCTION

OIL LEAKAGE

- Bent, damaged or rusty inner tube
- Damaged or cracked outer tube
- Damaged oil seal lip
- Improper installed oil seal
- Improper oil level (too much)
- Loose damper rod holding bolt
- Broken cap bolt O-ring

MALFUNCTION

- Bent, deformed or damaged inner tube
- Bent or deformed outer tube
- Damaged fork spring
- Worn or damaged slide metal
- Bent or damaged damper rod
- Improper oil viscosity
- Improper oil level

INSTABLE HANDLING

INSTABLE HANDLING

Handlebar

- Improperly installed or bent

Steering

- Improperly installed steering column
(Improperly tightened ring nut)
- Bent steering column
- Damaged ball bearing or bearing race

Front forks

- Broken spring
- Bended front forks

Tires

- Uneven tire pressures on both sides
- Incorrect tire pressure
- Unevenly worn tires

Wheels

- Damaged bearing
- Bent or loose wheel axle
- Excessive wheel run-out

Frame

- Twisted
- Damaged head pipe
- Improperly installed bearing race

Engine bracket

- Bent or damaged

Rear shock absorber

- Fatigued spring
- Oil leakage

FAULTY SIGNAL AND LIGHTING SYSTEM

Headlight dark

- Improper bulb
- Too many electric accessories
- Hard charging (broken charging coil)
- Incorrect connection
- Improperly grounded
- Poor contacts (main or light switch)
- Bulb life expires

Bulb burnt out

- Improper bulb
- Improperly grounded
- Faulty main and/or light switch
- Bulb life expires
- Bulb burnt out

Flasher winks slower

- Faulty flasher relay
- Insufficient battery capacity (nearly discharged)
- Improper bulb
- Faulty main and/or flasher switch

Flasher winks quicker

- Improper bulb
- Faulty flasher relay

Flasher does not light

- Improperly grounded
- Discharged battery
- Faulty flasher switch
- Faulty flasher relay
- Broken wireharness
- Loosely connected coupler
- Bulb burnt out
- Faulty fuse

Flasher keeps on

- Faulty flasher relay
- Insufficient battery capacity (nearly discharged)

Horn is inoperative

- Faulty battery
- Faulty fuse
- Faulty main and/or horn switch
- Improperly adjusted horn
- Faulty horn
- Broken wireharness

YQ50 WIRING DIAGRAM

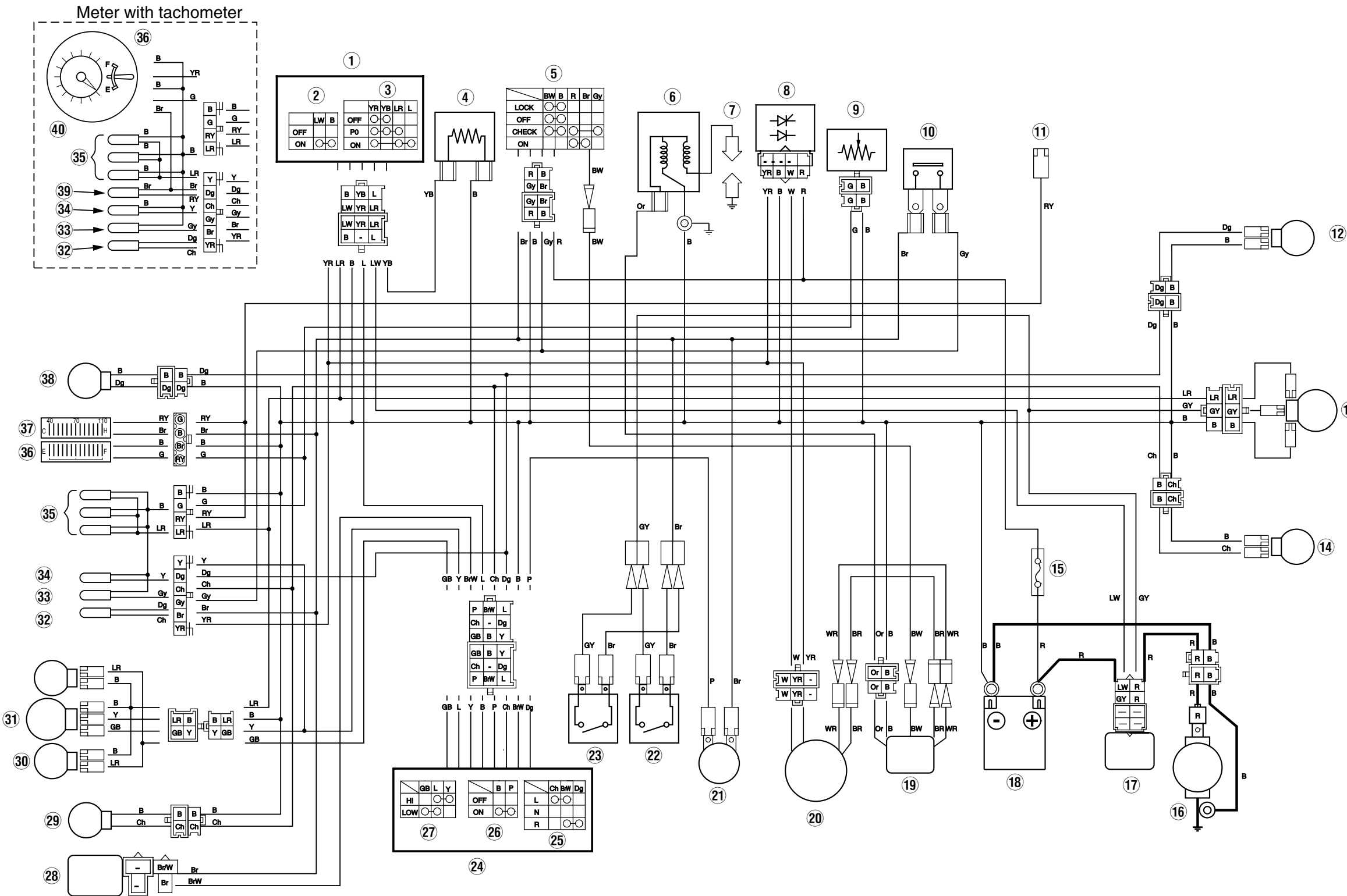

- ① Handlebar switch (right)
- ② "START" switch
- ③ "LIGHT" switch
- ④ Resistor
- ⑤ Main switch
- ⑥ Ignition coil
- ⑦ Spark plug
- ⑧ Rectifier / regulator
- ⑨ Fuel lever sender
- ⑩ Oil lever switch
- ⑪ Water temp. sender
- ⑫ Rear flasher (right)
- ⑬ Tail / brake light
- ⑭ Rear flasher (left)
- ⑮ Fuse
- ⑯ Starter motor
- ⑰ Starter relay
- ⑱ Battery
- ⑲ CDI unit
- ⑳ CDI magneto
- ㉑ Horn
- ㉒ Rear brake switch
- ㉓ Front brake switch (left)
- ㉔ "TURN" switch
- ㉕ "HORN" switch
- ㉖ "HI / LO" switch
- ㉗ Flasher relay
- ㉘ Front flasher (left)
- ㉙ Auxiliary light
- ㉚ Head light
- ㉛ "TURN" indicator light
- ㉜ "OIL" warning light
- ㉝ "HIGH BEAM" indicator light
- ㉞ Meter light
- ㉟ Fuel meter
- ㊱ Water temperature gauge
- ㊲ Front flasher light (right)
- ㊳ Water temp. warning light
- ㊴ Tachometer

COLOR CODE

B	Black	O	Orange	B/R	Black/Red	Br/Y	Brown/Yellow
L	Blue	Br	Brown	B/W	Black/White	Br/W	Brown/White
G	Green	Gy	Grey	L/W	Blue/White	W/R	White/Red
Y	Yellow	Ch	Chocolate	G/Y	Green/Yellow	R/Y	Red/Yellow
R	Red	Dg	Dark green	Y/B	Yellow/Black		
P	Pink	W	White	Y/R	Yellow/Red		